

AxN

CONFIGURABLE MOTION

CONTROL PLATFORM

User Manual

Support Model:

AxN 09.20.4

Version: 1.8

Summary

1	SAFETY INSTRUCTIONS (READ FIRST!)	2
1.1	Important Directions for Use	3
1.2	Safety Instructions for Electric Drives and Controls	4
1.3	Instructions with regard to Specific Dangers	6
2	TECHNICAL SPECIFICATIONS	11
2.1	Specifications	12
2.2	Ambient Conditions	14
3	MECHANICAL INSTALLATION	16
3.1	Notes for Operation	17
3.2	Installation Environment	17
3.3	Overall Dimensions	18
3.4	Installation Orientation and Spacing	19
4	ELECTRICAL INSTALLATION	21
4.1	Standard Connection Diagram	22
4.2	Main Circuit	23
4.2.1	Main Circuit Connection Diagram	23
4.2.2	Power Supply Input Port (P1)	24
4.2.3	AC Power Supply Input	25
4.2.4	DC Power Supply Input	26
4.2.5	Brake Resistor	28
4.2.6	Motor Power Output Port (P2)	30
4.2.7	Motor Power Output	31
4.3	Control Circuit	33
4.3.1	Auxiliary Power Supply (AUX Power)	33
4.3.2	Safe Torque Off (STO)	34
4.3.3	System Relay (R1)	35
4.4	Communication Port	37
4.4.1	Overview of Communication Port Panel	37
4.4.2	E1 Connector—Main Encoder Port	38
4.4.3	Sincos Encoder	39
4.4.4	Endat Encoder	40
4.4.5	Digital Incremental Encoder with Hall	41
4.4.6	Resolver	42
4.4.7	Hiperface Encoder	43
4.4.8	S1 Connector—Serial Bus Port	44
4.4.9	RS-232	44
4.4.10	RS-422/RS-485	47
4.4.11	Auxiliary CAN	48
4.4.12	C1 Connector—Main CAN Port	50
4.4.13	Main CAN	50
4.4.14	Auxiliary Encoder	52
4.4.15	EtherCAT IN/OUT—EtherCAT Port	53
4.4.16	U1/U2—User Connectors	54
5	APPENDIX: ACCESSORIES	56
5.1	Prefabricated Motor Power Output Cable	57
5.2	Prefabricated Encoder Cable (for Phase Motors)	58
5.3	Cable Support	59

1 SAFETY INSTRUCTIONS (READ FIRST!)

1.1 Important Directions for Use

Appropriate Use

Introduction

PMC products represent state-of-the-art developments and manufacturing. They are tested prior to delivery to ensure operating safety and reliability.

The products may only be used in the manner that is defined as appropriate. If they are used in an inappropriate manner, then situations can develop that may lead to property damage or injury to personnel.

Note: PMC as manufacturer is not liable for any damages resulting from inappropriate use. In such cases, the guarantee and the right to payment of damages resulting from inappropriate use are forfeited. The user alone carries all responsibility of the risks.

Before using PMC products, make sure that all the pre-requisites for an appropriate use of the products are satisfied:

- » Personnel that in any way, shape or form uses our products must first read and understand the relevant safety instructions and be familiar with appropriate use.
- » If the products take the form of hardware, then they must remain in their original state, in other words, no structural changes are permitted. It is not permitted to decompile software products or alter source codes.
- » Do not mount damaged or faulty products or use them in operation.
- » Make sure that the products have been installed in the manner described in the relevant documentation.

Areas of Use and Application

Drive controllers made by PMC are designed to control electrical motors and monitor their operation. Control and monitoring of the motors may require additional sensors and actors.

Note: The drive controllers may only be used with the accessories and parts specified in this document. If a component has not been specifically named, then it may not be either mounted or connected. The same applies to cables and lines. Operation is only permitted in the specified configurations and combinations of components using the software and firmware as specified.

Every drive controller has to be programmed before commissioning, making it possible for the motor to execute the specific functions of an application. The drive controllers have been developed for use in single- and multi-axis drive and control tasks.

To ensure an application-specific use, the drive controllers are available with different drive power and different interfaces.

Typical applications of the drive controllers include:

- » handling and mounting systems;

- » packaging and food machines;
- » printing and paper processing machines;
- » machine tools.

The drive controllers may only be operated under the assembly and installation conditions described in this documentation, in the specified position of normal use and under the ambient conditions as described (temperature, degree of protection, humidity, EMC, etc.).

Inappropriate Use

Using the drive controllers outside of the operating conditions described in this documentation and outside of the indicated technical data and specifications is defined as “inappropriate use”.

Drive controllers must not be used, if

- » ... they are subject to operating conditions that do not meet the specified ambient conditions. This includes, for example, operation under water, under extreme temperature fluctuations or extremely high maximum temperatures.
- » Furthermore, the drive controllers must not be used in applications which have not been expressly authorized by PMC.
- » Please carefully follow the specifications outlined in the general Safety Instructions!

1.2 Safety Instructions for Electric Drives and Controls

General Information

Using the Safety Instructions and Passing them on to Others

Do not attempt to install or commission this device without first reading all documentation provided with the product. Read and understand these safety instructions and all user documentation prior to working with the device. If you do not have the user documentation for the device, contact your responsible PMC sales representative. Ask for these documents to be sent immediately to the person or persons responsible for the safe operation of the device. If the device is resold, rented and/or passed on to others in any other form, then these safety instructions must be delivered with the device.

Improper use of these devices, failure to follow the safety instructions in this document or tampering with the product, including disabling of safety devices, may result in material damage, bodily harm, electric shock or even death!



Instructions for Use

Read these instructions before the initial startup of the equipment in order to eliminate the risk of bodily harm or material damage. Follow these safety instructions at all times.

- » PMC is not liable for damages resulting from failure to observe the warnings provided in this documentation.
- » Read the operating, maintenance and safety instructions in your language before starting up the machine. If you find that you cannot completely understand the documentation for your product, please ask your supplier to clarify.



- » Proper and correct transport, storage, assembly and installation as well as care in operation and maintenance are prerequisites for optimal and safe operation of this device.
- » Only assign trained and qualified persons to work with electrical installations:
 Only persons who are trained and qualified for the use and operation of the device may work on this device or within its proximity. The persons are qualified if they have sufficient knowledge of the assembly, installation and operation of the equipment as well as an understanding of all warnings and precautionary measures noted in these instructions. Furthermore, they must be trained, instructed and qualified to switch electrical circuits and devices on and off in accordance with technical safety regulations, to ground them and to mark them according to the requirements of safe work practices. They must have adequate safety equipment and be trained in first aid.
- » Only use spare parts and accessories approved by the manufacturer.
- » Follow all safety regulations and requirements for the specific application as practiced in the country of use.

For machine and installation manufacturers:

- » The devices have been designed for installation in industrial machinery.
- » The ambient conditions given in the product documentation must be observed.
- » The information given in the documentation of the product with regard to the use of the delivered components contains only examples of applications and suggestions.
 The machine and installation manufacturer must make sure that the delivered components are suited for his individual application and check the information given in this documentation with regard to the use of the components, make sure that his application complies with the applicable safety regulations and standards and carry out the required measures, modifications and complements.
- » Startup of the delivered components is only permitted once it is sure that the machine or installation in which they are installed complies with the national regulations, safety specifications and standards of the application.
- » Operation is only permitted if the national EMC regulations for the application are met.
- » The machine or installation manufacturer is responsible for compliance with the limiting values as prescribed in the national regulations.
- » Technical data, connections and operational conditions are specified in the product documentation and must be followed at all times.

Explanation of Warning Symbols and Degrees of Hazard Seriousness

The safety instructions describe the following degrees of hazard seriousness. The degree of hazard seriousness informs about the consequences resulting from non-compliance with the safety instructions:

Warning symbol with signal word	Degree of hazard seriousness according to ANSI Z 535
	Death or severe bodily harm will occur.
	Death or severe bodily harm may occur.



Bodily harm or material damage may occur.

Hazards by Improper Use

	<p>High electric voltage and high working current! Risk of death or severe bodily injury by electric shock!</p>
	<p>Dangerous movements! Danger to life, severe bodily harm or material damage by unintentional motor movements!</p>
	<p>High electric voltage because of incorrect connection! Risk of death or bodily injury by electric shock!</p>
	<p>Health hazard for persons with heart pacemakers, metal implants and hearing aids in proximity to electrical equipment!</p>
	<p>Hot surfaces on device housing! Danger of injury! Danger of burns!</p>
	<p>Electrical hazard due to water leakage on electrical component. Risk of injury by improper handling! Risk of bodily injury by bruising, shearing, cutting, hitting, or improper handling of pressurized lines!</p>

1.3 Instructions with regard to Specific Dangers

Protection against Contact with Electrical Parts

Note: This section only concerns devices and drive components with voltages of more than 50 Volt.

Contact with parts conducting voltages above 50 Volts can cause personal danger and electric shock. When operating electrical equipment, it is unavoidable that some parts of the devices conduct dangerous voltage.

High electrical voltage! Danger to life, electric shock and severe bodily injury!



- » Only those trained and qualified to work with or on electrical equipment are permitted to operate, maintain and repair this equipment.
- » Follow general construction and safety regulations when working on electrical power installations.

- » Before switching on the device, the equipment grounding conductor must have been no detachably connected to all electrical equipment in accordance with the connection diagram.
- » Do not operate electrical equipment at any time, even for brief measurements or tests, if the equipment grounding conductor is not permanently connected to the mounting points of the components provided for this purpose.
- » Before working with electrical parts with voltage potentials higher than 50 V, the device must be disconnected from the mains voltage or power supply unit. Provide a safeguard to prevent reconnection.
- » With electrical drive and filter components, observe the following:
 - Wait 30 minutes after switching off power to allow capacitors to discharge before beginning to work. Measure the voltage on the capacitors before beginning to work to make sure that the equipment is safe to touch.
- » Never touch the electrical connection points of a component while power is turned on.
- » Install the covers and guards provided with the equipment properly before switching the device on. Before switching the equipment on, cover and safeguard live parts safely to prevent contact with those parts.
- » A residual-current-operated circuit-breaker or r.c.d. cannot be used for electric drives! Indirect contact must be prevented by other means, for example, by an overcurrent protective device according to the relevant standards.
- » Secure built-in devices from direct touching of electrical parts by providing an external housing, for example a control cabinet.

With electrical drive and filter components, observe the following:

High housing voltage and large leakage current! Risk of death or bodily injury by electric shock!



- » Before switching on, the housings of all electrical equipment and motors must be connected or grounded with the equipment grounding conductor to the grounding points. This is also applicable before short tests.
- » The equipment grounding conductor of the electrical equipment and the units must be non-detachably and permanently connected to the power supply unit at all times. The leakage current is greater than 3.5 mA.
- » Over the total length, use copper wire of a cross section of a minimum of 10 mm² for this equipment grounding connection!
- » Before start-up, also in trial runs, always attach the equipment grounding conductor or connect with the ground wire. Otherwise, high voltages may occur at the housing causing electric shock.

Protection against Electric Shock by Protective Low Voltage (PELV)

All connections and terminals with voltages between 5 and 50 Volt at PMC products are protective extra-low voltage systems which are provided with touch guard according to the product standards.

High electric voltage by incorrect connection! Risk of death or bodily injury by electric shock!



- » To all connections and terminals with voltages between 0 and 50 Volt, only devices, electrical components, and conductors may be connected which are equipped with a PELV (Protective Extra-Low Voltage) system.
- » Connect only voltages and circuits which are safely isolated from dangerous voltages. Safe isolation is achieved for example by isolating transformers, safe optocouplers or battery operation without mains connection.

Protection against Dangerous Movements

Dangerous movements can be caused by faulty control of connected motors. Some common examples are:

- » improper or wrong wiring of cable connections
- » incorrect operation of the equipment components
- » wrong input of parameters before operation
- » malfunction of sensors, encoders and monitoring devices
- » defective components
- » software or firmware errors

Dangerous movements can occur immediately after equipment is switched on or even after an unspecified time of trouble-free operation. The monitoring in the drive components will normally be sufficient to avoid faulty operation in the connected drives. Regarding personal safety, especially the danger of bodily harm and material damage, this alone cannot be relied upon to ensure complete safety. Until the integrated monitoring functions become effective, it must be assumed in any case that faulty drive movements will occur. The extent of faulty drive movements depends upon the type of control and the state of operation.

Dangerous movements! Danger to life, risk of injury, severe bodily harm or material damage!



- » For the above reasons, ensure personal safety by means of qualified and tested higher-level monitoring devices or measures integrated in the installation. They have to be provided for by the user according to the specific conditions within the installation and a hazard and fault analysis. The safety regulations applicable for the installation have to be taken into consideration. Unintended machine motion or other malfunction is possible if safety devices are disabled, bypassed or not activated.

To avoid accidents, bodily harm and/or material damage:

- » Keep free and clear of the machine's range of motion and moving parts. Possible measures to prevent people from accidentally entering the machine's range of motion are **using safety fences, using safety guards, using protective coverings** and **installing light curtains or light barriers**
- » Fences and coverings must be strong enough to resist maximum possible momentum.
- » Mount the emergency stop switch in the immediate reach of the operator. Verify that the

emergency stop works before startup. Don't operate the device if the emergency stop is not working.

- » Isolate the drive power connection by means of an emergency stop circuit or use a safety related starting lockout to prevent unintentional start.
- » Make sure that the drives are brought to a safe standstill before accessing or entering the danger zone.
- » Additionally secure vertical axes against falling or dropping after switching off the motor power by, for example, **mechanically securing the vertical axes, adding an external braking/arrester/ clamping mechanism or ensuring sufficient equilibration of the vertical axes**
- » The standard equipment motor brake or an external brake controlled directly by the drive controller are not sufficient to guarantee personal safety!
- » Disconnect electrical power to the equipment using a master switch and secure the switch against reconnection for **maintenance, repair work, cleaning of equipment and long periods of discontinued equipment use.**
- » Prevent the operation of high-frequency, remote control and radio equipment near electronics circuits and supply leads. If the use of such devices cannot be avoided, verify the system and the installation for possible malfunctions in all possible positions of normal use before initial startup. If necessary, perform a special electromagnetic compatibility (EMC) test on the installation.

Protection against Magnetic and Electromagnetic Fields during Operation and Mounting

Magnetic and electromagnetic fields generated by current-carrying conductors and permanent magnets in motors represent a serious personal danger to those with heart pacemakers, metal implants and hearing aids.

Health hazard for persons with heart pacemakers, metal implants and hearing aids in proximity to electrical equipment!



- » Persons with heart pacemakers and metal implants are not permitted to enter following areas:
 - Areas in which electrical equipment and parts are mounted, being operated or commissioned.
 - Areas in which parts of motors with permanent magnets are being stored, repaired or mounted.
- » If it is necessary for somebody with a pacemaker to enter such an area, a doctor must be consulted prior to doing so. The interference immunity of present or future implanted heart pacemakers differs greatly, so that no general rules can be given.
- » Those with metal implants or metal pieces, as well as with hearing aids must consult a doctor before they enter the areas described above. Otherwise health hazards may occur.

Protection against Contact with Hot Parts

Hot surfaces at motor housings, on drive controllers or chokes! Danger of injury! Danger of burns!



- » Do not touch surfaces of device housings and chokes in the proximity of heat sources! Danger of burns!

- » Do not touch housing surfaces of motors! Danger of burns!
- » According to operating conditions, temperatures can be higher than 60 °C, 140 °F during or after operation.
- » Before accessing motors after having switched them off, let them cool down for a sufficiently long time. Cooling down can require up to 140 minutes! Roughly estimated, the time required for cooling down is five times the thermal time constant specified in the Technical Data.
- » After switching drive controllers or chokes off, wait 15 minutes to allow them to cool down before touching them.
- » Wear safety gloves or do not work at hot surfaces.
- » For certain applications, the manufacturer of the end product, machine or installation, according to the respective safety regulations, has to take measures to avoid injuries caused by burns in the end application. These measures can be, for example: warnings, guards (shielding or barrier), and technical documentation.

Protection during Handling and Mounting

In unfavorable conditions, handling and assembling certain parts and components in an improper way can cause injuries.

Risk of injury by improper handling! Bodily injury by bruising, shearing, cutting, hitting!



- » Observe the general construction and safety regulations on handling and assembly.
- » Use suitable devices for assembly and transport.
- » Avoid jamming and bruising by appropriate measures.
- » Always use suitable tools. Use special tools if specified.
- » Use lifting equipment and tools in the correct manner.
- » If necessary, use suitable protective equipment (for example safety goggles, safety shoes, safety gloves).
- » Do not stand under hanging loads.
- » Immediately clean up any spilled liquids because of the danger of skidding.

2 TECHNICAL SPECIFICATIONS

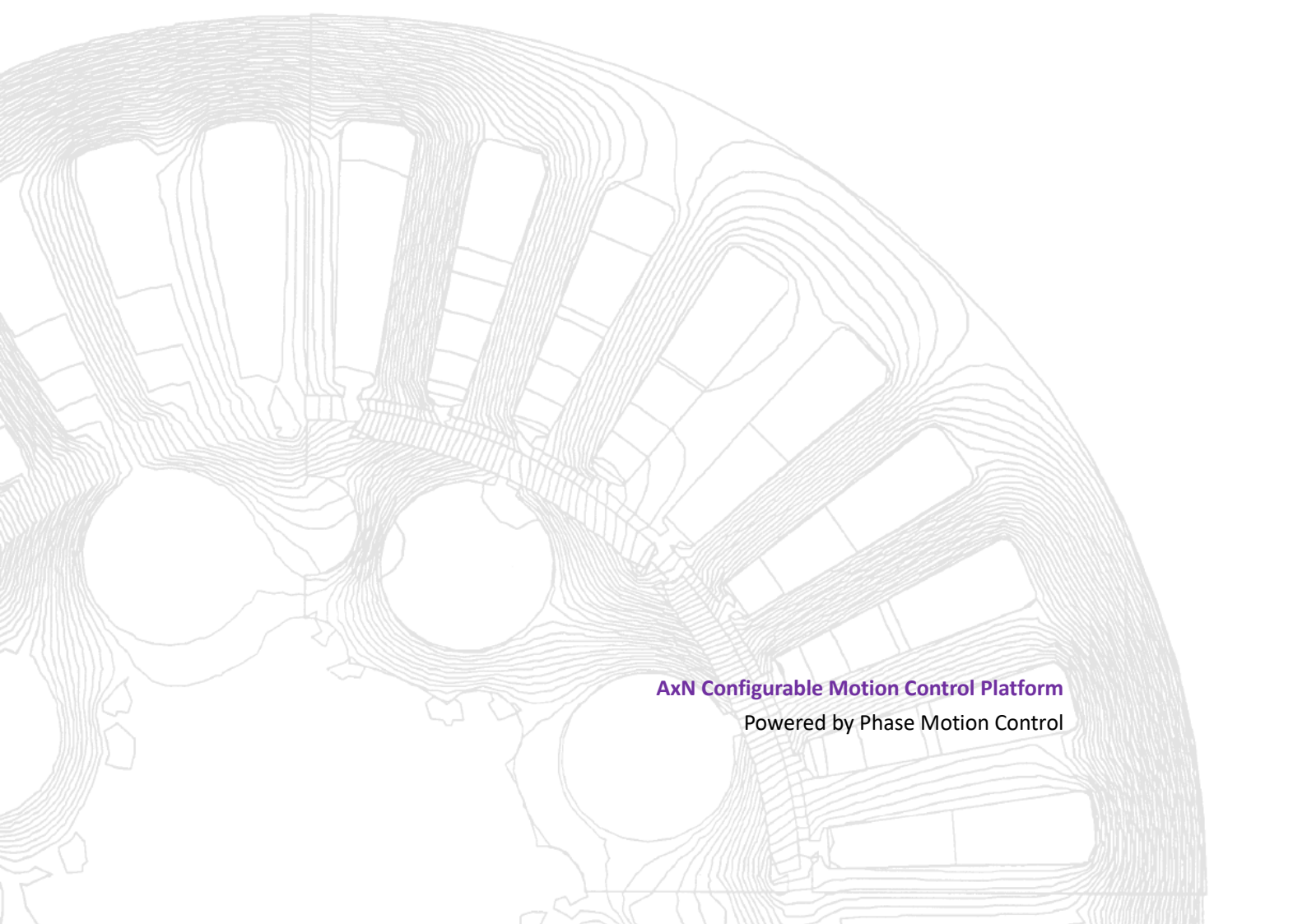

2.1 Specifications

Specifications

Technical specifications	Symbol	AxN 09.20.4	Units
Power Supply Voltage	V_{in}	150 ~ 500	Vac 3 phase
		0 ~ 800	Vdc
Auxiliary supply voltage	V_{aux}	24V ± 15% / 2A	Vdc
Output frequency	f	0 ~ 1200	Hz
Current output, S1 ⁽¹⁾	I_o	9	Arms
Peak current ⁽¹⁾	I_p	20	Arms
Power Losses total ⁽²⁾	P_l	200	W
Maximum output voltage	V_{out}	$V_{in} \times 0.95$	Vac
PWM frequency ⁽³⁾	f_{pwm}	4 / 8 / 16	kHz
Efficiency at nominal power ⁽¹⁾	--	97.9	%
Input form factor (Full load)	--	0.9	Vac 3 phase
Maximum braking current	--	100% of I_p (peak current)	--
Cooling	--	1 fan 40 × 40 × 20	--
Flow rate	--	25.2	m ³ /hour
Dimensions (H×W×D)	--	201.8×96×164.6	mm

(1) $V_{in} = 380$ Vac, $V_{out} = V_{in} \times 0.95$, $T_{amb} = 40^\circ\text{C}$, Comm.Freq.8kHz

(2) Including input rectifier losses

(3) PWM frequency will automatically decrease at Zero Speed, in order to keep Nominal Current Output

Motor Feedback Options

Main Encoder (500kHz)	Sincos encoder 5 channels (2 absolute analog tracks/2 incremental analog tracks/index)
	Incremental encoder (1 Vpp or Different Line Driver)
	Sensorless algorithm (w/o feedback)
	Endat serial encoder 1.0 to 2.2 (default)
	Resolver
	Hiperface encoder
Secondary Encoder (500kHz)	Incremental digital encoder without commutation tracks (500kHz)
	Endat serial encoder

Programmable Input Signals

2 Differential analog inputs	± 10V (1mV) / $R_{in} = 10\text{k}\Omega$
8 digital inputs	20 ~ 30V / $R_{in} = 6.6\text{k}\Omega$ to GND

Programmable Output Signals

2 analog outputs	0 ~ 10V (1mV) FS (30mA)
4 digital outputs	PNP open collector 24V (100mA)
1 watch dog relay	2A/30Vdc, 0.25A/250Vac, NO/NC contacts

Hardware Configuration

Processor speed: 80 MIPS μ C + FPGA

120 MIPS μ C + FPGA Extreme Version (Optional)

Task frequency:

- Current /drive monitoring: 1 MHz
- Position/speed loop: 8 kHz
- PLC fast task: 8 kHz
- PLC slow task: 15.625 Hz to 1 kHz user-programmable

Position loop mode available

Target position register: 32 or 64 bits

Full digital control Id/Iq, updated 16 kHz

Drive Operational Area

Max Current VS. Ambient Temperature

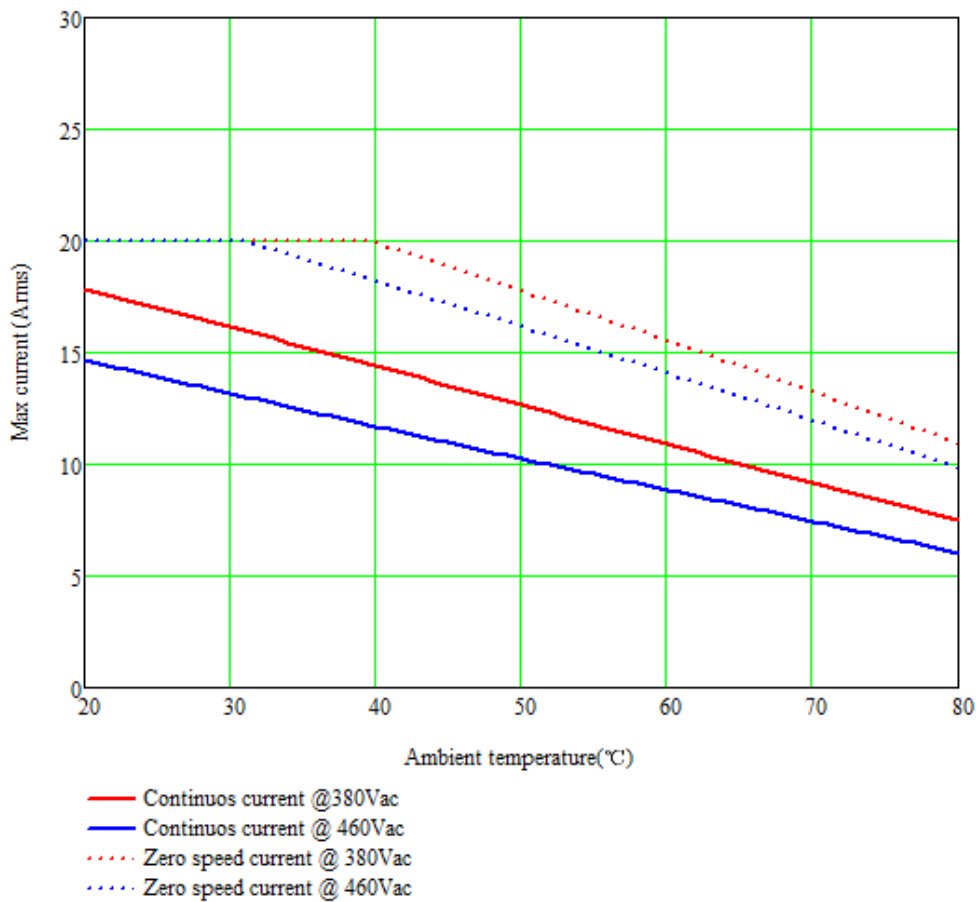

MAX CURRENT VS AMBIENT TEMPERATURE

Max Continuous Current VS. Output Voltage (at 40°C)

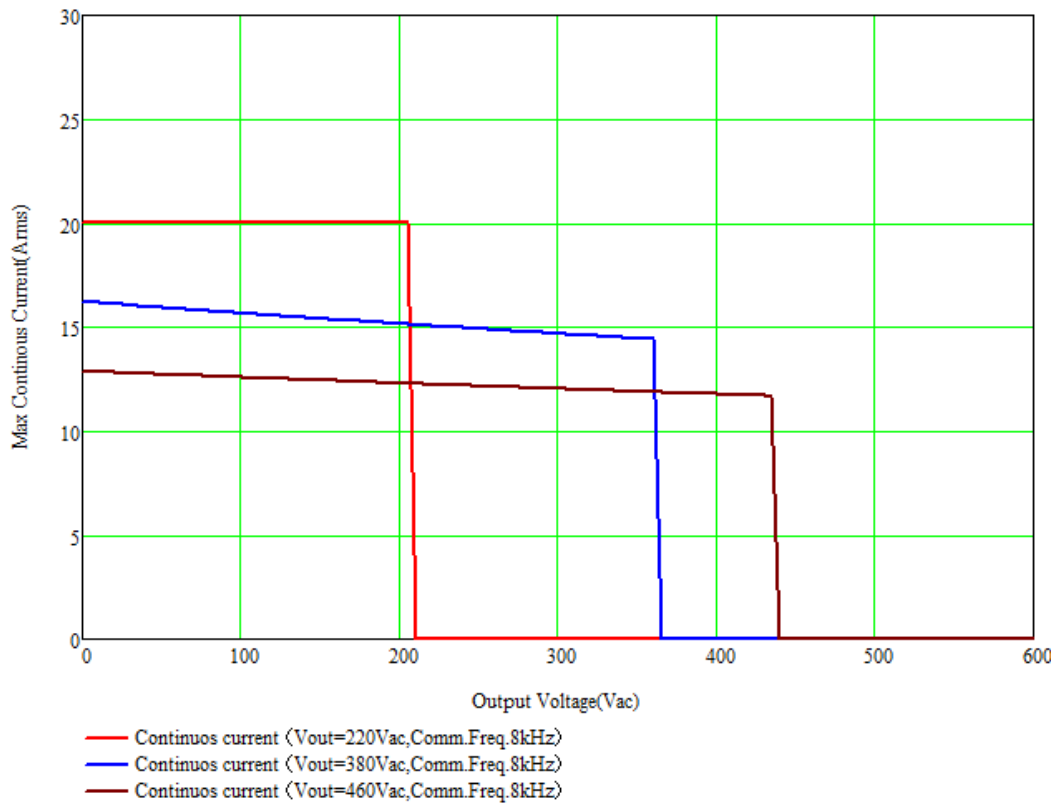

CONTINUOUS AND PEAK CURRENT VS OUTPUT VOLTAGE AT 40 C AMBIENT

2.2 Ambient Conditions

Ambient Conditions

Ambient Conditions	AxN 09.20.4
Protection	IP20
Accident Prevention Regulations	According to local regulations
Mounting Altitude	Up to 1000m above MSL, over 1000m above MSL with power reduction (1% per 100m up)
Pollution Severity	2
Installation Type	Built-in unit, only for vertical installation in a switch cabinet with min. IP4x protection
Environment	Far away from corrosive, flammable gases, droplets of oil or dust etc.

Climatic Conditions

Climatic Conditions	AxN 09.20.4	
In Transit	As per EN 61800-2, IEC 60721-3-2 class 2K3 ⁽¹⁾	
	Temperature	-25°C to +85°C
	Relative air humidity	5 to 90% without condensation

In Storage	As per EN 61800-2, IEC60721-3-1 class 1K3 和 1K4 ⁽²⁾	
	Temperature	-25°C to +85°C
	Relative air humidity	5 to 95% without condensation
In Operation	As per EN 61800-2, IEC60721-3-3 class 3K3 ⁽³⁾	
	Temperature	0°C to 40°C, up to 60°C with power reduction
	Relative air humidity	5 to 95% without condensation

- (1) The absolute humidity is limited to max. 60 g/m³. This means, at 70 °C for example, that the relative humidity may only be max. 40 %.
- (2) The absolute humidity is limited to max. 29 g/m³. So the maximum values for temperature and relative air humidity stipulated in the table must not occur simultaneously.
- (3) The absolute humidity is limited to max. 25 g/m³. That means that the maximum values for temperature and relative air humidity stipulated in the table must not occur simultaneously.

Mechanical Conditions

Mechanical Conditions	AxN 09.20.4		
Vibration Limit in Transit	As per EN 61800-2, IEC 60721-3-2 class 2M1		
	Frequency (Hz)	Amplitude (mm)	Acceleration (m/s²)
	$2 \leq f < 9$	3.5	Not Applicable
	$9 \leq f < 200$	Not Applicable	10
	$200 \leq f < 500$	Not Applicable	15
Shock Limit in Transit	As per EN 61800-2, IEC 60721-2-2 class 2M1		
	Drop height of packed device max. 0.25m		
Vibration Limit of the system ⁽¹⁾	As per EN 61800-2, IEC 60721-3-3 class 3M1		
	Frequency (Hz)	Amplitude (mm)	Acceleration (m/s²)
	$2 \leq f < 9$	0.3	Not Applicable
	$9 \leq f < 200$	Not Applicable	1

- (1) NOTE: The devices are only designed for stationary use.

3 MECHANICAL INSTALLATION

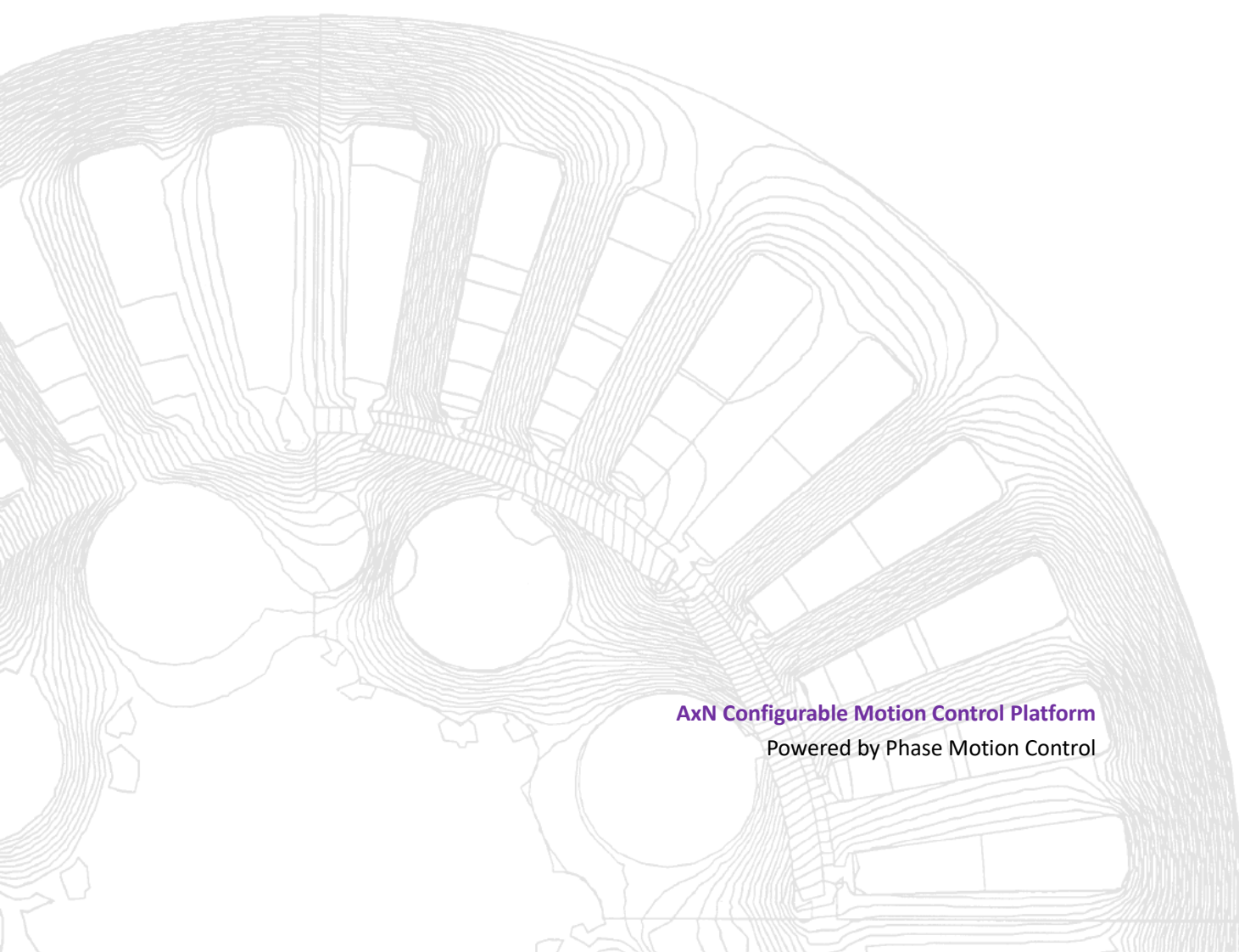

3.1 Notes for Operation

Avoid

Please be sure to avoid:

1. penetration of damp into the device;
2. aggressive or conductive substances in the immediate vicinity;
3. explosive and flammable substances in the immediate vicinity;
4. drill chippings, screws or foreign bodies dropping into the device;
5. ventilation openings being covered over, as otherwise the device may be damaged

Note

Note the following points:

1. Make sure every part of the drive is anchored before moving the drive. Failure to comply may result in minor or moderate injury from the drive parts falling.
2. Observe proper electrostatic discharge (ESD) procedures when handling the drive. Failure to comply could result in ESD damage to the drive circuitry;
3. Prevent foreign matter such as metal shavings or wire clippings from falling into the drive during installation and project construction. Failure to comply could result in damage to the drive. Place a temporary cover over the top of the drive during installation. Remove the temporary cover before start-up, as the cover will reduce ventilation and cause the drive to overheat.
4. Install proper cooling to ensure the temperature in the enclosure does not exceed 40 °C.

3.2 Installation Environment

To help prolong the optimum performance life of the drive, install the drive in the proper environment. The table below provides description of the appropriate environment for the drive.

Environment	Condition
Installation Area	Indoor
Ambient Temperature	0°C to 40°C, up to 60°C with power reduction (2%/°C) Drive reliability improves in environments without wide temperature fluctuations. When using an enclosure panel, install a cooling fan or air conditioner in the area to ensure that the air temperature inside the enclosure does not exceed the specified levels. Do not allow ice to develop on the drive.
Humidity	5 to 95% without condensation
Surrounding Area	Install the drive in an area free from: <ol style="list-style-type: none"> 1. oil mist and dust 2. metal shavings, oil, water or other foreign materials 3. radioactive materials 4. combustible materials (e.g., wood)

	<ul style="list-style-type: none"> 5. harmful gases and liquids 6. excessive vibration 7. chlorides
Altitude	Up to 1000m above MSL, over 1000m above MSL with power reduction (1% per 100m up)
Vibration	Amplitude up to 0.3mm at 2 to 9 Hz Acceleration up to 1m/s ² at 9 to 200 Hz
Orientation	Install the drive vertically to maintain maximum cooling effects.

3.3 Overall Dimensions

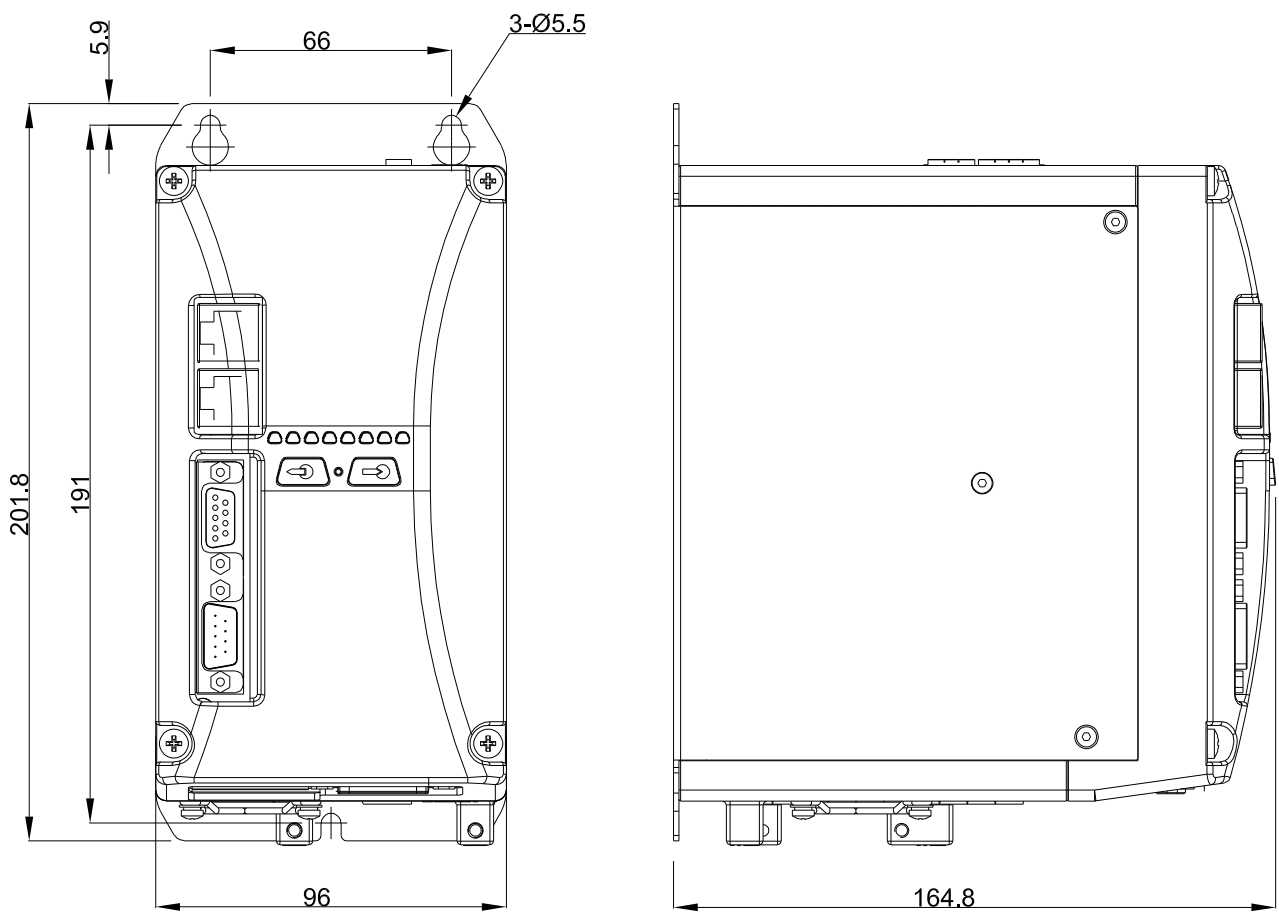

Overall Dimensions

3.4 Installation Orientation and Spacing

Installation Orientation

To maintain proper cooling, install the AxN drive upright inside the switch cabinet as illustrated below:

WARNING: The airflow inside the drive must be upright after installation as illustrated below. If other form of installation must be taken, CONNECT PMC ENGINEER BEFORE INSTALLATION.

Correct

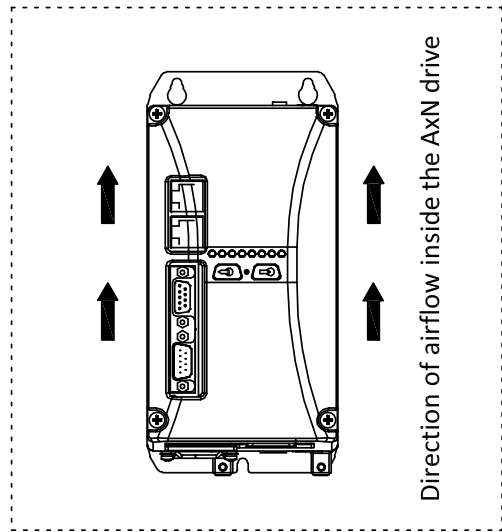

Incorrect

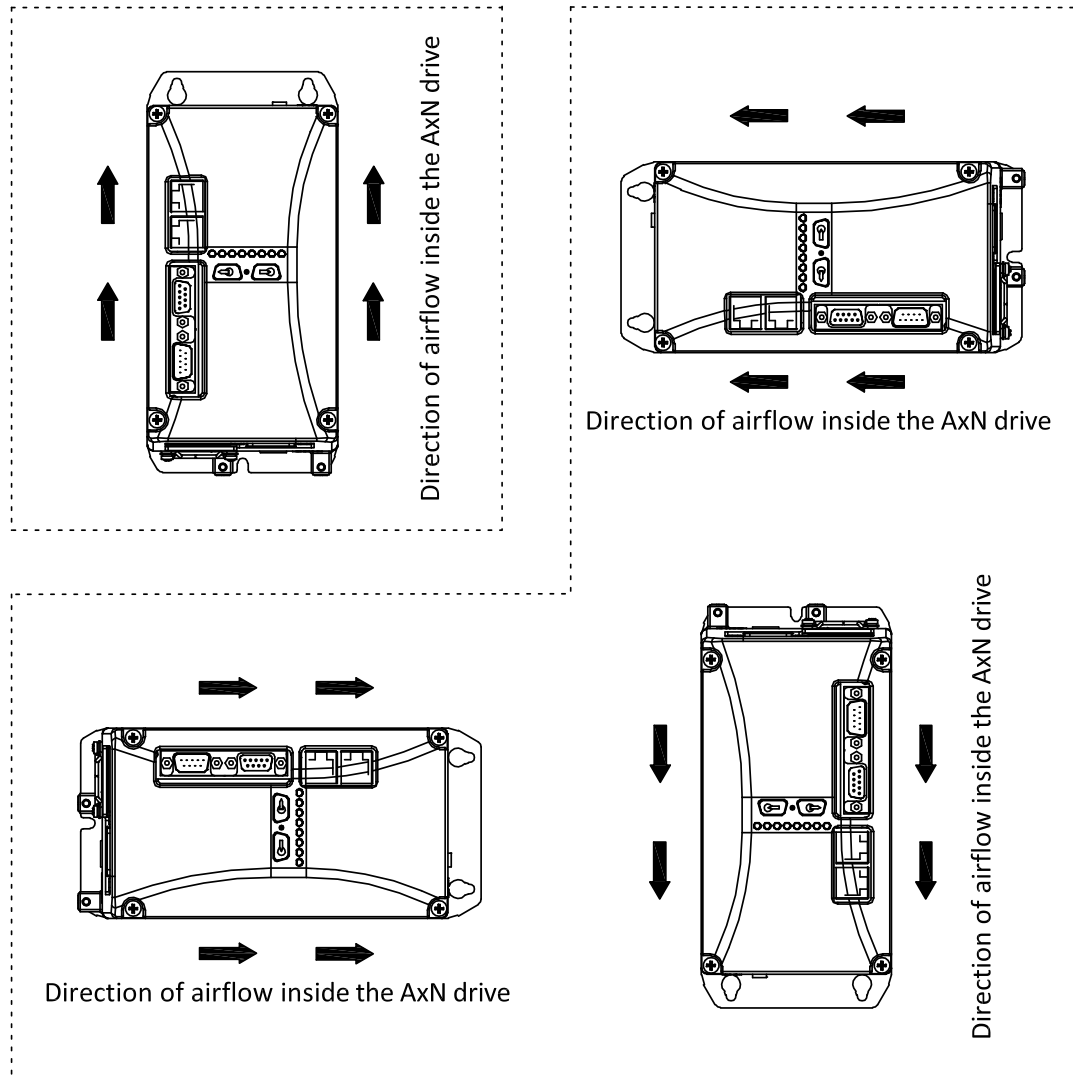

Installation Orientation

Installation Spacing

To maintain sufficient space for airflow and wiring, the space between AxN drive and other device (including other AxN drives) must comply the requirement below.

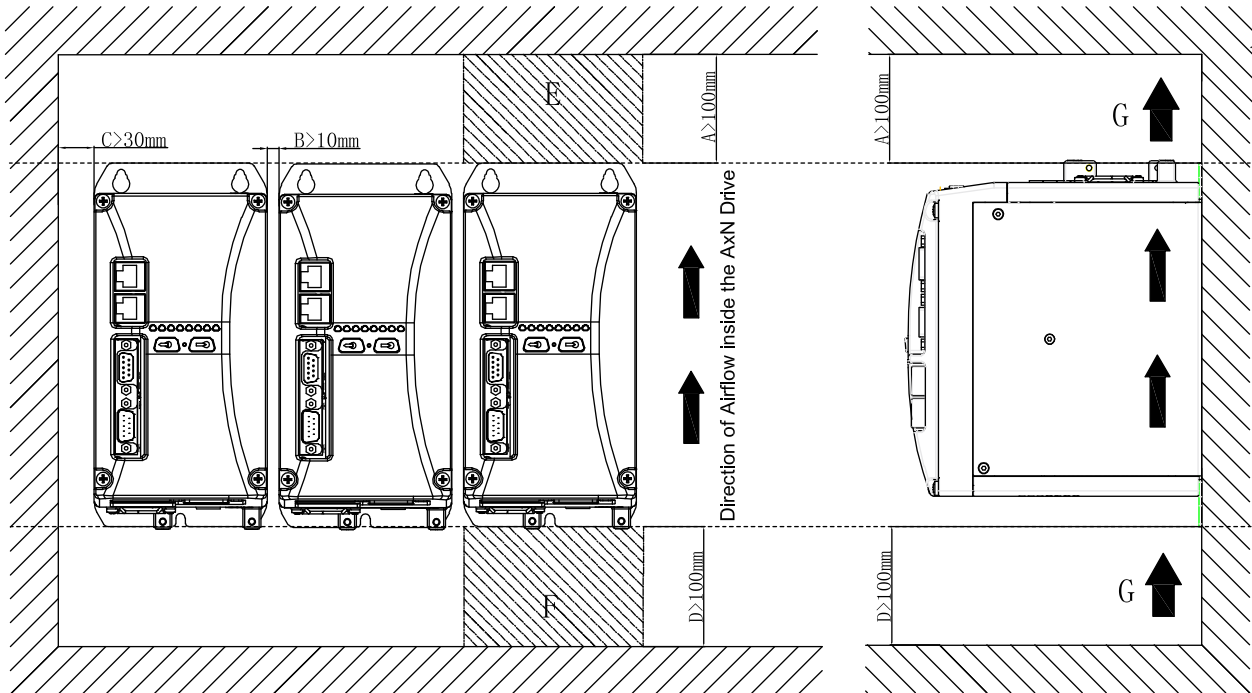

Installation Spacing

No.	Distance	Description
A	> 100mm	The distance between the top of the switch cabinet, to ensure enough space for air-out.
B	> 10mm	The distance between other device (including other AxN drives and peripheral devices)
C	> 30mm	The distance between the inside wall of the switch cabinet.
D	> 100mm	The distance between the bottom of the switch cabinet, to ensure enough space for air-in.
E	> 100mm	Air-out area, do not place any other device in this area
F	> 100mm	Air-in area, do not place any other device in this area
G		Airflow Direction

NOTE: The switch cabinet must have air outlets and inlets to ensure the thermal exchange between the cold air outside and the hot air inside.

4 ELECTRICAL INSTALLATION

4.1 Standard Connection Diagram

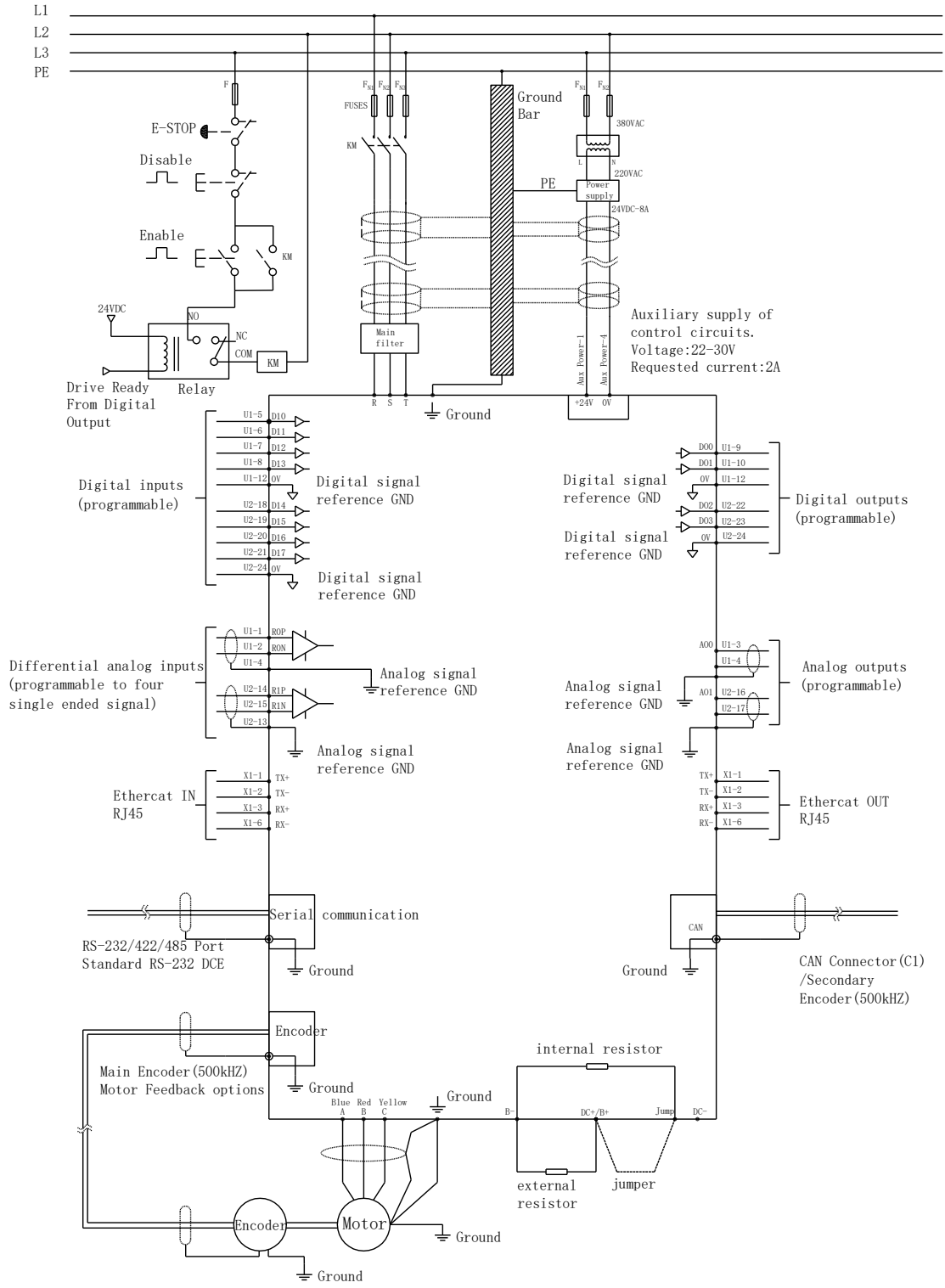

4.2 Main Circuit

4.2.1 Main Circuit Connection Diagram

AxN 09.20.4 Drive can use AC power or DC power as its power supply. **DO NOT USE BOTH AC power supply and DC power supply AT THE SAME TIME!** Refer to the following figures for standard drive connection diagram.

NOTE: the input and output ports in the following figures do not represent the true location on the drive, please refer [4.2.2 Power Supply Input Port](#) and [4.2.6 Motor Power Output Port](#) to know more details.

AC Power Supply

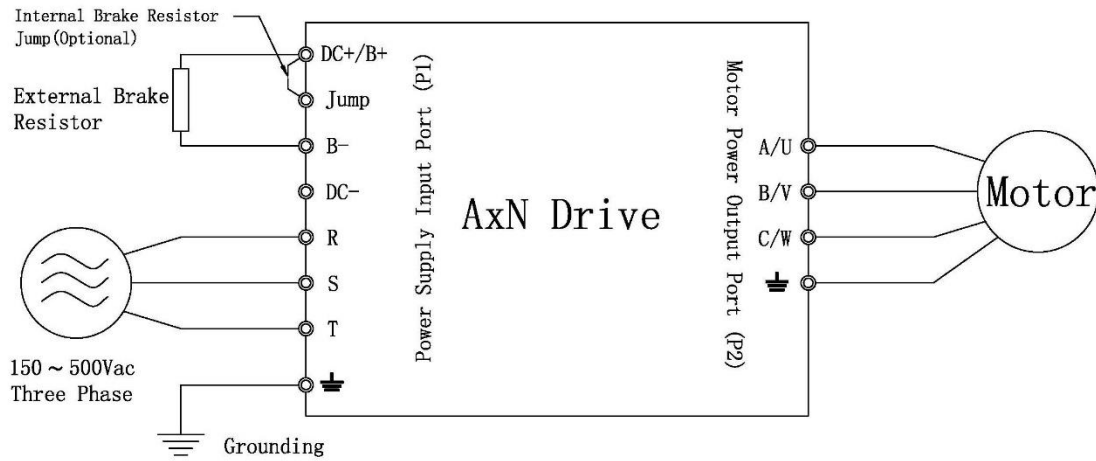

Main Circuit Connection Diagram: AC Power

DC Power Supply

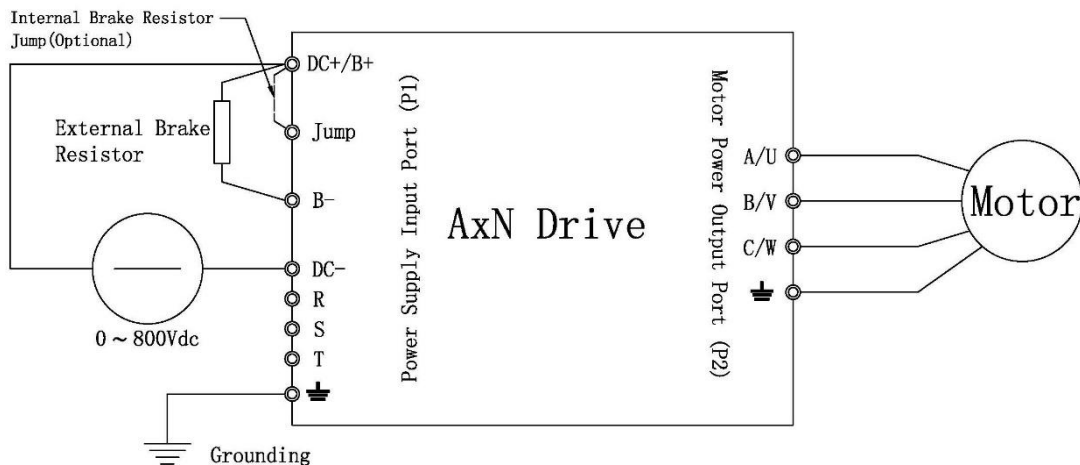

Main Circuit Connection Diagram: DC Power

4.2.2 Power Supply Input Port (P1)

AxN 09.20.4 Drive's Power Supply Input Port (P1) has 4 functions: **AC Power Supply Input**, **DC Power Supply Input**, **External Brake Resistor Connection** and **Internal Brake Resistor Activation**.

Port Location

AxN 09.20.4 Drive's Power Supply Input Port (P1) is on the bottom of the drive. Refer to the following figure for exact locations.

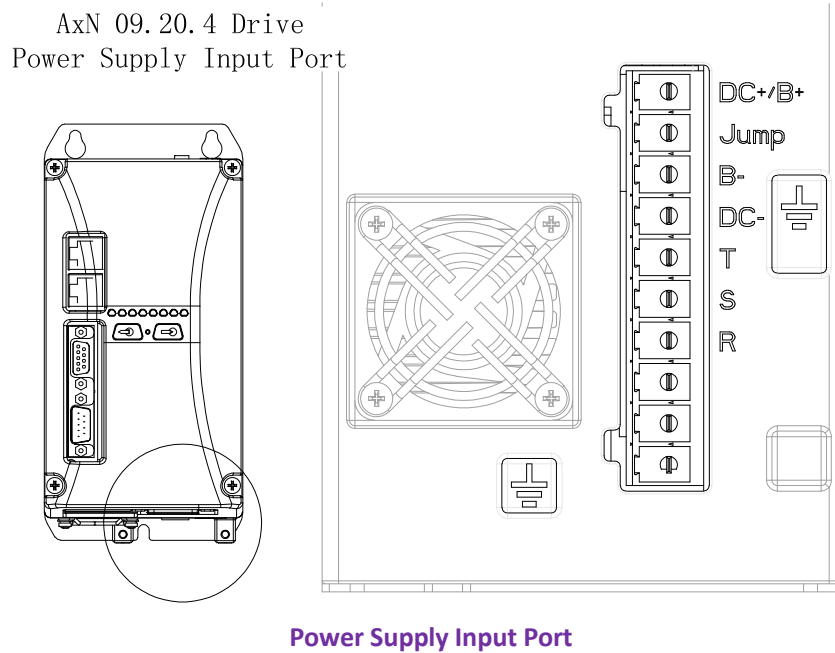

Terminal Configuration

AxN 09.20.4 Drive's Power Supply Input Port (P1) has 8 terminals: PE, R, S, T, DC-, B-, Jump and DC+/B+ (the PE terminal is a shared PE terminal). And the P1 port has different functions by using different combinations of terminals. Refer to following table for more details:

Function	Terminal	Definition	Description
AC Power Supply Input	T	Three phase AC power supply: phase	150 ~ 500 Vac three phase AC power supply
	S	Three phase AC power supply: phase	
	R	Three phase AC power supply: phase	
	PE	Three phase AC power supply: grounding	
DC Power Supply Input	DC+/B+	DC power supply: positive (+)	0 ~ 800 Vdc DC power supply
	DC-	DC power supply: negative (-)	
	PE	DC power supply: grounding	
External Brake Resistor	DC+/B+	External brake resistor: positive (+)	More details refer to 4.2.5 Brake Resistor
	B-	External brake resistor: negative (-)	
Internal Brake Resistor	DC+/B+	Internal brake resistor: positive (+)	More details refer to 4.2.5 Brake Resistor
	Jump	Internal brake resistor: negative (-)	

4.2.3 AC Power Supply Input

AC Power Supply Requirement

Mains Supply	AxN 09.20.4
Voltage	150 ~ 500V
Type	Three-phase AC power
Frequency	50/60Hz
Fluctuation of Frequency	±10% (45 ~ 66Hz)
Asymmetry	±3%

Cable

Wire Gauge

AxN 09.20.4 drive must use a 4 wire cable with shield as its AC power supply cable. The table below lists the appropriate cable:

	Current (Arms)	Cross-sectional Area (mm ²)	AWG
AxN 09.20.4	9	2.63	13

Pre-insulated Crimp Terminals

Crimping pre-insulated Terminals on the wires will enhance the connection stability and simplicity between the cable and drive. R, S, T terminals of AxN 09.20.4 drive are recommended to use the E Series Cord End Terminals manufactured by KST. And PE terminal is recommended to use the RNY Series Ring Terminals also manufactured by KST. The table below lists the appropriate terminal:

	Recommended Pre-insulated Crimp Terminals	Recommended Strip Length(mm)
AxN 09.20.4	E2508 (phase wire) / RNYBS22-6 (ground wire)	10

Cable Shield Grounding

Wiring the cable shield to ground is a very helpful method to reduce interference. Follow these two precautions to ground the cable shield: 1. Pull out some shield and fix it on the outside of the cable with heat-shrink tube; 2. Use a drainage line to connect the Cable Shield and PE wire.

Cable Sketch

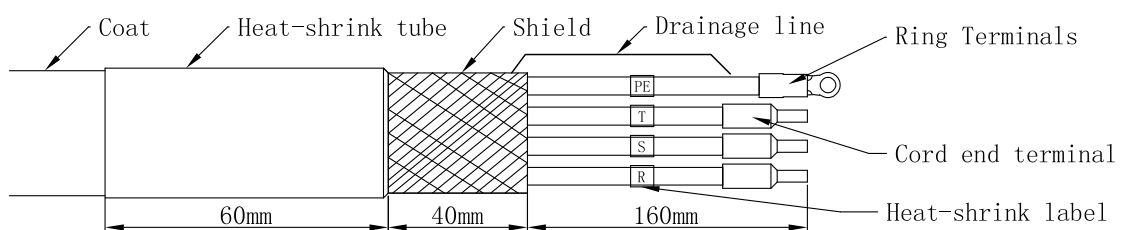

AC Power Supply Cable Sketch

AC Power Installation

Wiring and Torque Specification

Connect the 4 wires of the AC power supply cable to the correspond terminals on the P1 port: **T to T, S to S, R to R and PE to PE.**

Cable Fixing

Use a hose clamp to fix the cable on the cable support. For AxN 09.20.4 drive, the nominal torque to tight these terminals is 0.5 ~ 0.6 N·m.

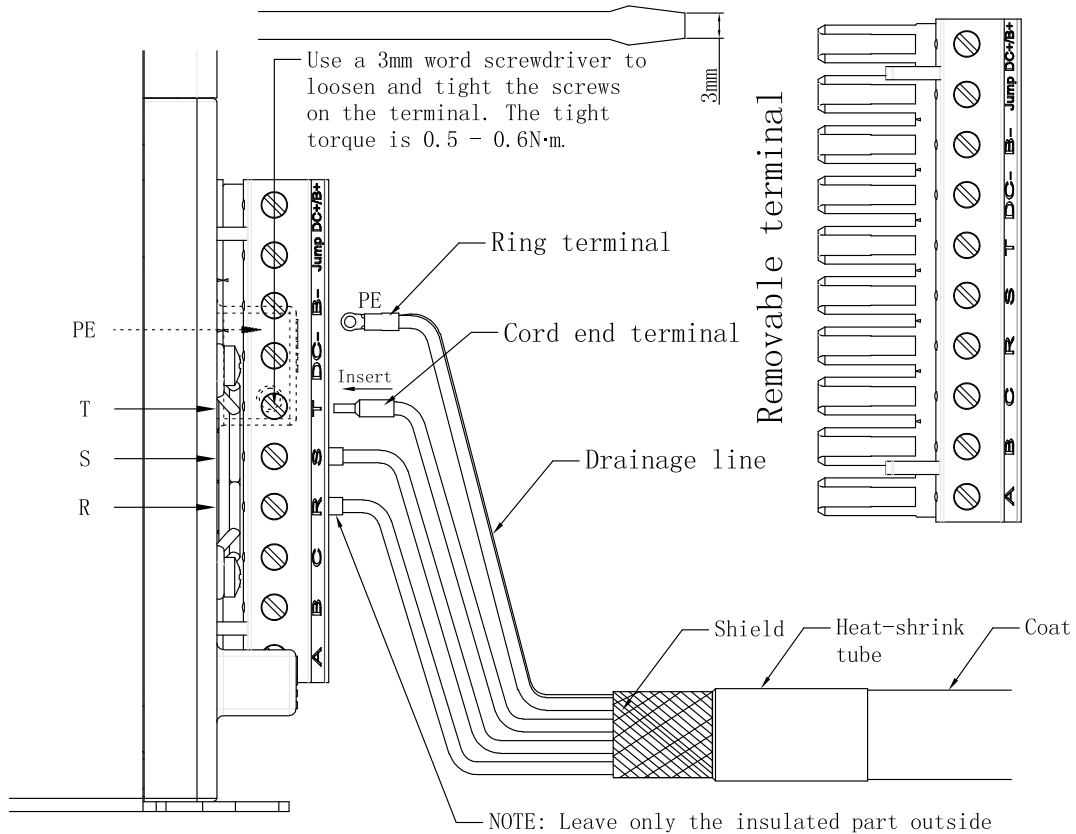

AC Power Supply Cable Installation

4.2.4 DC Power Supply Input

DC Power Supply Requirement

Main Supply	AxN 09.20.4
Voltage	565V
Type	DC power
Fluctuation of Voltage	0 ~ 800V
Nominal Current Output	9A
Peak Current Output	20A
Nominal Power at 565V	6.3KW
Peak Power at 565V	13.8KW

Note: please do not install filters, reactors and other equipment between DC power and AxN drive. Connect DC power and AxN drive directly with the power line.

Cable

Wire Gauge

AxN 09.20.4 drive must use a 3 wire cable with shield as its DC power supply cable. The table below lists the appropriate cable:

	Current (Arms)	Cross-sectional Area (mm ²)	AWG
AxN 09.20.4	10.4	2.63	13

Pre-insulated Crimp Terminals

Crimping pre-insulated Terminals on the wires will enhance the connection stability and simplicity between the cable and drive. DC+ and DC- terminals of AxN 09.20.4 drive are recommended to use the E Series Cord End Terminals manufactured by KST. And PE terminal is recommended to use the RNY Series Ring Terminals also manufactured by KST. The table below lists the appropriate terminal:

	Recommended Pre-insulated Crimp Terminals	Recommended Strip Length(mm)
AxN 09.20.4	E2508 (phase wire) / RNYBS22-6 (ground wire)	10

Cable Shield Grounding

Wiring the cable shield to ground is a very helpful method to reduce interference. Follow these two precautions to ground the cable shield: 1. Pull out some shield and fix it on the outside of the cable with heat-shrink tube; 2. Use a drainage line to connect the Cable Shield and PE wire.

Cable Sketch

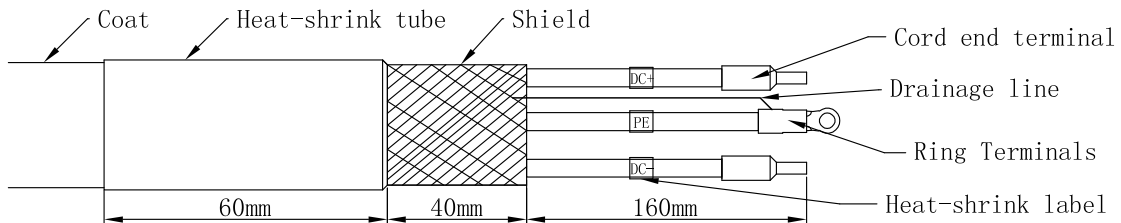

DC Power Supply Cable Sketch

DC Power Installation

Wiring and Torque Specification

Connect the 3 wires of the DC power supply cable to the correspond terminals on the P1 port: **DC+ to DC+/B+, DC- to DC- and PE to PE.**

Cable Fixing

Use a hose clamp to fix the cable on the cable support. For AxN 09.20.4 drive, the nominal torque to tight these terminals is 0.5 ~ 0.6 N·m.

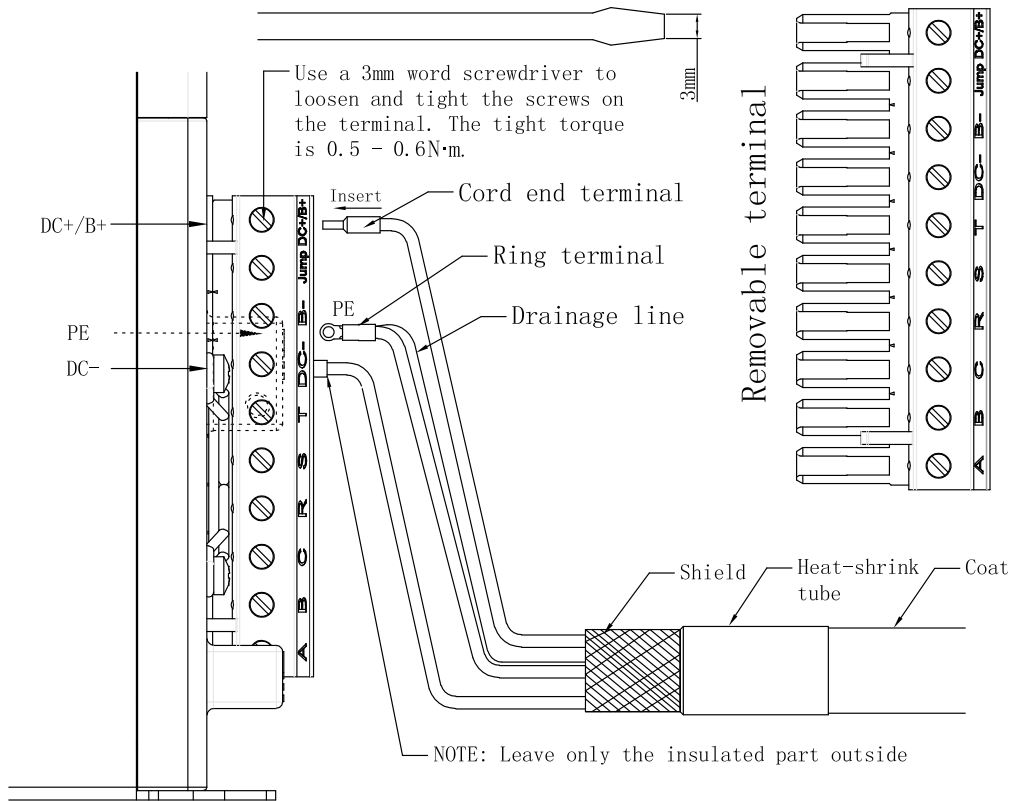

DC Power Supply Cable Installation

4.2.5 Brake Resistor

Dynamic braking (DB) helps bring the motor to a smooth and rapid stop when working with high inertia loads. As the drive lowers the frequency of a motor with high inertia connected, regeneration occurs. This can cause an overvoltage situation when the regenerative energy flows back into the DC bus capacitors. A brake resistor prevents these overvoltage faults.

AxN 09.20.4 Drive has an internal brake resistor inside the drive. And it can also connect an external brake resistor (Recommended).

WARNING: Do not operate AxN Drive without any brake resistor. Failure to comply may result in damage to braking circuit or drive.

Internal Brake Resistor

Specifications

Every AxN 09.20.4 Drive has an internal brake resistor. Regard to its properties, using internal brake resistor in real applications is **NOT** recommended. Refer to the following table for more details:

	Resistance (Ω)	Power (W)
AxN 09.20.4	30	30

Activation

Use the attached shortcut wire to connect the Terminals, **Jump** and **DC+/B+**, in order to activate the Internal Brake Resistor inside the AxN 09.20.4 Drive.

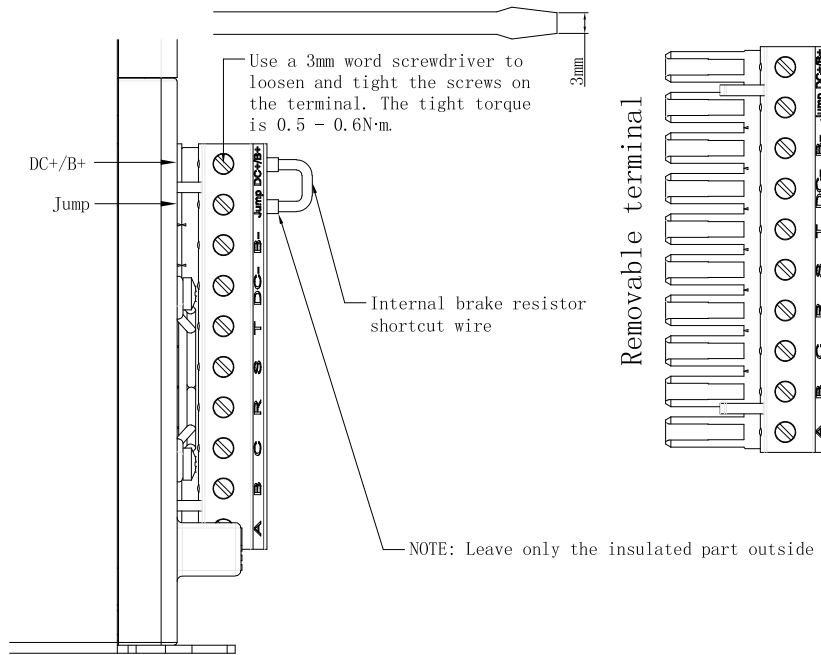

Internal Brake Resistor Activation

External Brake Resistor

The External Brake Resistor must be sized properly in order to dissipate the required power to decelerate the load in desired time. There are three important factors: **Resistance**, **Maximum Absorb Energy** and **Maximum Power**.

Resistance

The selection of the external brake resistor resistance must be proper. If the resistance is smaller than Minimum Resistance, the IGBT might be damaged by the overload brake current. And if the resistance is bigger than Maximum Resistance, the brake procedure might be abort because of the high DC-Bus Voltage (over 900V). Refer to following table to check the Minimum and Maximum Resistance of external brake resistor:

	Minimum Resistance (Ω)	Maximum Resistance (Ω)
AxN 09.20.4	19	30

Maximum Absorb Energy and Maximum Power

Maximum Absorb Energy and Maximum Power are two important factors to evaluate the energy absorption ability of the brake resistor. The values of these two factors may differ from one application to another, but the basic idea is always the same, to dissipate the required power to decelerate the load in desired time.

NOTE: Brake resistor wires' insulation grade must be higher than 1000Vac and 3000Vdc.

Installation

Connect the brake resistor's wires to the Terminals, **DC+/B+** and **B-**. For AxN 09.20.4 drive, the nominal torque to tight these terminals is 0.5 ~ 0.6 N·m.

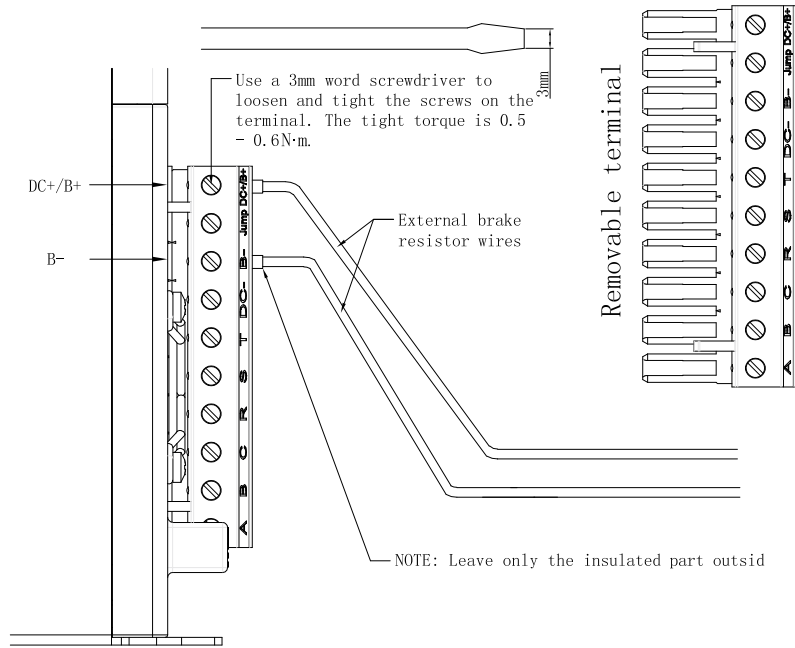

External Brake Resistor Installation

4.2.6 Motor Power Output Port (P2)

AxN 09.20.4 Drive's Motor Power Output Port (P2) has one function: output power to the motor.

Port Location

AxN 09.20.4 Drive's Motor Power Output Port (P2) is on the bottom of the drive. Refer to the following figure for exact locations.

AxN 09.20.4 Drive
Motor Power Output Port

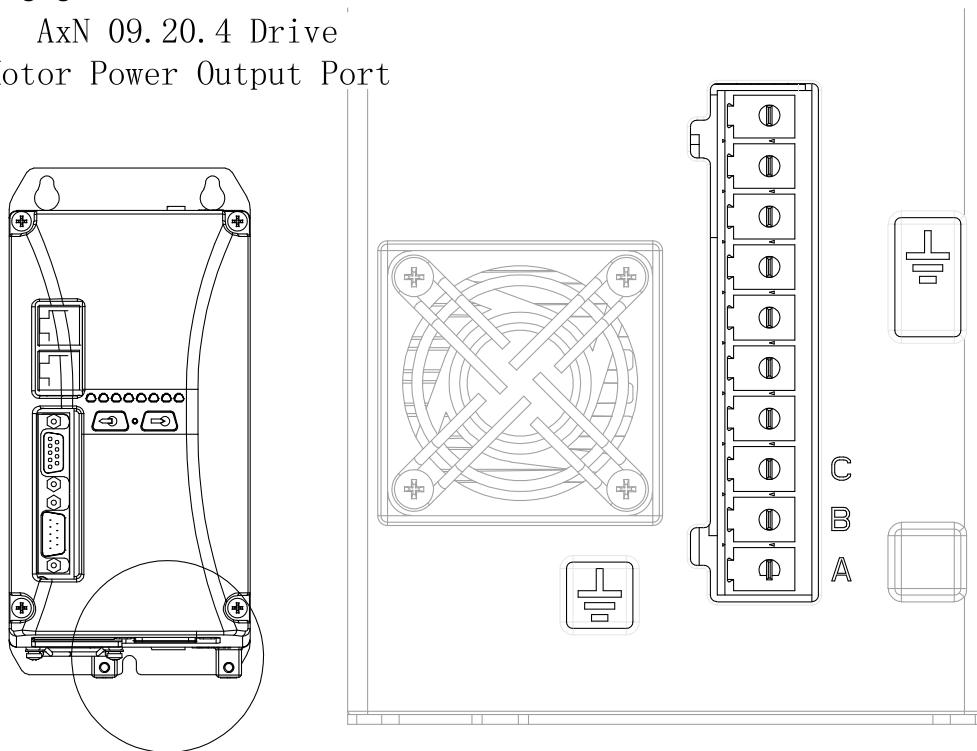

Motor Power Output Port

Terminal Configuration

AxN 09.20.4 Drive's Motor Power Output Port (P1) has 4 terminals: A, B, C and PE (the PE terminal is a shared PE terminal). The wires of the Motor Power Cable must correspond one to one with the terminals on the P2 port. Refer to following table for more details:

Motor Power Output Port (P2)	Motor Power Cable	Descriptions
A	U/1	Phase U wire must connect to A terminal
B	V/2	Phase V wire must connect to B terminal
C	W/3	Phase W wire must connect to C terminal
PE	PE	Ground protection

WARNING: The correspondence between the Motor Power Output wires and terminals should be adhered! Otherwise the motor cannot work properly!

4.2.7 Motor Power Output

Cable

Wire Gauge

AxN 09.20.4 drive must use a 4 wire cable with shield as its Motor Power Output cable. The table below lists the appropriate cable:

	Current (Arms)	Cross-sectional Area (mm ²)	AWG
AxN 09.20.4	9	4.17	11

Pre-insulated Crimp Terminals

Crimping pre-insulated Terminals on the wires will enhance the connection stability and simplicity between the cable and drive. A, B, C terminals of AxN 09.20.4 drive are recommended to use the E Series Cord End Terminals manufactured by KST. And PE terminal is recommended to use the RNY Series Ring Terminals also manufactured by KST. The table below lists the appropriate terminal:

	Recommended Pre-insulated Crimp Terminals	Recommended Strip Length(mm)
AxN 09.20.4	E4012 (phase wire) / RNYBS22-6 (ground wire)	14

Cable Shield Grounding

Wiring the cable shield to ground is a very helpful method to reduce interference. Follow these two precautions to ground the cable shield: 1. Pull out some shield and fix it on the outside of the cable with heat-shrink tube; 2. Use a drainage line to connect the Cable Shield and PE wire.

Cable Sketch

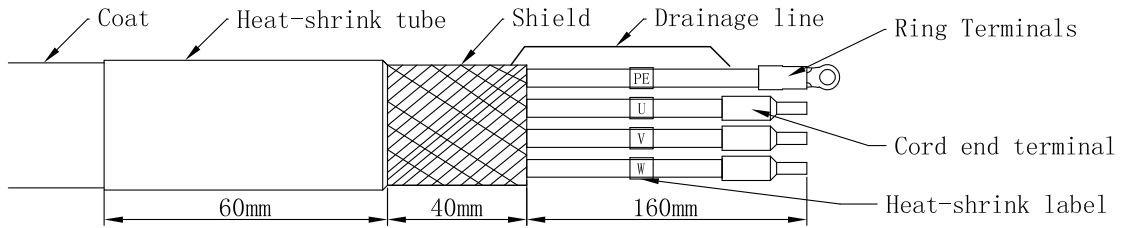

Motor Power Output Cable Sketch

Motor Power Output Installation

Wiring and Torque Specification

Connect the 4 wires of the motor power cable to the correspond terminals on the P2 port: **U to A, V to B, W to C and PE to PE.**

Cable Fixing

Use a hose clamp to fix the cable on the cable support. The nominal torque to tight these terminals is 0.5 ~ 0.6 N·m.

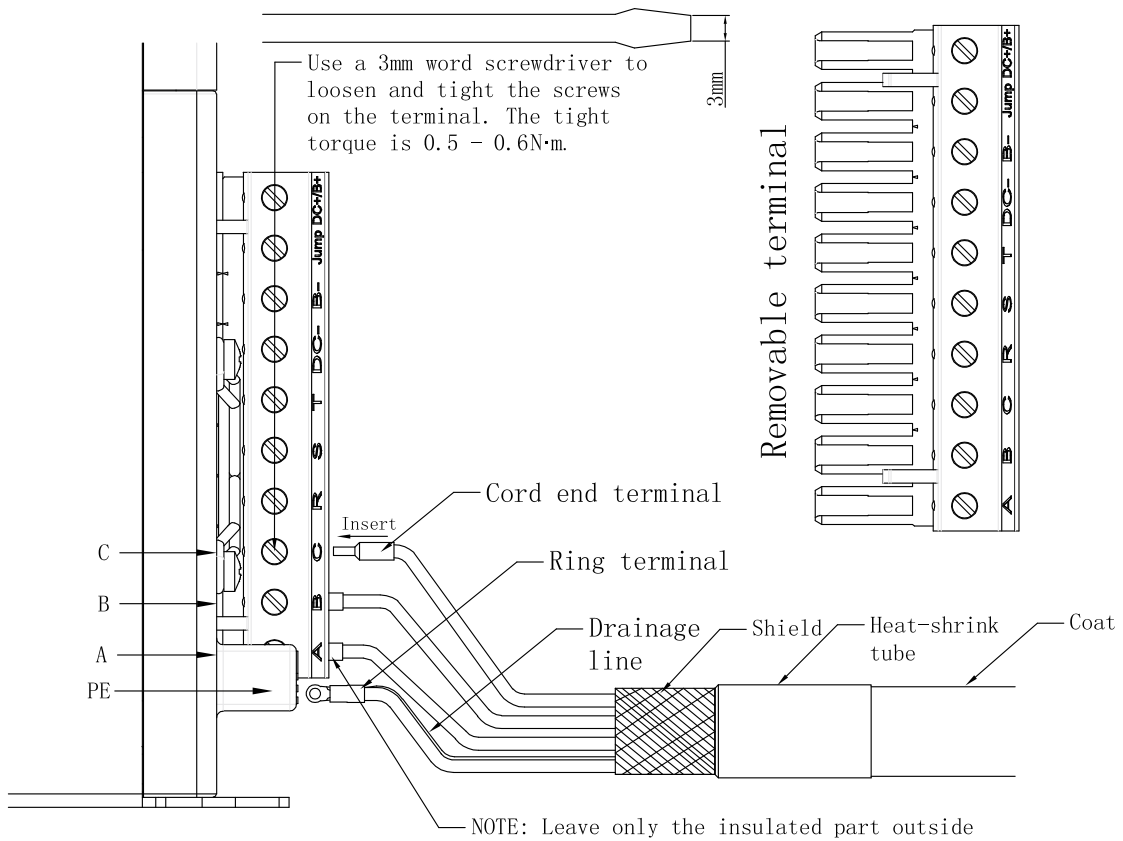

Motor Power Output Cable Installation

4.3 Control Circuit

4.3.1 Auxiliary Power Supply (AUX Power)

Auxiliary Power Supply Requirement

Main Supply	AxN 09.20.4
Voltage	24V
Type	DC power
Fluctuation of Voltage	±15% (22.8 ~ 25.2V)
Nominal Power	48W
Nominal Current	2A

Port Location

AxN 09.20.4 Drive's Auxiliary Power Supply Port (Female Plug, 4Pin) is on the top of the drive. And a corresponding Auxiliary Power Supply Terminal (Male Plug, 4Pin) is provided in the accessories. Refer to the following figure for exact locations.

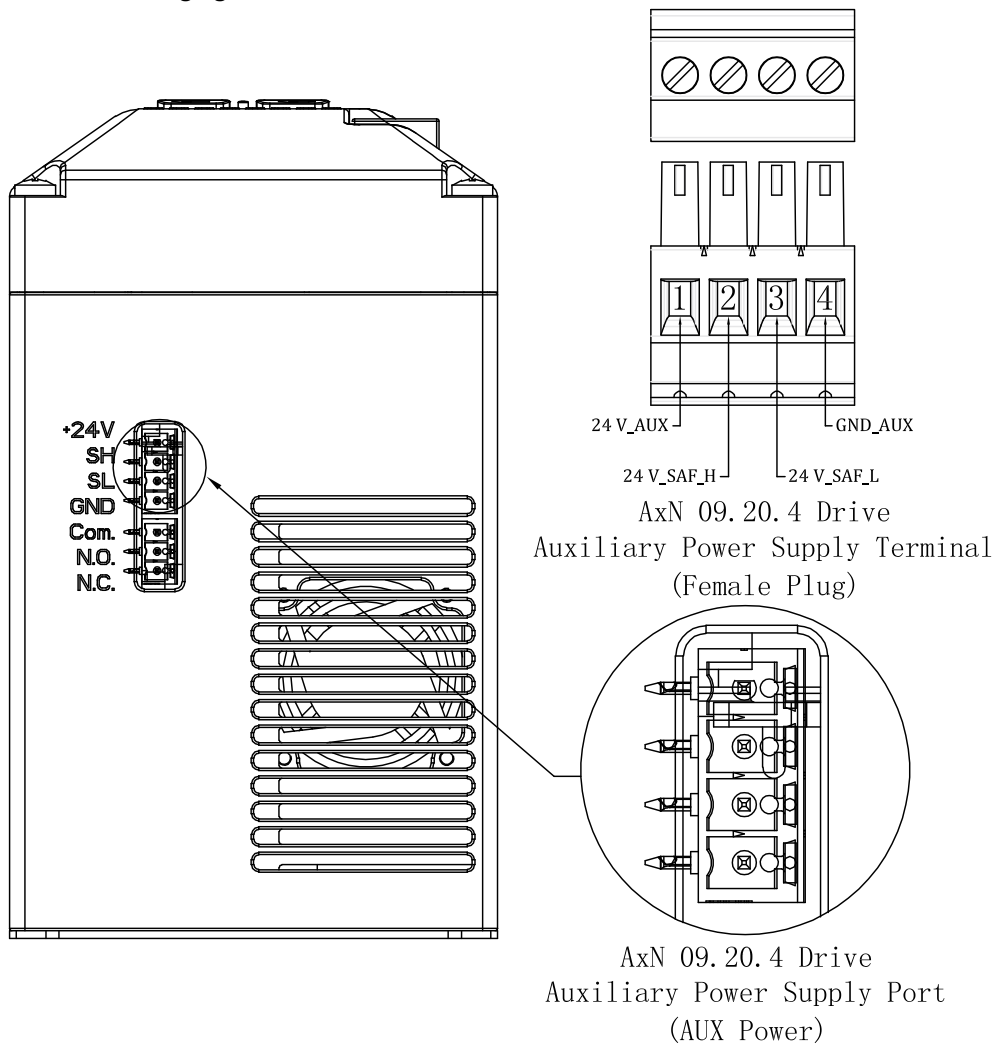

Auxiliary Power Supply Port

Terminal Configuration

Pin	Name	Function	Description
1	24V_AUX	Control circuit power supply	24Vdc Positive
2	24V_SAF_H	STO high-side power bridge power supply	24Vdc Positive
3	24V_SAF_L	STO low-side power bridge power supply	24Vdc Positive
4	GND_AUX	Reference ground	24Vdc Negative

4.3.2 Safe Torque Off (STO)

STO Function

Normal version AxN 09.20.4 Drive does not have the STO function. If you want to use the STO function, you must order a STO version AxN 09.20.4 Drive. Normal version AxN 09.20.4 Drive has already internally short cut Pin 24V_AUX, 24_SAF_H and 24V_SAF_L, so that STO function is disabled.

STO Function Enable

The STO function is implemented using two redundant channels: SH and SL, each channel uses its own +24V DC power supply. Another two channels (+24V and GND) power the drive control and logic circuits. The connection diagram is shown as the following figure:

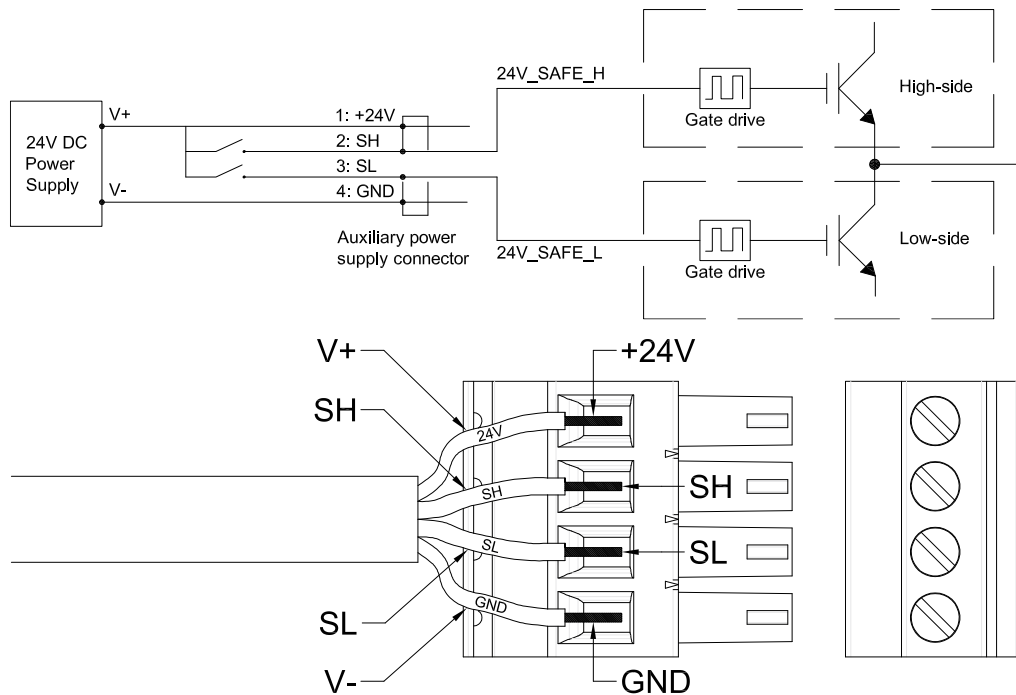

STO Function Disable

If you do not want to use Safe Torque Off function in any circumstance, you can use an insertion bridge which is attached in the accessory bag to short cut Pin 1: +24V, Pin2: SH and Pin 3: SL to disable the STO function. The connection diagram is shown as the following figure:

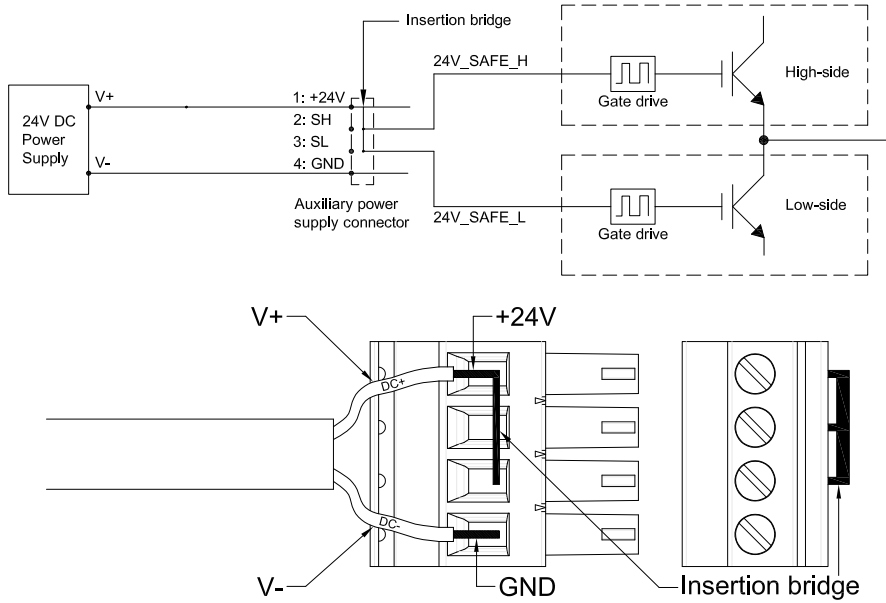

4.3.3 System Relay (R1)

Port Location

AxN 09.20.4 Drive's System Relay Port (Female Plug, 3Pin) is on the top of the drive. And a corresponding System Relay Terminal (Male Plug, 3Pin) is provided in the accessories. Refer to the following figure for exact locations.

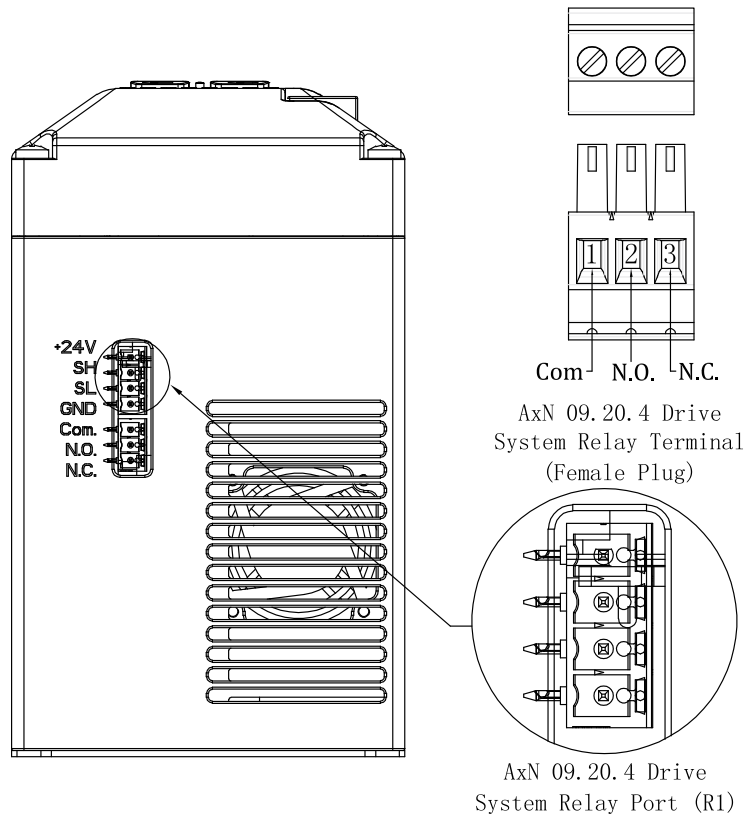

System Relay Port

Terminal Configuration

Pin	Name	Function	Description
1	Com	Common relay contact	To be used as drive system OK signal
2	N.O.	Relay normally open contact	
3	N.C.	Relay normally closed contact	

Diagram

AxN 09.20.4 Drive uses a relay to indicate the status. When Drive is power off or system is not ready, the circuit is connected between N.C. (Normally Closed) and Com. In the meantime, the circuit is disconnect between N.O. (Normally Open) and Com, illustrated as below.

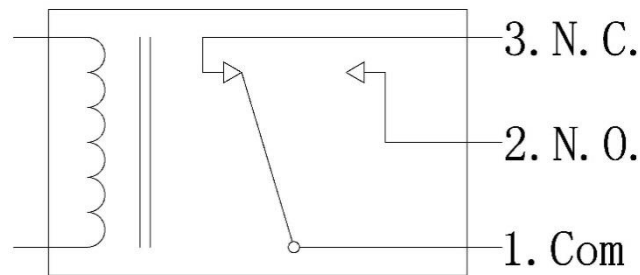

System NOT Ready

When the drive is ready, N.O. connects Com and N.C. disconnects Com, illustrated as below.

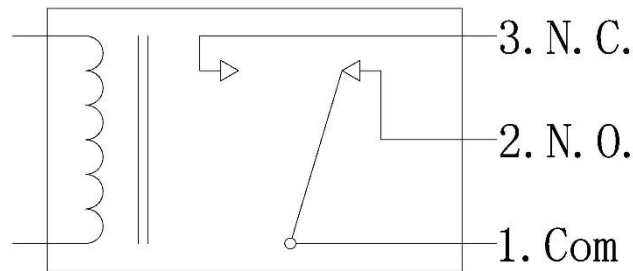

System Ready

4.4 Communication Port

4.4.1 Overview of Communication Port Panel

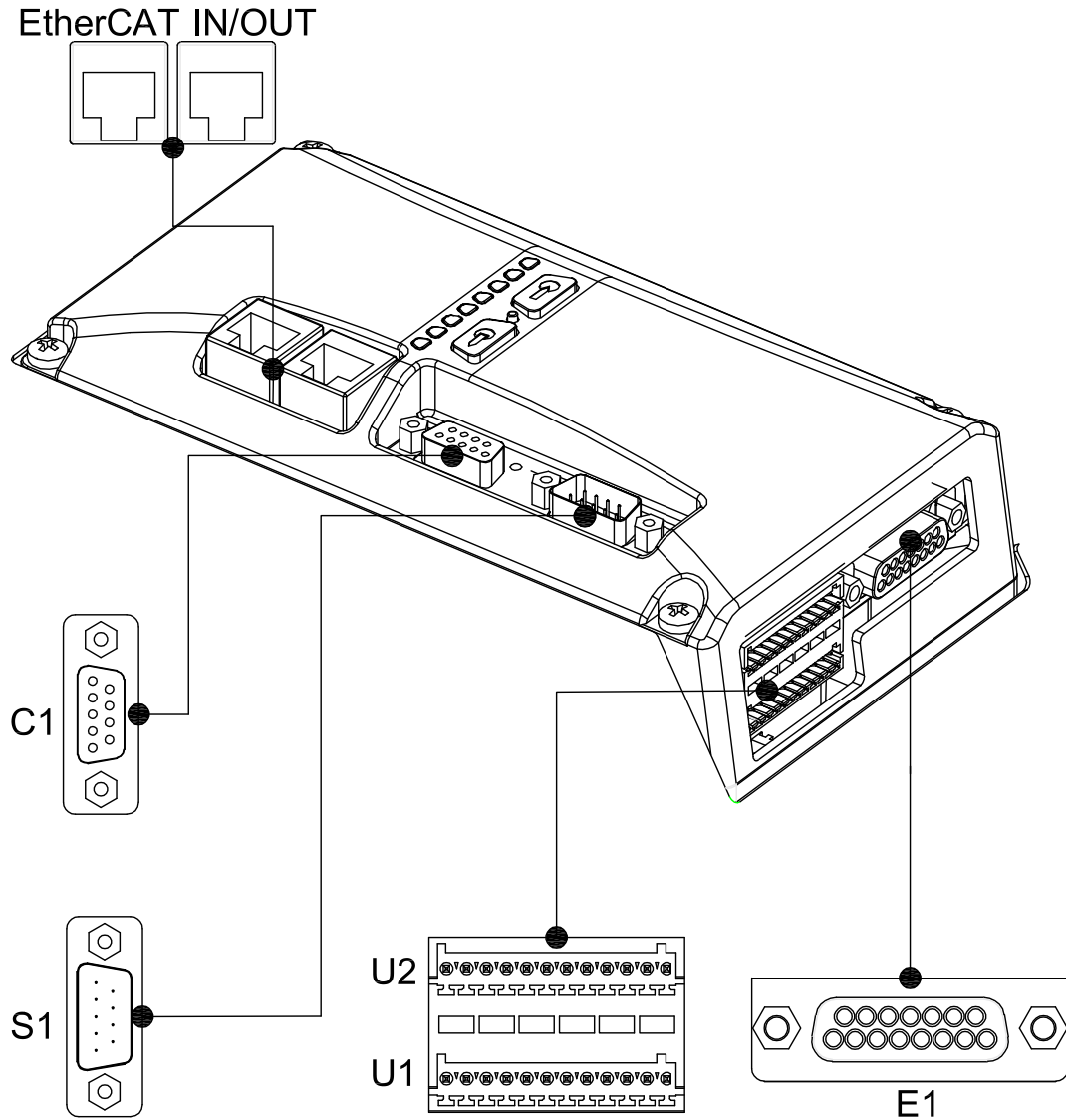

Name	Function	Description
E1	Encoder Connector	SinCos , Endat , Digital Incremental with Hall , Resolver and Hiperface
U1/U2	User Connectors	4 Analog Inputs, 2 Analog Outputs; 8 Digital Inputs, 4 Digital Outputs
S1	Serial Bus Connector	RS-232, RS-422 and RS-485 / Secondary CAN
C1	CAN Connector	Main CAN / Auxiliary Encoder
EtherCAT IN/OUT	EtherCAT Connector	RJ45 100Base-TX

4.4.2 E1 Connector——Main Encoder Port

AxN 09.20.4 Drive’s Main Encoder Port is used to connect motor’s position sensor (encoder). AxN 09.20.4 Drive can support 5 different kinds of position sensor: Sincos Encoder, Endat Encoder, Digital Incremental Encoder with Hall, Resolver and Hiperface Encoder. Different position sensor has different pin assignment, refer to correspond section for more details.

If the motor is manufactured by Phase Motion Control, our Prefabricated Encoder Cables are recommended. Refer to: [Appendix: Accessories ——5.2 Prefabricated Encoder Cable](#) for more details.

Port Location

AxN 09.20.4 Drive’s Main Encoder Port (Female Plug, 15 Pin D-Sub) is on the right bottom of the Communication Port Panel. Refer to the following figure for exact location.

AxN 09.20.4 Drive
Main Encoder Port

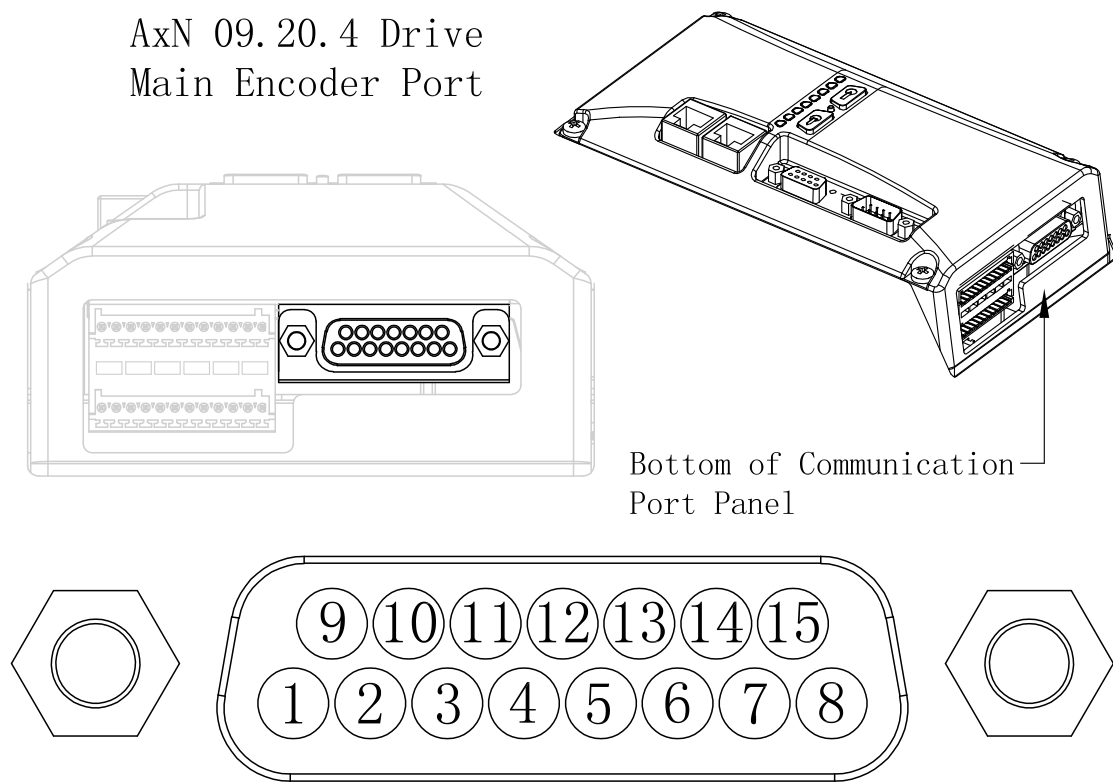

4.4.3 Sincos Encoder

Pin Assignment

Pin	Name	Function	Signal Description
1	GND	Supply ground	Encoder ground
2	SIN+	Encoder absolute channel	1 Vpp differential
3	COS+	Encoder absolute channel	1 Vpp differential
4	COS-	Encoder absolute channel	1 Vpp differential
5	SIN-	Encoder absolute channel	1 Vpp differential
6	+Vcc	Encoder supply, 5Vdc	Positive supply voltage
7	A+	Encoder incremental channel	1 Vpp differential
8	KTY+	Thermal sensor positive	
9	I-	Encoder index	1 Vpp differential
10	-----	-----	-----
11	-----	-----	-----
12	A-	Encoder incremental channel	1 Vpp differential
13	B-	Encoder incremental channel	1 Vpp differential
14	I+	Encoder index	1 Vpp differential
15	B+	Encoder Incremental channel	1 Vpp differential

Connection Table (with Ultract Series Motors)

Sincos Encoder

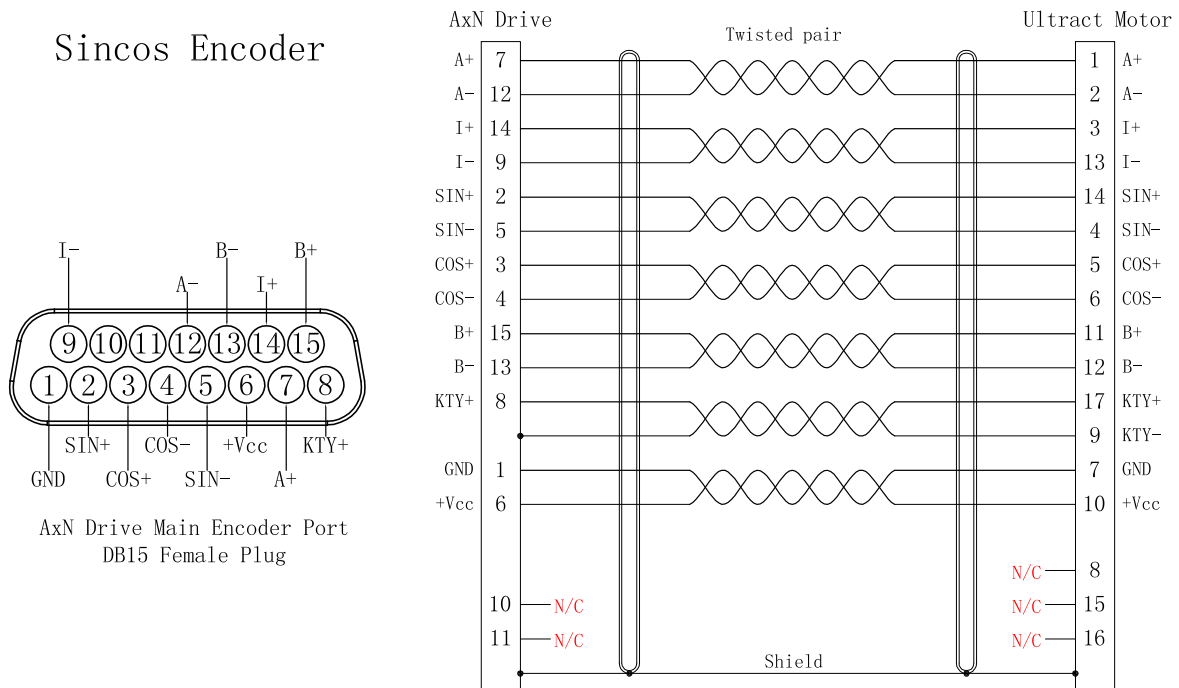

- 1) N/C — No Connection;
- 2) Connector back shell shielded 360° (Both ends);
- 3) ● means that the shield or cable should connect to connectors.

4.4.4 Endat Encoder

Pin Assignment

Pin	Name	Function	Signal Description
1	GND	Supply ground	Encoder ground
2	---	---	---
3	CLOCK+	Endat clock	TTL
4	CLOCK-	Endat clock	TTL
5	---	---	---
6	+Vcc	Encoder supply, 8Vdc	Positive supply voltage
7	---	---	---
8	KTY+	Thermal sensor positive	
9	DATA-	Endat data	TTL
10	---	---	---
11	---	---	---
12	---	---	---
13	---	---	---
14	DATA+	Endat data	TTL
15	---	---	---

Connection Table (with Ultract Series Motors)

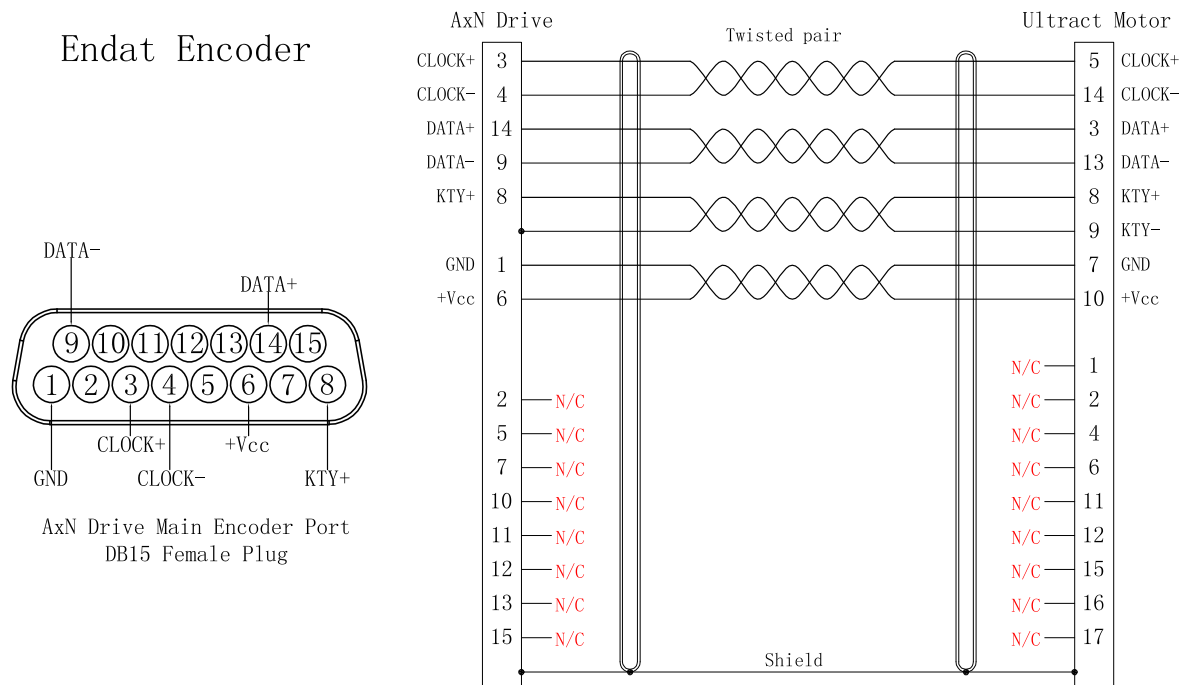

- 1) N/C — No Connection;
- 2) Connector back shell shielded 360° (Both ends);
- 3) ● means that the shield or cable should connect to connectors.

4.4.5 Digital Incremental Encoder with Hall

Pin Assignment

Pin	Name	Function	Signal Description
1	GND	Supply ground	Encoder ground
2	---	---	---
3	H1	Hall sensor	TTL
4	H2	Hall sensor	TTL
5	H3	Hall sensor	TTL
6	+Vcc	Encoder supply, 8Vdc	Positive supply voltage
7	B+	Encoder incremental channel	TTL
8	KTY+	Thermal sensor positive	
9	I-	Encoder index	TTL
10	---	---	---
11	---	---	---
12	B-	Encoder incremental channel	TTL
13	A-	Encoder incremental channel	TTL
14	I+	Encoder index	TTL
15	A+	Encoder incremental channel	TTL

Connection Table (with Ultract Series Motors)

Digital Incremental Encoder with Hall

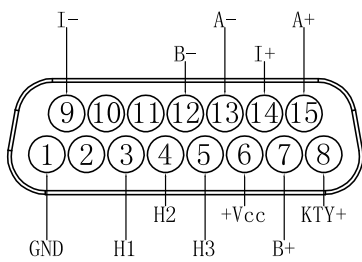

AxN Drive Main Encoder Port
DB15 Female Plug

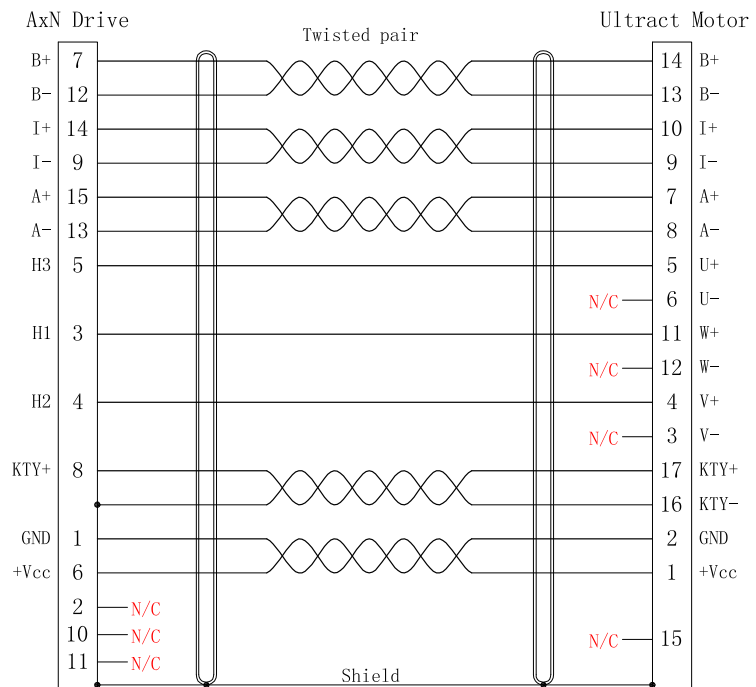

- 1) N/C — No Connection;
- 2) Connector back shell shielded 360° (Both ends);
- 3) ● means that the shield or cable should connect to connectors.

4.4.6 Resolver

Pin Assignment

Pin	Name	Function	Signal Description
1	---	---	---
2	SIN+	Absolute channel	Differential signal
3	COS+	Absolute channel	Differential signal
4	COS-	Absolute channel	Differential signal
5	SIN-	Absolute channel	Differential signal
6	---	---	---
7	---	---	---
8	KTY+	Thermal sensor positive	
9	---	---	---
10	RESEX+	Resolver energising +	8kHz sinusoidal wave
11	RESEX-	Resolver energising -	8kHz sinusoidal wave
12	---	---	---
13	---	---	---
14	---	---	---
15	---	---	---

Connection Table (with Ultract Series Motors)

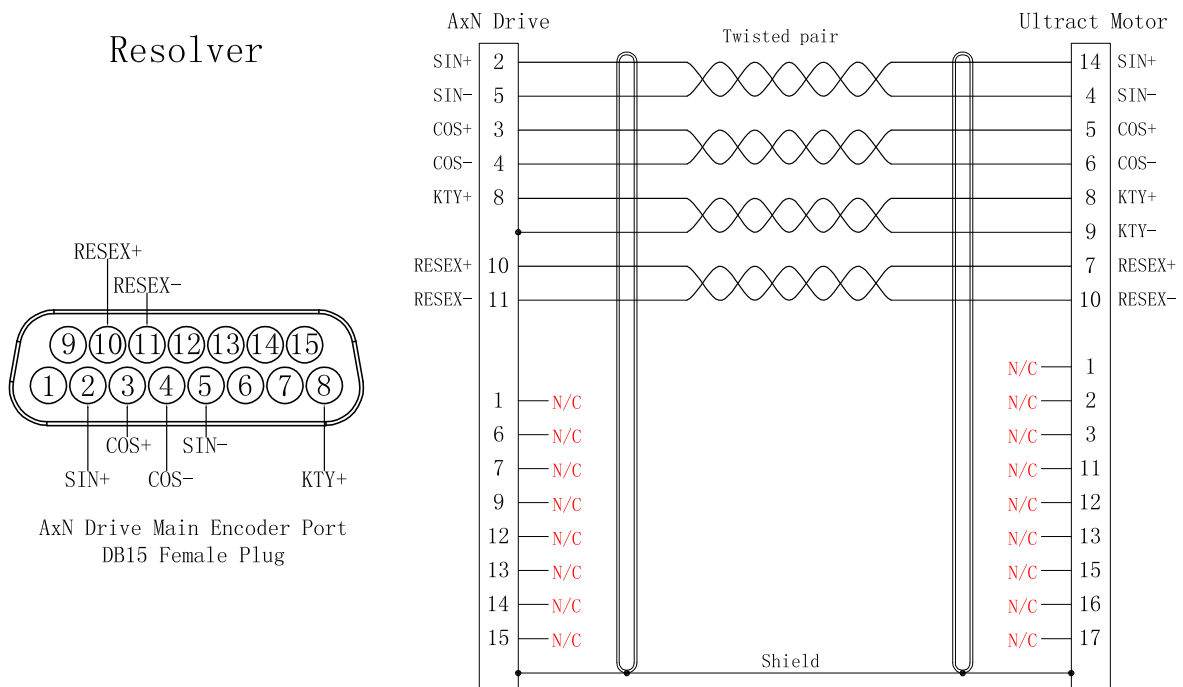

- 1) N/C — No Connection;
- 2) Connector back shell shielded 360° (Both ends);
- 3) ● means that the shield or cable should connect to connectors.

4.4.7 Hiperface Encoder

Pin Assignment

Pin	Name	Function	Signal Description
1	GND	Supply ground	Encoder ground
2	----	----	----
3	----	----	----
4	----	----	----
5	----	----	----
6	+Vcc	Encoder supply, 8Vdc	Positive supply voltage
7	COS+	Process data channel	TTL
8	KTY+	Thermal sensor positive	
9	DATA-	RS-485 parameter channel	TTL
10	----	----	----
11	----	----	----
12	COS-	Process data channel	TTL
13	SIN-	Process data channel	TTL
14	DATA+	RS-485 parameter channel	TTL
15	SIN+	Process data channel	TTL

Connection Table (with Ultract Series Motors)

Hiperface Encoder

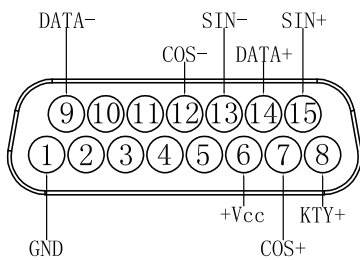

AxN Drive Main Encoder Port
DB15 Female Plug

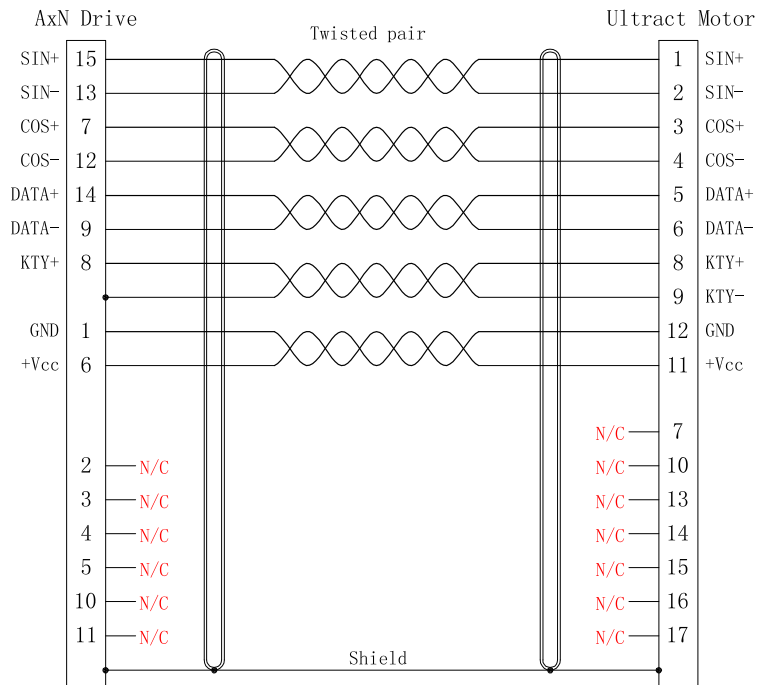

- 1) N/C — No Connection;
- 2) Connector back shell shielded 360° (Both ends);
- 3) ● means that the shield or cable should connect to connectors.

4.4.8 S1 Connector——Serial Bus Port

AxN 09.20.4 Drive’s Serial Bus Port (S1) supports RS-232, RS-422, RS-485 and CAN protocol. But only one communication interface can be used at a time.

Port Location

AxN 09.20.4 Drive’s Serial Bus Port (Male Plug, 9 Pin D-Sub) is on the downside of drive’s communication port panel. Refer to the following figures for exact location.

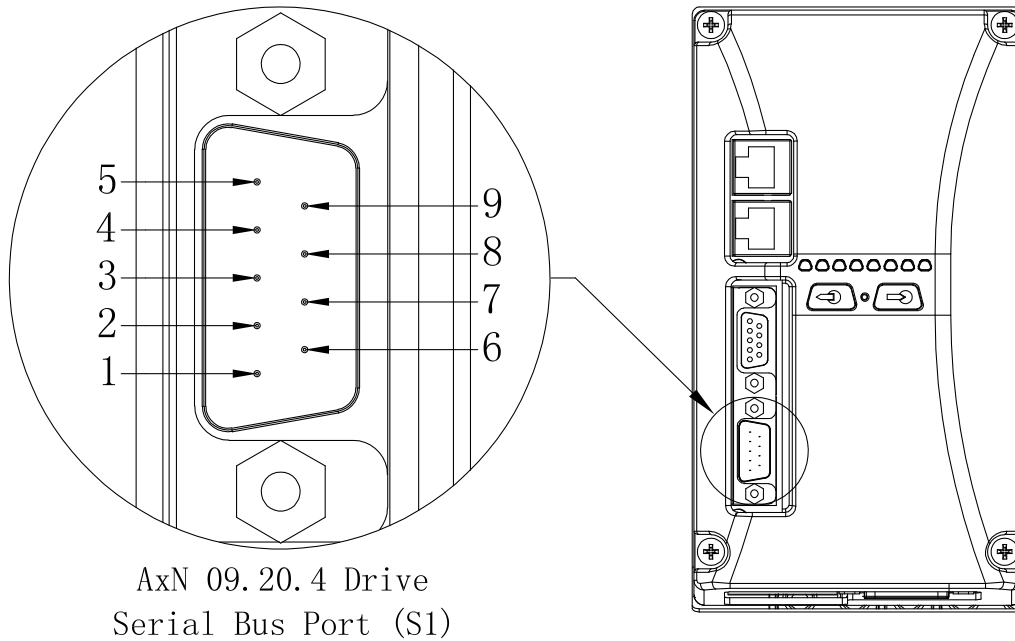

4.4.9 RS-232

Pin Assignment

Pin	Standard RS-232	AxN RS-232	Function
1	DCD	---	Data Carrier Detect
2	RXD	RXD	Received Data
3	TXD	TXD	Transmitted Data
4	DTR	DTR	Data Terminal Ready
5	GND	GND	Common Ground
6	DSR	DSR	Data Set Ready
7	RTS	RTS	Request To Send
8	CTS	CTS	Clear To Send
9	RI	---	Ring Indicator

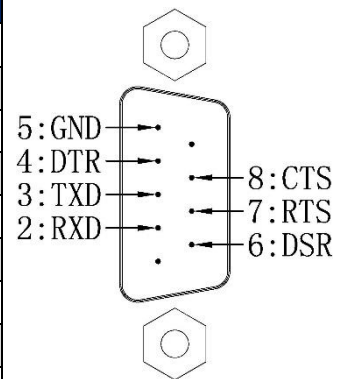

Notes:

- RS-232 devices may be classified as Data Terminal Equipment (DTE) or Data Communication Equipment (DCE); this defines at each device which wires will be sending and receiving each signal. AxN 09.20.4 Drive is a Data Communication Equipment (DCE), and a controller or a computer is a Data Terminal Equipment (DTE).

2. The signal voltage is $\pm 12V$, and the max current of DTR (Pin4) is 100mA.

Minimal "3-wire" Connection

A minimal "3-wire" RS-232 connection consisting only of transmit data, receive data, and ground, is commonly used when the full facilities of RS-232 are not required. And it is also the minimal connection requirement of Cockpit communication with AxN 09.20.4 Drive.

Connection table

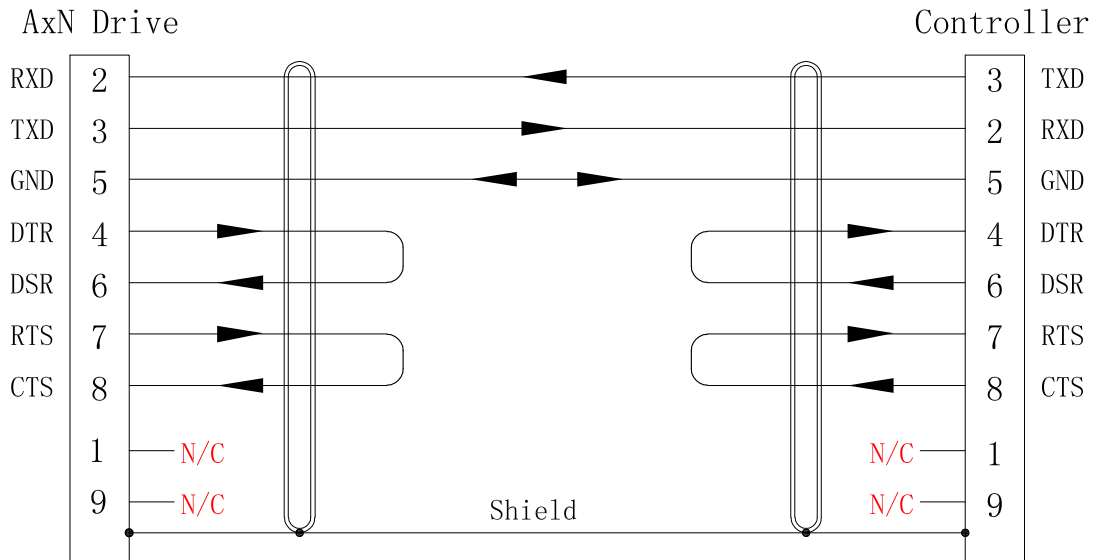

- 1) N/C—No Connection;
- 2) Connector back shell shielded 360° (Both ends);
- 3) ● means that the shield or cable should connect to connectors.

Connection diagram

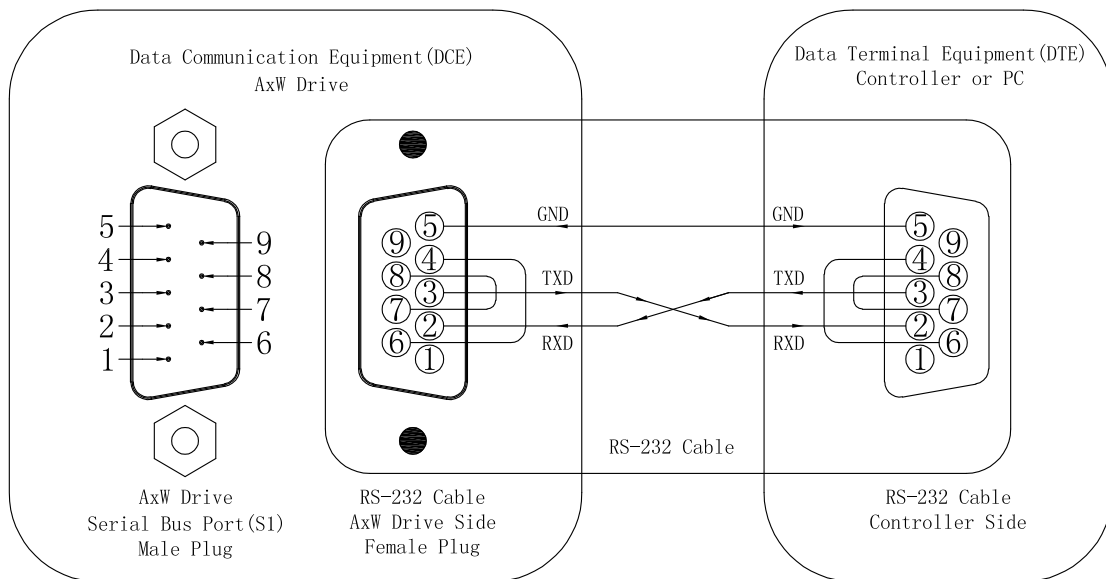

Maximal "7-wire" Connection

When the controller has full facilities of RS-232, "7-wire" connection is the maximal connection which AxN 09.20.4 drive can support.

NOTE: Do **NOT** use "9-wire" connection, AxN 09.20.4 drive does not support DCD and RI function.

Connection table

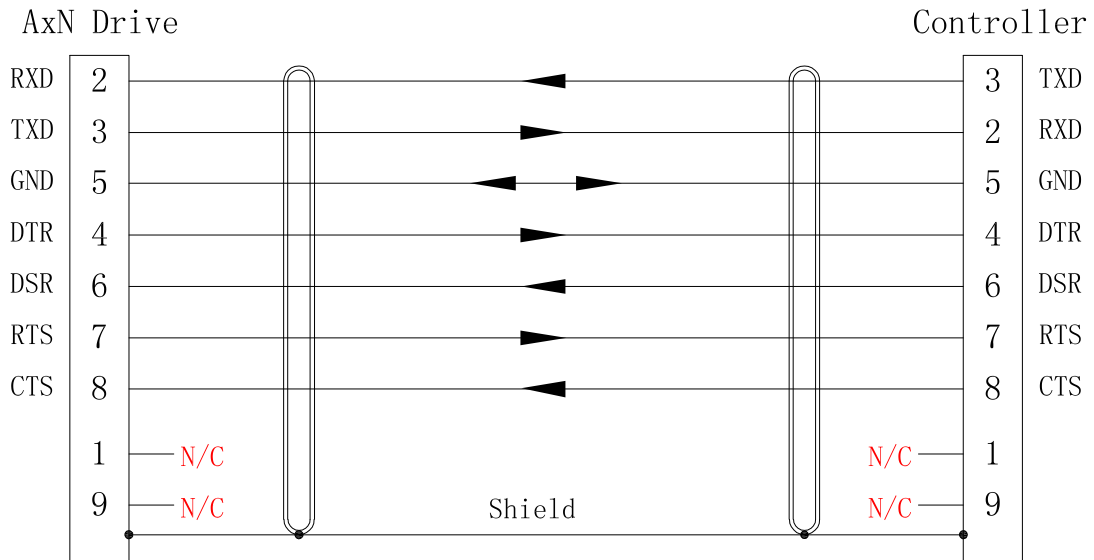

- 1) N/C — No Connection;
- 2) Connector back shell shielded 360° (Both ends);
- 3) ● means that the shield or cable should connect to connectors.

Connection diagram

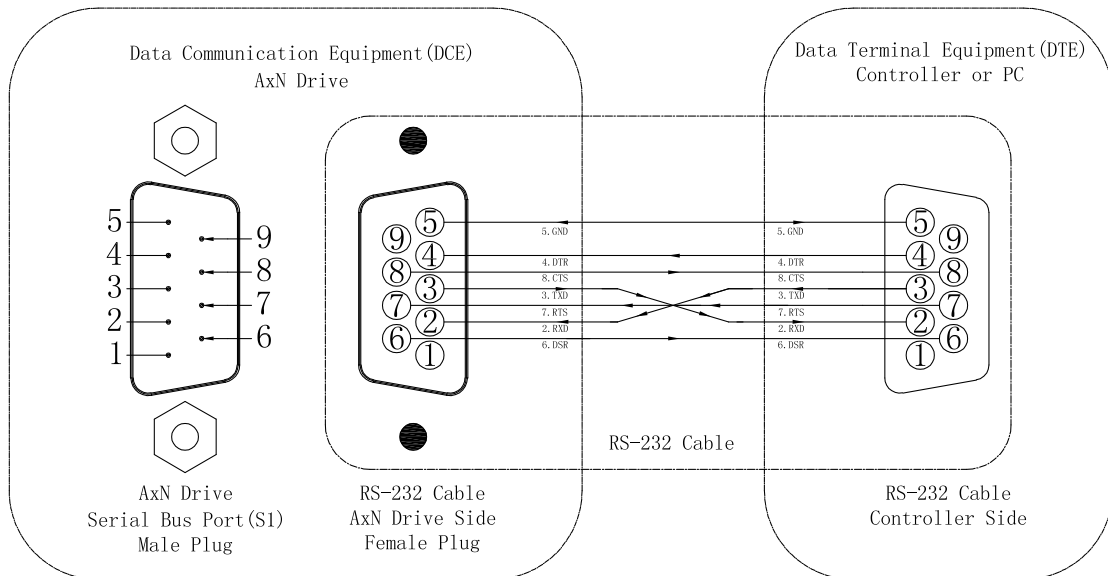

4.4.10 RS-422/RS-485

Pin Assignment

Pin	RS-422	RS-485	Function
1	TX+	TX+(LN+)	Transmit Data +
2	TX-	TX-(LN-)	Transmit Data -
3	RX+	RX+(LN+)	Receive Data +
4	RX-	RX-(LN-)	Receive Data -
5	GND	GND	Ground
6	---	---	---
7	---	---	---
8	---	---	---
9	---	---	---

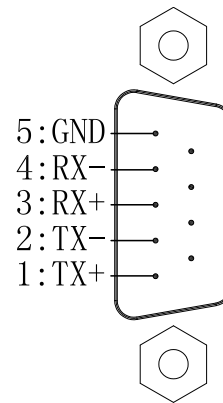

RS-422 Connection Table

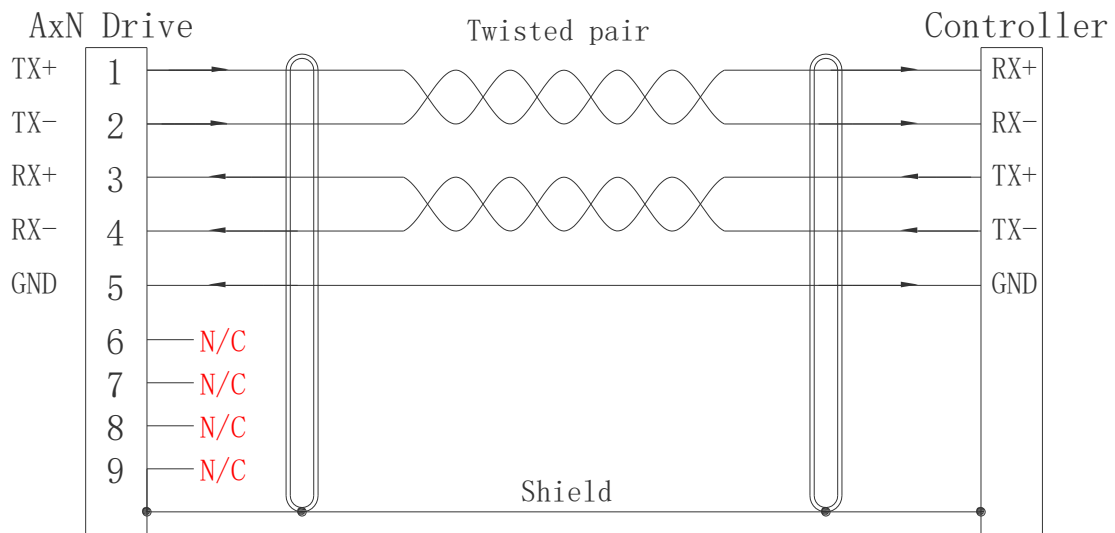

RS-485 Connection Table

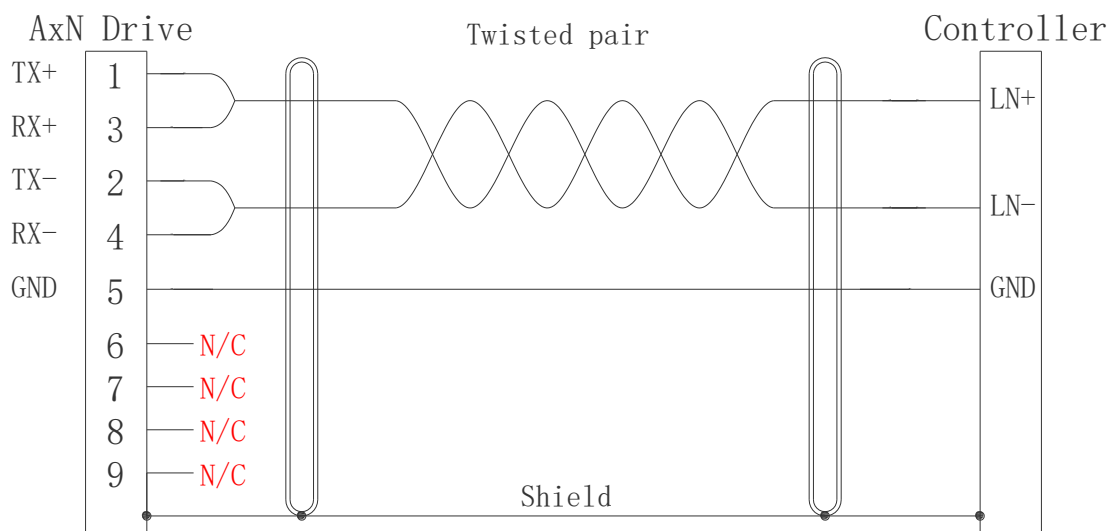

- 1) N/C — No Connection;
- 2) Connector back shell shielded 360° (Both ends);
- 3) ● means that the shield or cable should connect to connectors.

4.4.11 Auxiliary CAN

AxN 09.20.4 Drive supports CANOpen protocol and it has two independent CAN access. The auxiliary CAN controller links to the S1 connector.

Pin Assignment

Pin	CANOpen	Function
1	CAN_H	CAN_H bus line (dominant high)
2	---	---
3	---	---
4	---	---
5	GND	Ground connection
6	---	---
7	---	---
8	---	---
9	CAN_L	CAN_L bus line (dominant low)

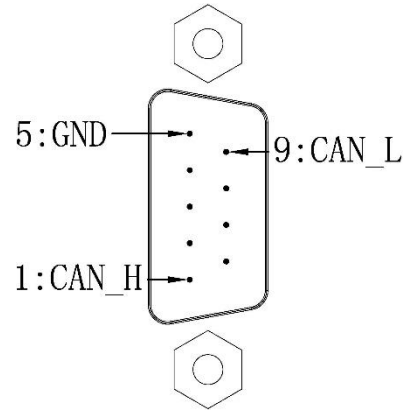

Note: CANOpen pin assignment on S1 connector does NOT meet CiA 102 Standard.

Connection Table

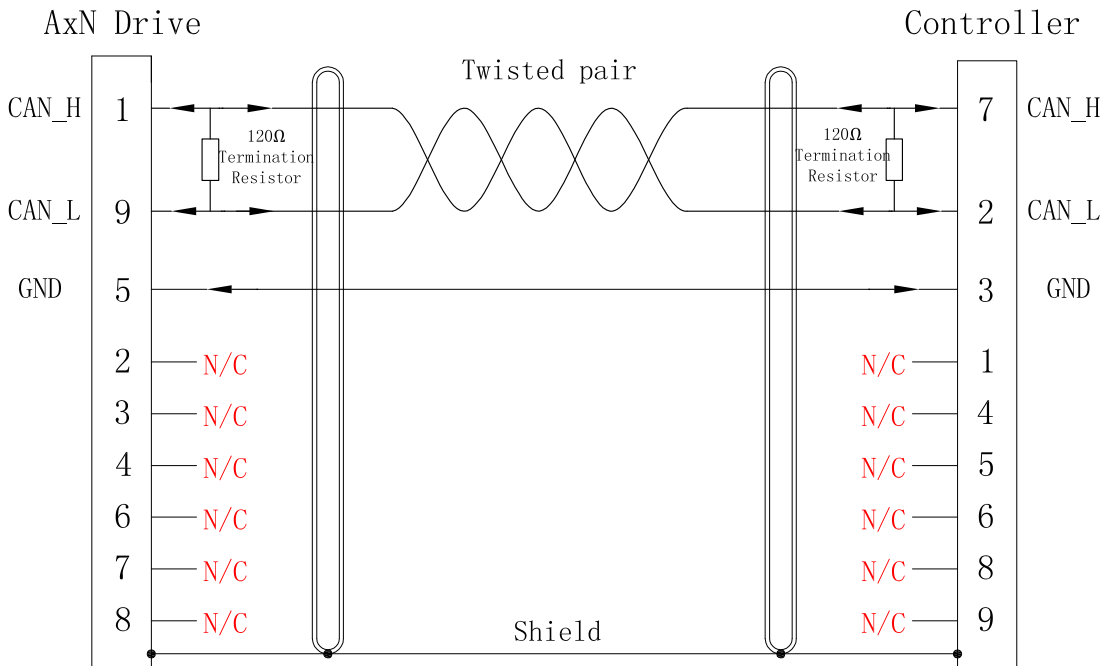

- 1) N/C — No Connection;
- 2) Connector back shell shielded 360° (Both ends);
- 3) ● means that the shield or cable should connect to connectors.

Connection diagram

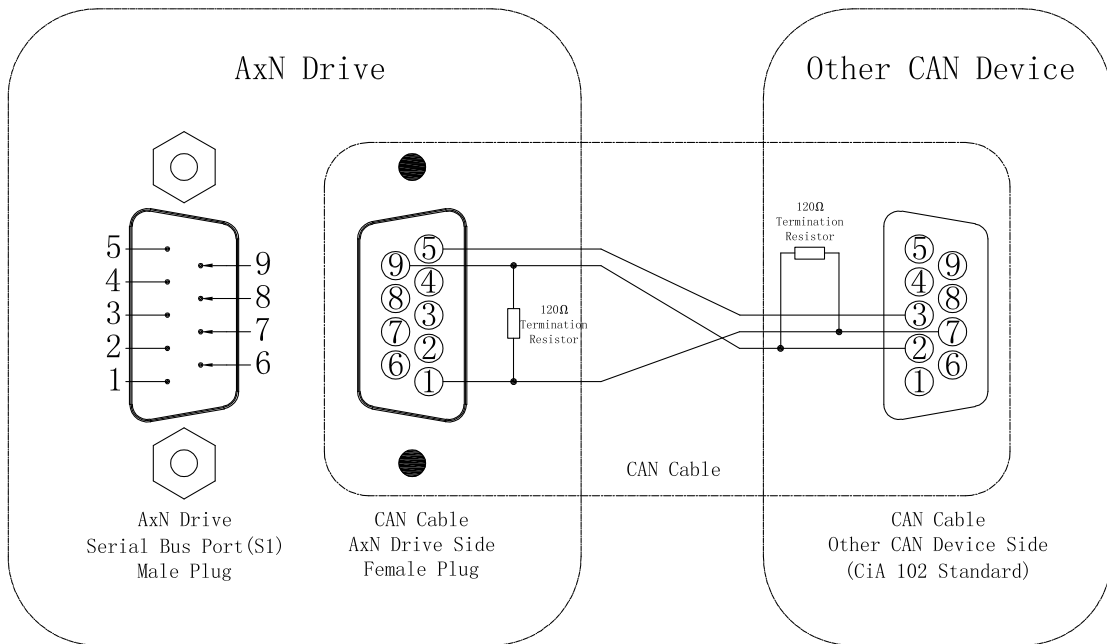

Note: Only the first and the last CAN node device should use a 120Ω terminal resistor.

4.4.12 C1 Connector——Main CAN Port

AxN 09.20.4 Drive’s Main CAN Port (C1) connects to the main CAN controller inside the AxN drive. It is the default CAN network port of AxN drive. Moreover, C1 port can also be used as Auxiliary Encoder Port.

Port Location

AxN 09.20.4 Drive’s Main CAN Port (Female Plug, 9 Pin D-Sub) is on the middle side of drive’s communication port panel. Refer to the following figures for exact location.

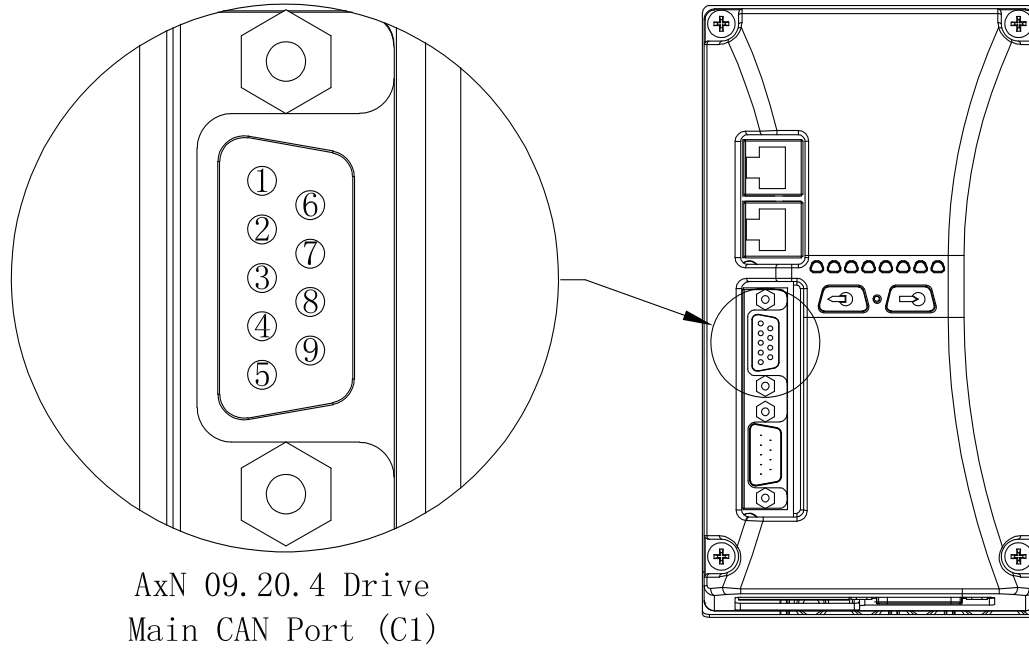

4.4.13 Main CAN

AxN 09.20.4 Drive supports CANOpen protocol and it has two independent CAN access. The main CAN controller links to the C1 connector.

Pin Assignment

Pin	CANOpen	Function
1	---	---
2	CAN_L	CAN_L bus line (dominant low)
3	GND	Ground connection
4	---	---
5	---	---
6	---	---
7	CAN_H	CAN_H bus line (dominant high)
8	---	---
9	---	---

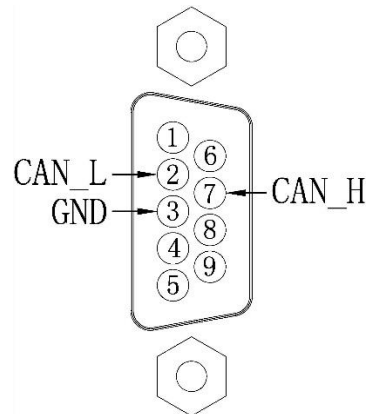

Connection Table

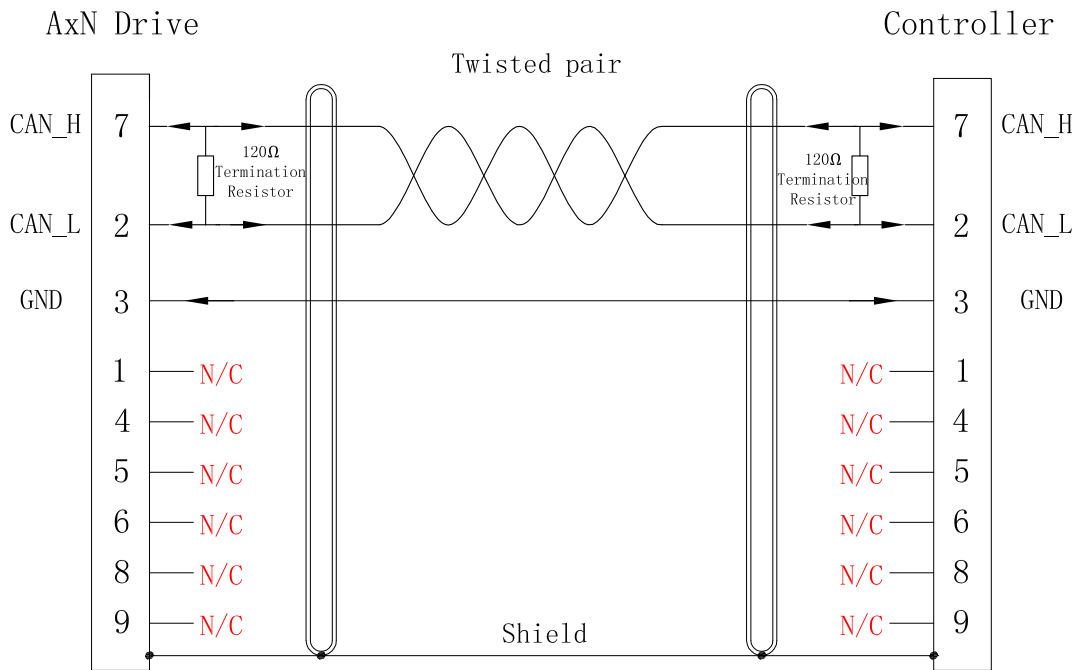

- 1) N/C—No Connection;
- 2) Connector back shell shielded 360° (Both ends);
- 3) ● means that the shield or cable should connect to connectors.

Connection diagram

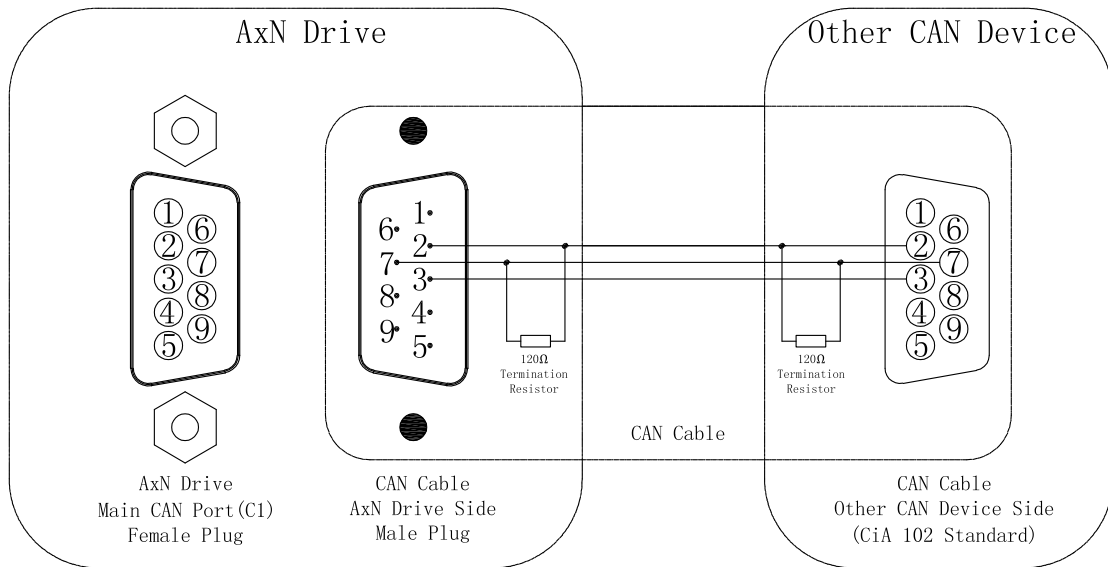

Note: Only the first and the last CAN node device should use a 120Ω terminal resistor.

4.4.14 Auxiliary Encoder

C1 port is also the Auxiliary Encoder Port. It supports Endat Encoder IN, Incremental Encoder IN and Simulated Incremental Encoder OUT. The output voltage of Simulated Incremental Encoder is 0 ~ 3.3V.

Endat Encoder (IN)

Pin	Name	Function
1	DATA+	Endat Data
2	---	---
3	GND	Ground connection
4	CLOCK-	Endat Clock
5	---	---
6	DATA-	Endat Data
7	---	---
8	CLOCK+	Endat Clock
9	---	---

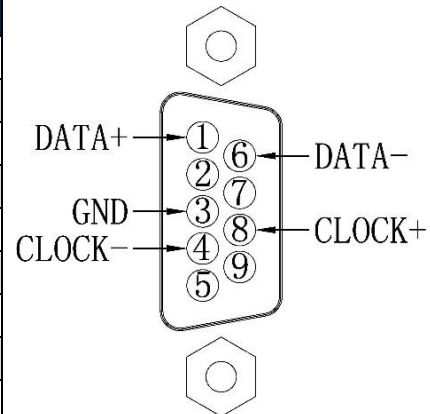

Incremental Encoder (IN/OUT)

Pin	Name	Function
1	B+	Encoder incremental channel
2	---	---
3	GND	Ground connection
4	A-	Encoder incremental channel
5	I-	Encoder index
6	B-	Encoder incremental channel
7	---	---
8	A+	Encoder incremental channel
9	I+	Encoder index

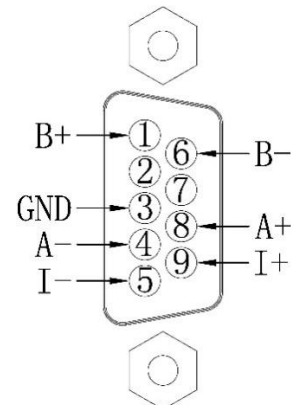

4.4.15 EtherCAT IN/OUT——EtherCAT Port

AxN 09.20.4 Drive supports EtherCAT fieldbus protocol. And it can be connected to an EtherCAT network through two connectors: EtherCAT IN and EtherCAT OUT.

Port Location

AxN 09.20.4 Drive's EtherCAT Port is on the upside of drive's communication port panel, formed by two RJ45 100Base-TX female plug. Refer to the following figure for exact location.

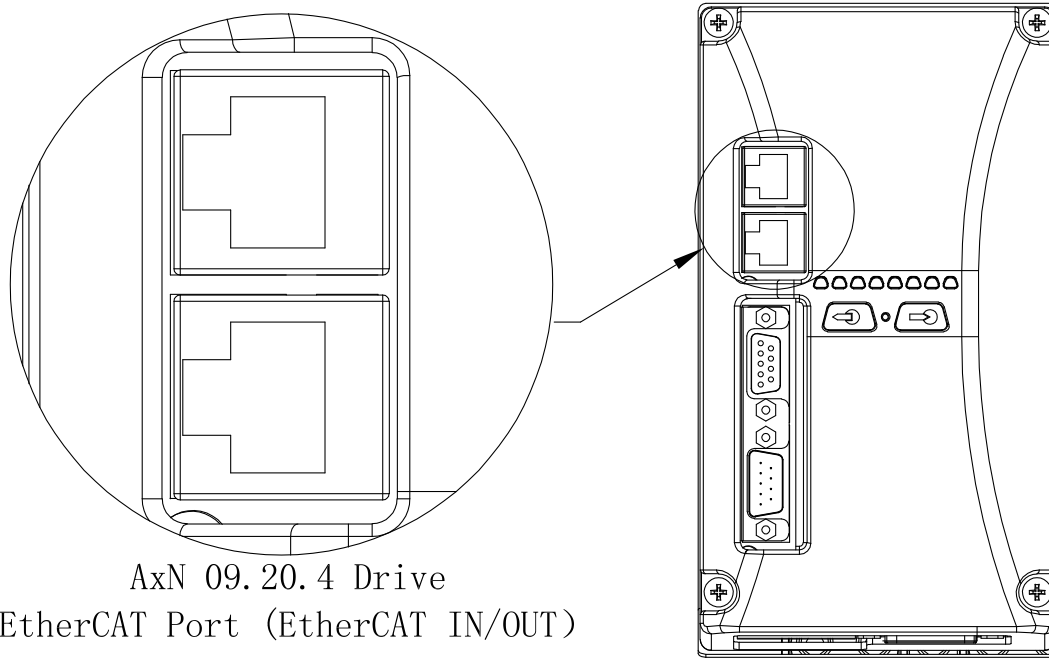

Pin Assignment

Pin	Name	Function
1	TX +	Transmit Data +
2	TX -	Transmit Data -
3	RX +	Receive Data +
4	---	---
5	---	---
6	RX -	Receive Data -
7	---	---
8	---	---

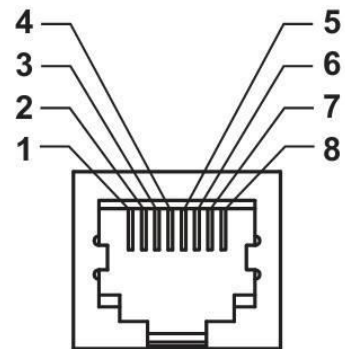

4.4.16 U1/U2—User Connectors

Port Location

AxN 09.20.4 Drive's User Connectors (Male Plug, 2×12 pin) are on the left bottom of the Communication Port Panel. Refer to the following figure for exact location.

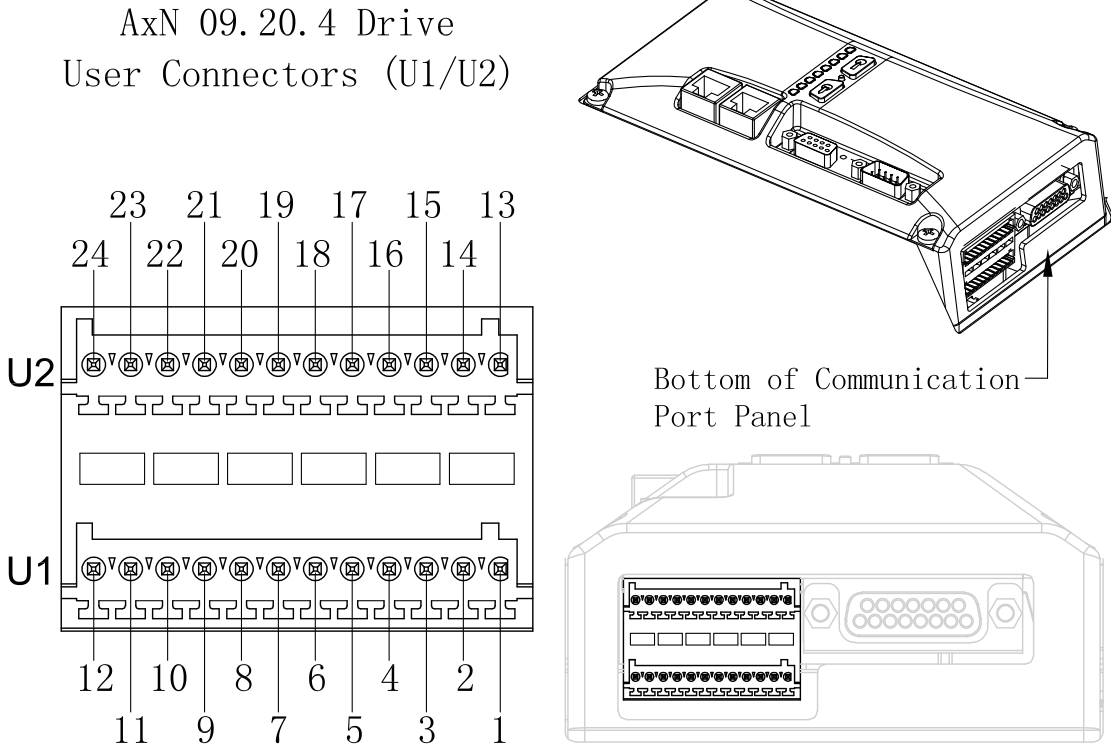

Diagram

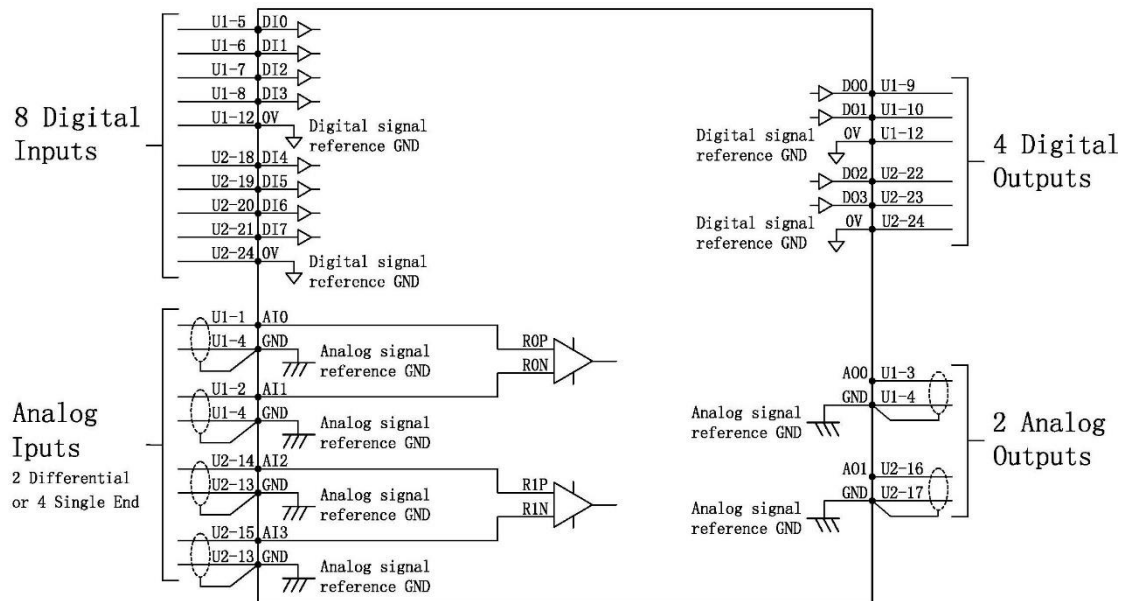

NOTE: All analog signal reference GND are the same, and all digital signal reference GND are the same.

Pin Assignment

User Connector U1

Pin	Name	Function	Signal Description
1	R0P (AI0)	Programmable analog input	$\pm 10V$, $Z_{in}=10K\Omega$, able to switch between differential mode and single end mode ⁽¹⁾
2	R0N (AI1)	Programmable analog input	$\pm 10V$, $Z_{in}=10K\Omega$, able to switch between differential mode and single end mode ⁽¹⁾
3	A00	Programmable analog output	0 ~ 10V f.s., 30 mA
4	GND	Analog reference ground	Analog signals reference
5	DI0	Programmable digital input	6.6 k Ω to ground, 20-30 V
6	DI1	Programmable digital input	6.6 k Ω to ground, 20-30 V
7	DI2	Programmable digital input	6.6 k Ω to ground, 20-30 V
8	DI3	Programmable digital input	6.6 k Ω to ground, 20-30 V
9	DO0	Programmable digital output	PNP open collector, 24 V, 100mA max
10	DO1	Programmable digital output	PNP open collector, 24 V, 100mA max
11	N/C	---	---
12	COM	Digital reference ground	Digital signal reference

User Connector U2

Pin	Name	Function	Signal Description
13	GND	Analog reference ground	Analog signals reference
14	R1P (AI2)	Programmable analog input	$\pm 10V$, $Z_{in}=10K\Omega$, able to switch between differential mode and single end mode ⁽¹⁾
15	R1N (AI3)	Programmable analog input	$\pm 10V$, $Z_{in}=10K\Omega$, able to switch between differential mode and single end mode ⁽¹⁾
16	A01	Programmable analog output	0 ~ 10V f.s., 30 mA
17	GND	Analog reference ground	Analog signals reference
18	DI4	Programmable digital input	6.6 k Ω to ground, 20-30 V
19	DI5	Programmable digital input	6.6 k Ω to ground, 20-30 V
20	DI6	Programmable digital input	6.6 k Ω to ground, 20-30 V
21	DI7	Programmable digital input	6.6 k Ω to ground, 20-30 V
22	DO2	Programmable digital output	PNP open collector, 24 V, 100mA max
23	DO3	Programmable digital output	PNP open collector, 24 V, 100mA max
24	0V	Auxiliary supply negative	Digital signal reference

Notes:

1. AxN 09.20.4 Drive has 4 single end analog inputs or 2 differential analog inputs, and they can be switched by software. The default mode is differential mode. When analog inputs are in differential mode, pin R0P (U1-1) and pin R0N (U1-2) map the R0 channel in software, and pin R1P (U2-14) and pin R1N (U2-15) map the R1 channel in software. On the other hand, when analog inputs are in single end mode, pins: AI0 (U1-1), AI1 (U1-2), AI2 (U2-14) and AI3 (U2-15) respectively map channels AI0, AI1, AI2 and AI3 in software.

5 APPENDIX: ACCESSORIES

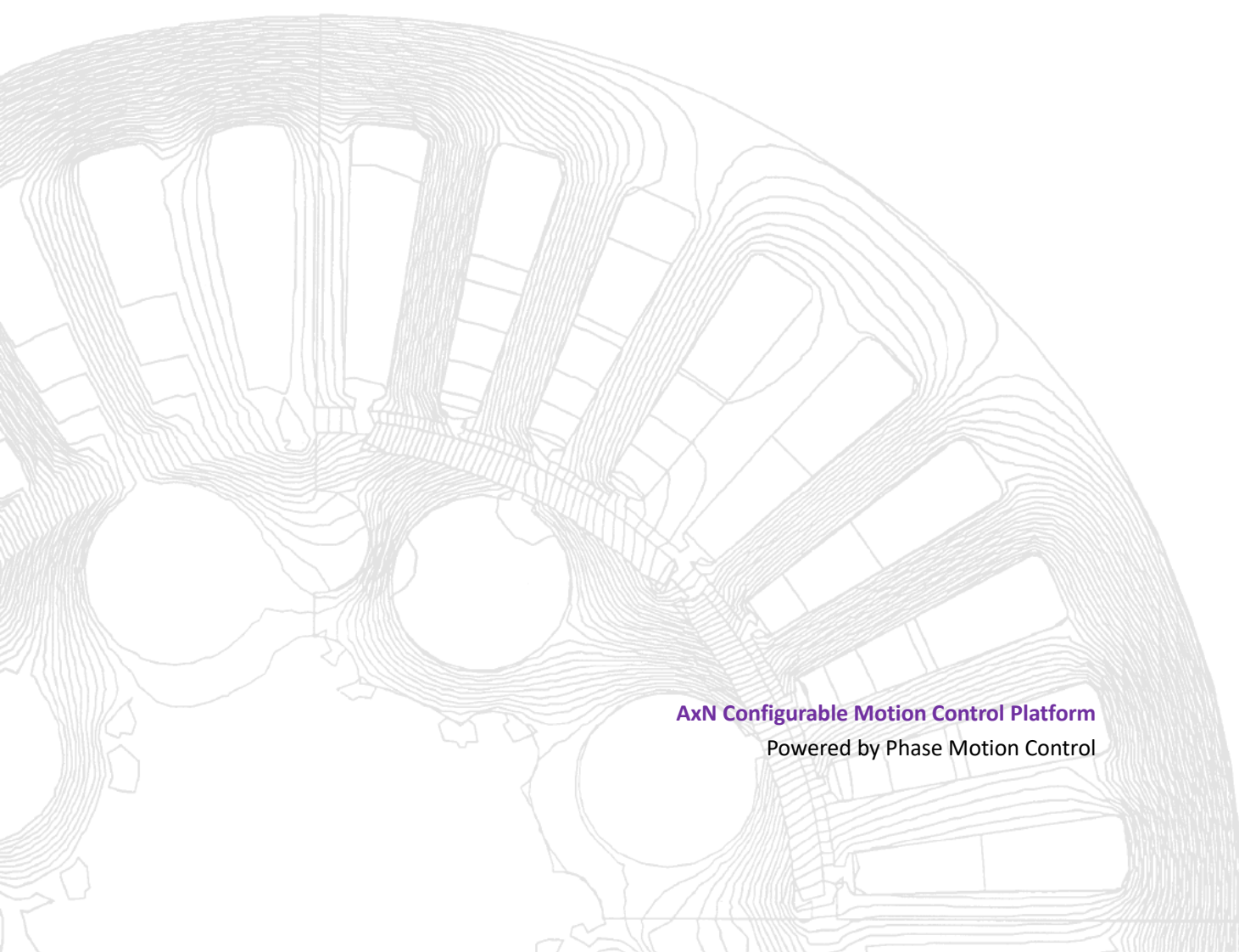

5.1 Prefabricated Motor Power Output Cable

Order Code Definition

The Order Code can provide all the necessary specifications about a Prefabricated Motor Power Output Cable. Choose the specifications and use the corresponding order cable to order.

Order Code	PW	-C	-D16	-5	-GTV
Cable Type	Power Cable				
Terminal Type	Motor Side/Drive Side C = Ring terminal/Cord end terminal F = Ring terminal/Ring terminal S = Stripped wires/Cord end terminal R = Stripped wires/Ring terminal A = Aviation plug/Cord end terminal				
Wire Gauge ⁽¹⁾	D1.5=4×1.5mm ² D2.5=4×2.5mm ² D04 =4×4mm ² D06 =4×6mm ² D10 =4×10mm ² D16 =4×16mm ² D25 =4×25mm ²	B1.5=4×1.5mm ² +2×__mm ² B2.5=4×2.5mm ² +2×__mm ² B04 =4×4mm ² +2×__mm ² B06 =4×6mm ² +2×__mm ² B10 =4×10mm ² +2×__mm ² B16 =4×16mm ² +2×__mm ² B25 =4×25mm ² +2×__mm ²			
Length	3=3m 5=5m 7=7m X ⁽²⁾ =X m				
Shield Type	G = General shielded	I = General + Internal shielded	N = No shield		
Trace Chain or Not	S = Standard	T = Trace chain			
Coat material	V=PVC	U=PUR ⁽³⁾			

Notes:

1. B in the Wire Gauge means power cable for motor with brake, the gauge of brake wires should be provided either;
2. Cable Length are not just 3m, 5m and 7m, order whatever cable length you want;
3. Cable Coat made by PUR is oil resistant and wear resistant.

Example

Order Code: PW-C-D16-7-GTV

Power cable; terminal type of motor side is ring terminal, terminal type of drive side is cord end terminal; wire gauge is 4×16mm²; length is 7m; general shielded; trace chain; insulating layer material is PVC.

5.2 Prefabricated Encoder Cable (for Phase Motors)

Order Code Definition

The Order Code can provide all the necessary specifications about a Prefabricated Encoder Cable. Choose the specifications and use the corresponding order cable to order.

Order Code	CE	-X	-A28	-5	-ISU	-xx
Cable Type	CN = Endat Encoder (EQN1325/ECN1313) CE = Endat Encoder (ECI1319/EQI1331) CS = Sincos Encoder CR = Resolver CH = Incremental with Hall sensor					
Terminal Type	X=Aviation plug / DB15(180°outlet) Y=Aviation plug/DB15(45°outlet)					
Wire Gauge ⁽¹⁾	A28=AWG28					
Length	3=3m 5=5m 7=7m X ⁽²⁾ =X m					
Shield Type	G = General shielded I = General + Internal shielded N = No shield					
Trace Chain or Not	S = Standard T = Trace chain					
Coat material	V=PVC U=PUR ⁽³⁾					
Reserve Code	Reserve					

Example

Order Code: CE-X-A28-5-ISU

Endat cable(ECI1319/EQI1331); terminal type of motor side is aviation plug, terminal type of drive side is DB15 connector(180 °outlet); internal diameter is AWG28; length 5m; general and internal shielded; standard, not trace chain; insulating layer material is PUR.

5.3 Cable Support

AxN 09.20.4 drive metal cable support is connected with the shell after the installation is completed. Large area of the metal plate can ensure that the cable shield is effectively grounded and the grounding impedance is reduced.

Overall Dimensions

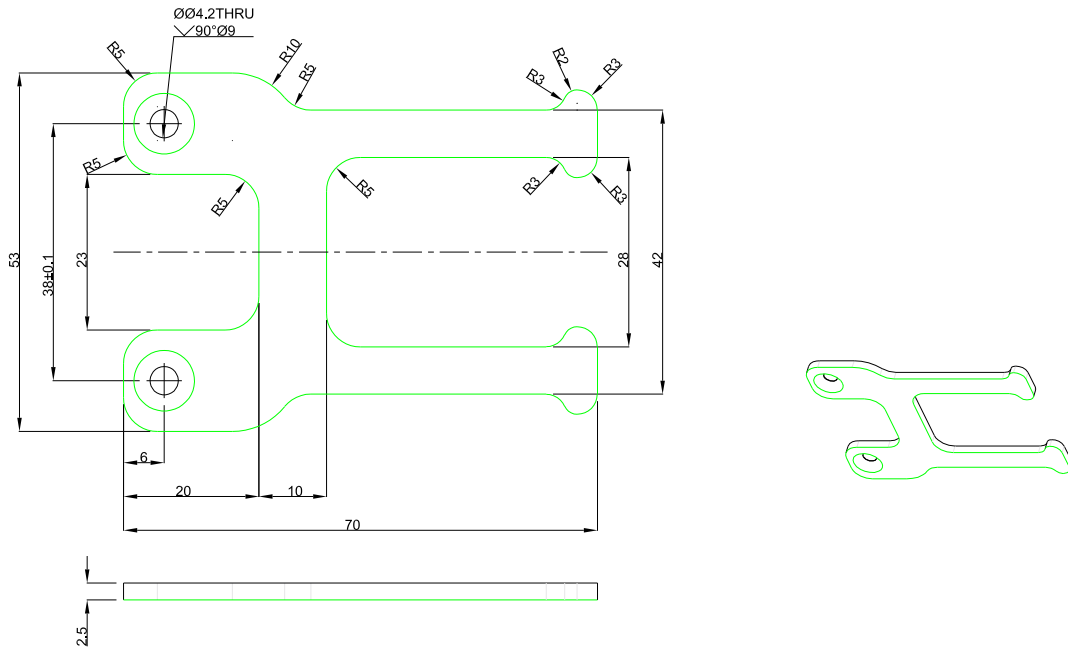

Cable Support Installation

Installation

Put the open holes of cable support together with the ports of the drive located on the right side of power supply input ports. Use the cross slotted head screw of M4*10 to connect the cable support and the drive.

Fixing

Use the PH2 screwdriver to tighten the screw.

