

www.phase.eu

TKH

SUPER HIGH TORQUE DENSITY, THIN RING TORQUE MOTOR SERIES

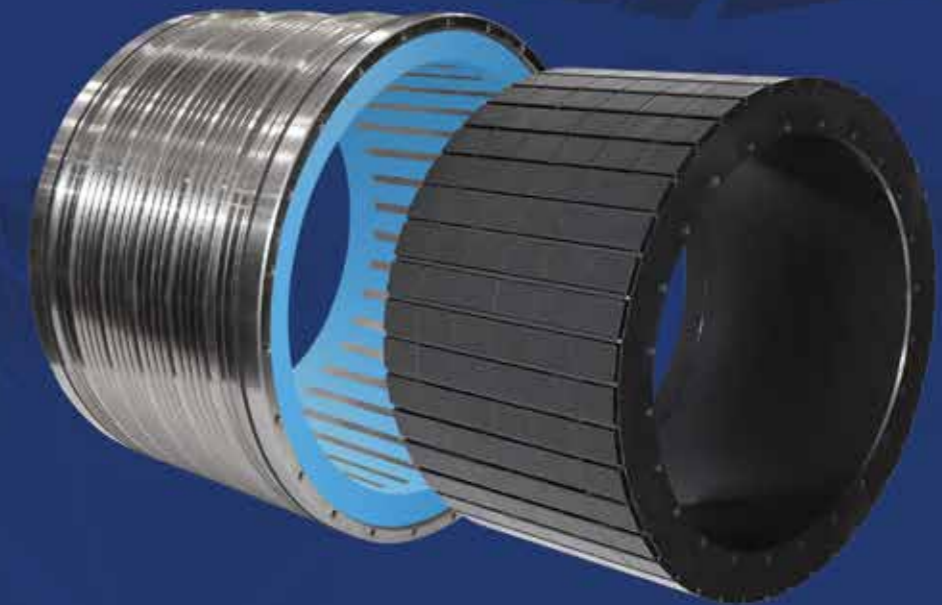

Phase Motion Control S.p.A.

Via Luigi Cibrario, 4 - 16154 Genova - Italy - Tel. +39 010 835161 - Fax +39 010 9998872 - P.IVA 03425740101

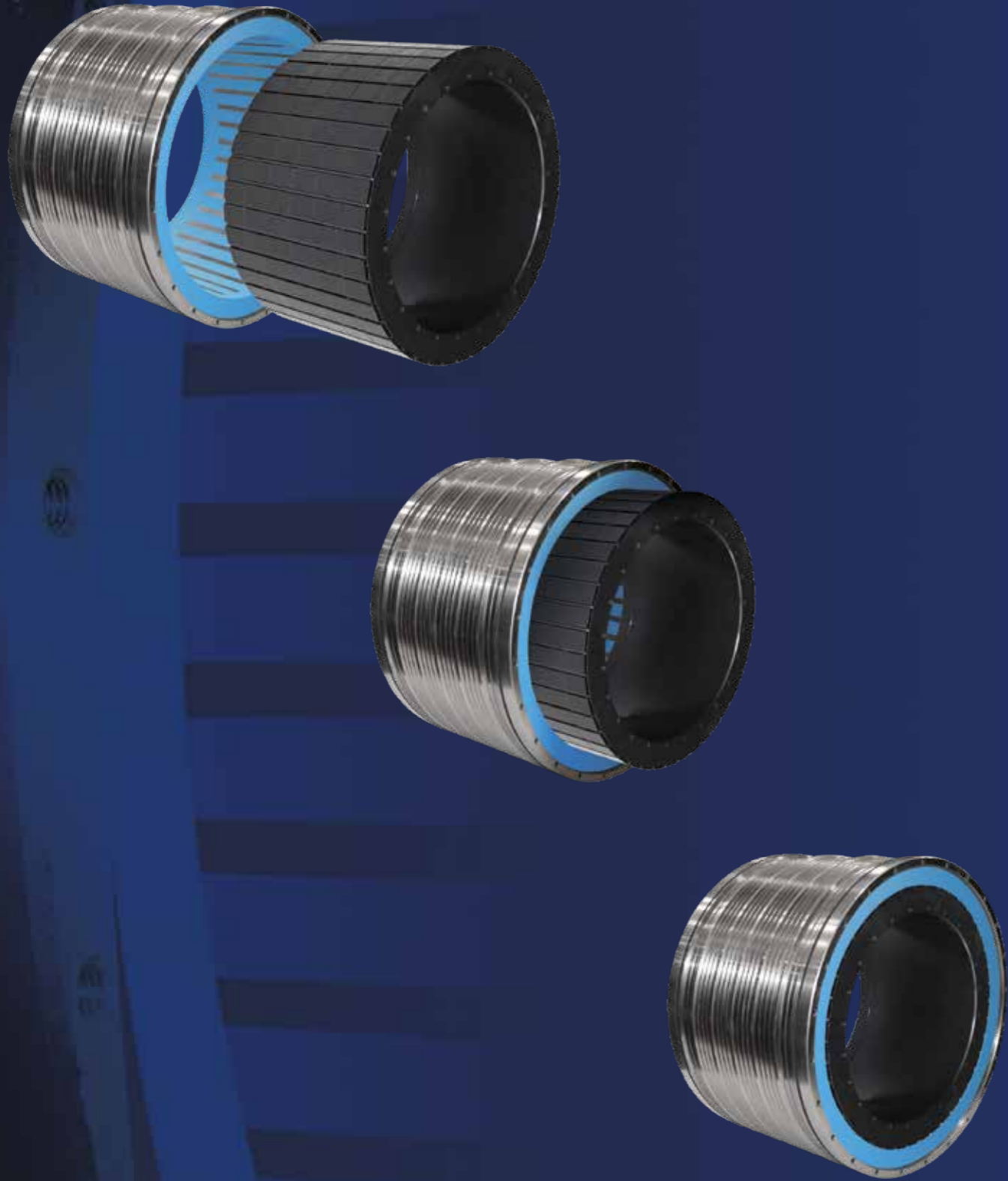

TKH

SUMMARY

- 04. COMPANY PROFILE
- 06. BACK TO ITALY
- 09. TKH GENERAL OVERVIEW
- 10. TKH CHARACTERISTICS
- 13. WHY TKH?
- 15. MOTOR SELECTION GUIDE
- 16. DETAIL SPECS
- 62. SERVICE & NETWORK



30%

*OF THE WORKFORCE IS DEDICATED TO R&D.
PHASE OPERATES AND CONTINUOUSLY DEVELOPS ITS OWN
TECHNOLOGIES AND INTERNATIONAL PATENTS IN THE GENOA HQ.
INNOVATION AND R&D COEXIST WITH AUTOMATED
PRODUCTION IN THE NEW GENOA BLUE GATE PLANT.*

SW, FW, HW: **ELECTRONIC AND ELECTROMECHANICAL** COMPONENTS AND SOLUTIONS FOR **CONTINUOUS PROGRESS** IN **MOTION CONTROL**

TKH — THIRD GENERATION DIRECT DRIVE TECHNOLOGY

Phase Motion Control first introduced **built-in Direct Drives** in co-engineered, customized applications back in **1992**. This progress, removing the flexure and nonlinearities (backlash and stick-slip) of all mechanical linkages, unleashed a **new level of performance** in terms of **accuracy, response speed** and **control bandwidth**. After 30 years of continuous innovation with DDs ranging from 30 mm to 18 m diameter, Phase is now introducing a **third generation frameless motor series** to push forward the limits of available performance again.

Phase Motion Control is this:

- 1. The aim of the Company is to **expand scientific knowledge** and to **progress technology** through **invention, design and efficient production of innovative devices** in the field of **cybernetics, motion control and energy conversion**, in the belief that the advance of science is as much the **driving force of humanity** as it is the only means of offering **the best future for all living beings**.*
- 1. The Company aims to make a profit, because **profit guarantees growth, independence and freedom of choice**, all factors which contribute towards the pursuit of its aims. Any profit which requires non ethical methods or which does not work towards the aims of the Company will not be pursued*
- 2. As **innovation and discovery** are exclusive to **individual creativity**, the Company considers its human capital at all levels to be the key asset of the firm and places it at the center of its interests. Accordingly, the Company promotes and demands **behavior which is ethical, just and open**, both internally and in its external relationships, in the belief that this is the only principle capable of guaranteeing the growth of any social group in the long term.*

PHASE MOTION CONTROL S.P.A. THE EXPERTISE CENTRE IN **POWER ELECTRONICS** AND **ENERGY CONTROL**

Phase Motion Control operates according to the Integrated Management System (IMS) for Quality, Health, Safety, and the Environment, certified by **TÜV SÜD** in 2022, based on **ISO 9001:2015, ISO 45001:2018, and ISO 14001:2015**.

Continuous innovation is fed by an interdisciplinary and intercompany team, spanning magnetics, mechanics, power electronics, advance electrochemistry and material science, both internally and via co-engineering with Customers, suppliers and partners, to define the moving frontier of energy technology.



BACK TO ITALY

THE TKH SERIES IS DESIGNED TO BE ENTIRELY MANUFACTURED IN ITALY WITH A MOSTLY LOCAL SUPPLY CHAIN AND INTERNAL PRODUCTION. THIS PROVIDES A SHORTER AND MORE RELIABLE SUPPLY CHAIN, INCREASED FLEXIBILITY AND FASTER RESPONSE TIMES.

THE HIGHLY MODULAR DESIGN IS OPTIMIZED TO GUARANTEE FASTER AVAILABILITY OF PARTS, REDUCING THE RISK OF STOCK SHORTAGES AND DOWNTIME.



High density, low radial width winding



Custom automatic winding equipment with on line testing



High speed machining



Rapid prototyping



Automated vacuum potting

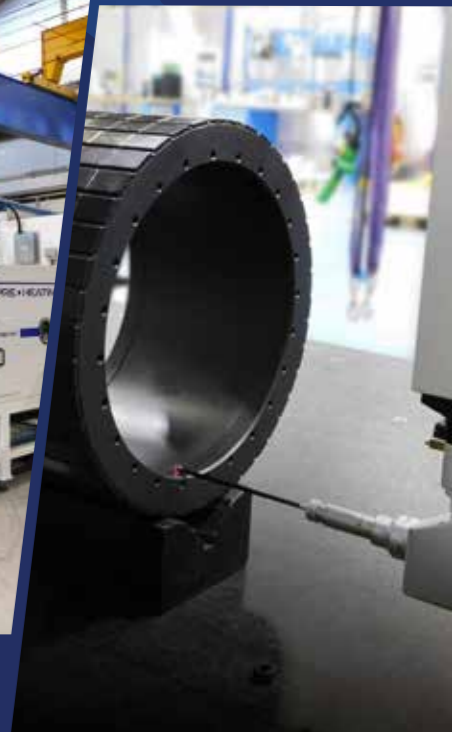

NC testing and certification

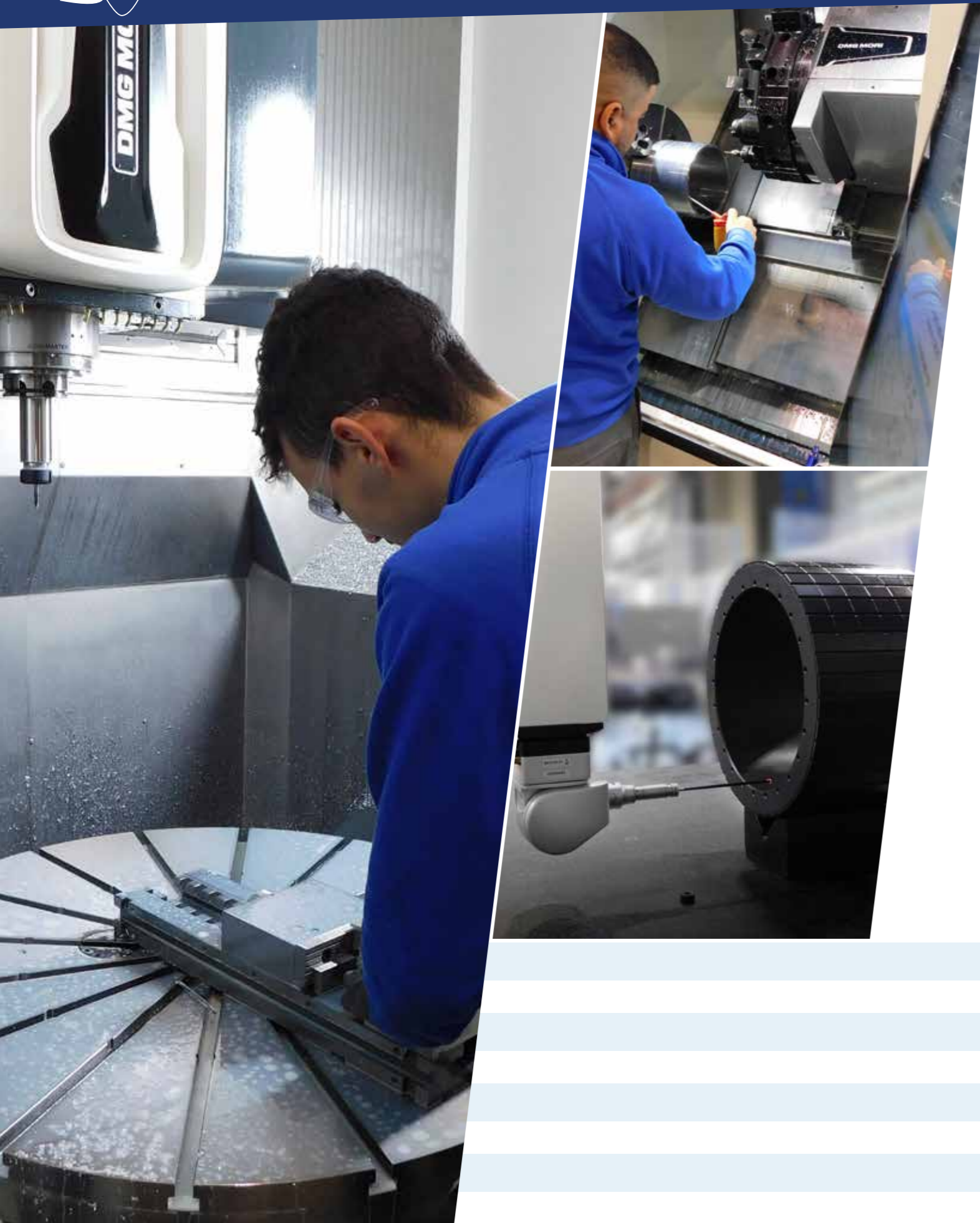

TKH HIGH TORQUE DENSITY THIN PROFILE FRAMELESS PM MOTORS

Designed to deliver exceptional performance in peak and continuous torque density, low to medium speed, with fast positioning ability. Equipped with an innovative electromagnetic circuit, the TKH series can handle even the most demanding applications requiring both low speed and fast transient positioning. The accurate magnetic circuit design and strict manufacturing tolerance design ensure low cogging ripple and smooth torque delivery.

UNLOCK THE **FULL POTENTIAL** OF YOUR **AUTOMATION**
AND **MOTION CONTROL** WITH THE TKH SERIES

KEY PERFORMANCE AND RANGE

11 DIFFERENT TKH SIZES, SPLIT INTO 100+ VARIANTS

ACTIVE STATOR LENGTH STACK UP TO 200 mm

EXTERNAL FRAME DIAMETER OPTIONS FROM 230 mm TO 1015 mm

INTERNAL ROTOR / SHAFT DIAMETER OPTIONS FROM 135 mm TO 865 mm

CONTINUOUS RATED TORQUE VALUES RANGING FROM 120 Nm TO 20.000 Nm

PEAK TORQUE UP TO 30.400 Nm

TKH CHARACTERISTICS

Engineered to excel in demanding applications, the TKH “frameless” motors are designed to be built into the equipment they are intended to drive, and to ride on the bearings of the equipment. They feature a three-phase stator, vacuum encapsulated in epoxy, assembled into a steel frame which carries the male part of the cooling circuit and its seals, and rare earth magnets and steel rotor, with an overall IP 20 protection rating. Actual motor protection is realized by the application.

TKH motors are designed to provide the best mechanical characteristics, with the most efficient cooling and the smallest machine footprint. These are obtained with novel, optimized magnetic design, special high density winding and a new high thermal conductivity vacuum potting epoxy resin.

STATOR CHARACTERISTICS

The TKH motors are the perfect choice for applications where compact size, high efficiency and absolute reliability are of the utmost importance. The TKH series boasts a new encapsulant (currently undergoing Class H development) with superior resistance to thermal cycling, exceptional thermal transfer and high peak temperature capability. This results in unparalleled thermal efficiency, making it an ideal choice for precision machines that are sensitive to thermal drift.

The TKH motors are engineered with a state-of-the-art winding concept, featuring surge-hardened Class H insulation, specifically designed for high $\Delta V/\Delta t$ according to IEC 60034-18-42:2017 Class 3 (Severe) standards. This reinforced insulation allows operation with DC bus voltage up to 750 Vdc, making the TKH series the perfect solution for demanding servo drive applications. **TKH series does not require the installation of a snubber anymore.**



The TKH series undergo rigorous testing to ensure the highest level of safety and performance, including a 4.5 kVdc phase-to-ground insulation voltage test for 60 seconds as well as 100% partial discharge testing.

The power leads are insulated with Radox 155, a material known for its exceptional mechanical and thermal resistance properties. This insulation ensures that the device operates reliably under a wide range of temperatures and conditions, making it a suitable option for various industrial and commercial applications.

TKH motors are equipped with two PT 1000 and three PTC 155 sensor probes. The PTCs are placed on each phase and are used for protection, while the redundant PT 1000 sensors are intended for temperature monitoring and are double insulated to protect the drive circuitry.

ROTOR CHARACTERISTICS

The permanent magnet rotors of the TKH series are isotropic, surface magnet type. Magnets are fastened mechanically on a magnetic circuit optimized to minimize cogging and ripple. This design provides for a very thin ring rotor. The coated FeNdB high temperature magnets ensure stability up to the max class temperature. The rotor to machine mechanical interface is realized out of machined C40 steel, uncoated and manufactured to Grade 8 tolerance, not balanced.

COOLING FRAME

The stator frame carries the inner part of the cooling circuit. The special cooling circuit is designed for maximum heat exchange with minimal pressure drop and efficient, uniform temperature control of the stator. The cooling circuit is completed by inserting the stator, complete with the peripheral O-rings, in the cylindrical assembly cavity of the application. Cooling fluid can be either water-glycole with a ionic stabilizer, or oil, with some derating. Care must be taken to avoid galvanic corrosion in the cooling circuit. Refer to TK manual for specific guidelines. The motor is equipped with one or two O-rings on each side to seal the cooling circuit and an intermediate leakage collection ring to protect against damage in case of O-ring failure, ensuring reliable operation.

Standard frames are machined out of C50 steel, normalized and phosphate conversion coating protected. This enhances corrosion resistance and improves performance while extending the service life of the system. Standard tolerance grade 8, higher accuracy can be supplied on demand.

All motors are equipped with 1 m power and sensor cables. This allows for easy integration and installation in various applications. Longer cables are discouraged as they increase the whole motor vulnerability.

For specialized applications, oil cooling is also an option. While not as thermally efficient, oil cooling has good dielectric properties and provides added protection against leaks.

When oil cooling is chosen, a 10% S1 torque derating is to be expected, as well as increased coolant flow and pressure drop compared to water/glycol systems. If oil cooling is required, a custom specification will be issued which will define performance derating and flow requirements.

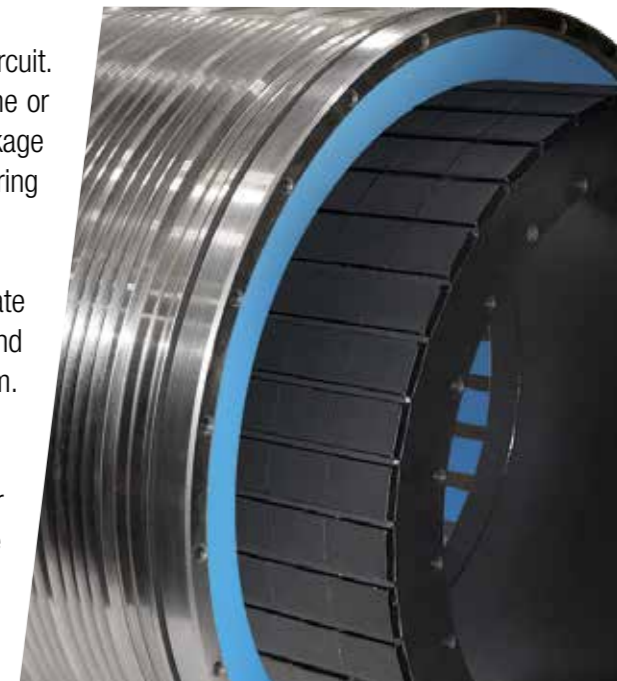

Assembly of the rotor into the stator is a critical process, due to intense magnetic forces and potential high voltage generation. This process needs special care and cannot be approached without specific preparation and tooling. Please refer to the user manual for detailed instructions and prescriptions.





WHY TKH?

The TKH design offers several advanced features which make them unique:

- > 20% TORQUE INCREASE OVER TK SERIES
- HIGHEST CONTINUOUS TORQUE DENSITY
- SUPER THIN RING DESIGN
- NO SNUBBER REQUIRED
- IMPROVED RESISTANCE TO THERMAL CYCLING WITH NEW CLASS H ENCAPSULANT
- UNMATCHED THERMAL EFFICIENCY FOR TEMPERATURE SENSITIVE, PRECISION MACHINES
- MAGNETIC DESIGN OPTIMIZED FOR LINEARITY IN OVERLOAD
- LOW COGGING AND RIPPLE TORQUE FOR SMOOTH OPERATION
- OPTIMIZED WATER COOLING CIRCUIT WITH CORROSION RESISTANT COATING
- HIGH DENSITY WINDING: LOWER LOSS, BETTER HEAT TRANSFER COMPARED TO CONVENTIONAL DESIGNS
- UL LISTING OPTION, AVAILABLE IN CLASS F
- SURGE HARDENED WINDING INSULATION FOR HIGH VOLTAGE OPERATION UP TO 750 VDC
- LIGHTWEIGHT AND SLIM DESIGN FOR EASY INTEGRATION
- FAST DELIVERY WITH MODULAR DESIGN
- MADE IN ITALY



MOTOR SELECTION GUIDE

CHOOSING THE RIGHT TKH MOTOR FOR YOUR APPLICATION

The TKH series of electric motors covers a wide range of diameters, which can in turn be realized with different stack lengths and windings. The large number of potential combinations can fit all specific needs. Special windings and stack lengths are available at the expense of a longer delivery. TKH motors are supplied as separate stator and rotor units, pre-assembled units with locking brackets are available on request.

TKH CODING

GENERAL CODING SYSTEM FOR TKH MOTORS:

TKH . XXX . YYY . ZZZ

TKH
Motor Series

Stator Stack outer diameter
as reported in the detailed
mechanical drawings

Active part length

Approximate torque constant
Kt coding example as reported below:
YYY.032 means 3,2 Nm/A
YYY.32 means 32 Nm/A
YYY.320 means 320 Nm/A

*It is possible to order a single stator and rotor with a specific code,
adding the following tag (ST/RT) to the main code:*

TKHST.XXX.YYY.ZZZ

TKHRT.XXX.YYY

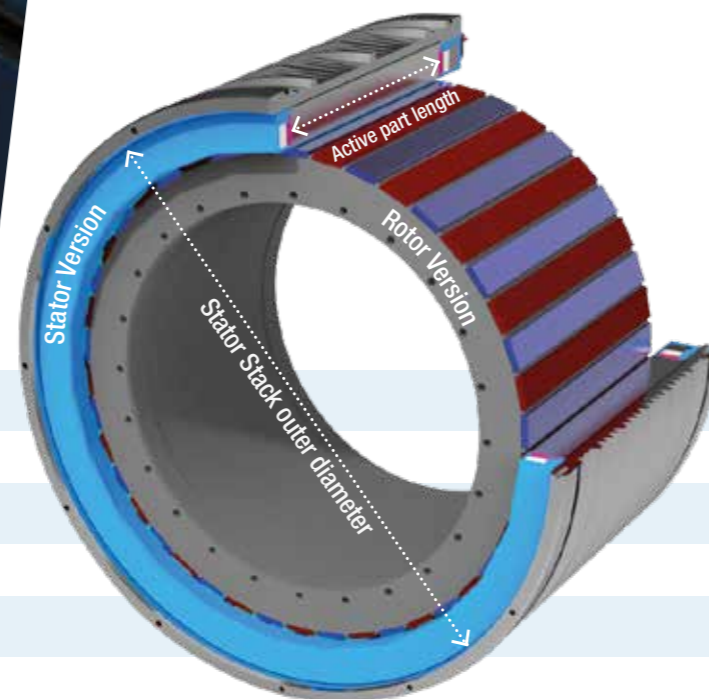

It's important to ensure that the correct code is used in order to receive the correct motor specifications and configurations for your application.

QUICK SELECTION GUIDE

AVAILABLE TORQUE AND DIAMETER RANGE

TKH motors offer a wide range of torque and diameter options to meet various application needs.

The available torque range and outside diameter options for TKH motors are:

- Outside diameters ranging from 230 to 1015 mm
- Different stack length modules in finite steps (50 - 100 - 150 - 200 mm)
- Winding configurations for different torque constant

Custom stack lengths by steps of 25mm and custom windings are available on demand.

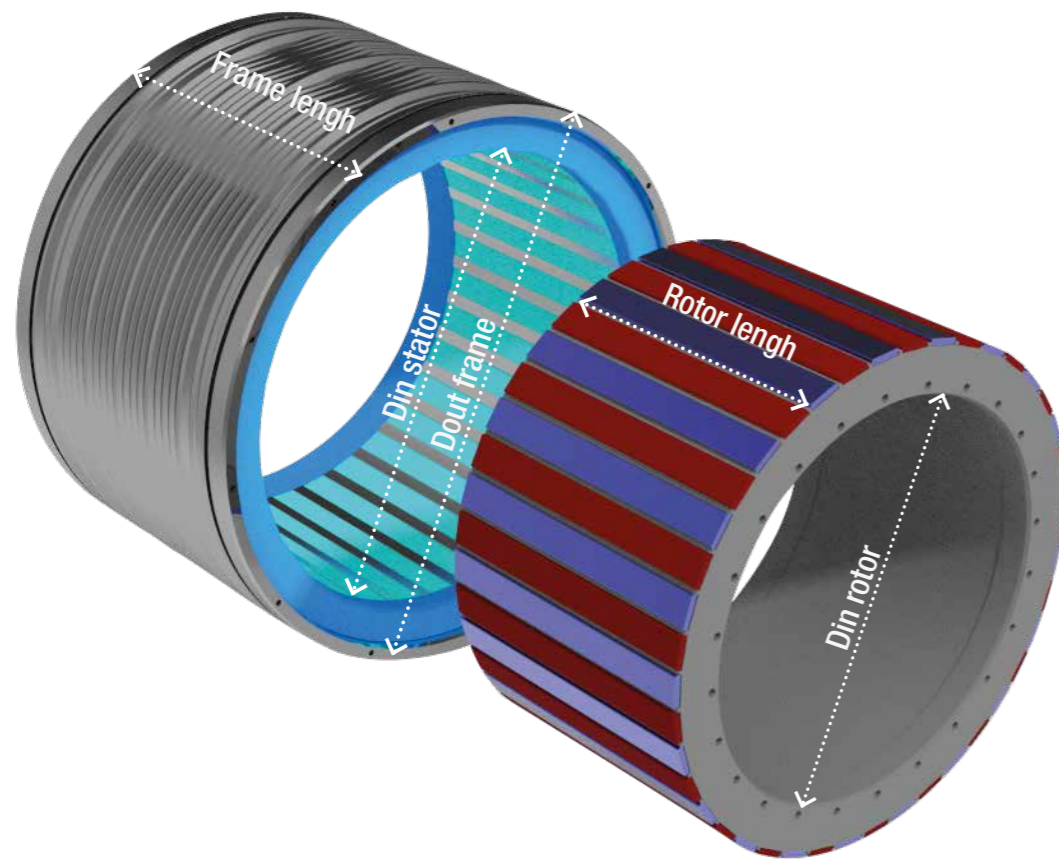

Note: The data reported are the maximum values for each TKH typology.
Please refer to the motor mechanical drawings for more details.

TKH motor code		Mech dimensions					Main performances								
TKH code	Stack	Dout frame [mm]	Din stator [mm]	Din rotor [mm]	Frame length [mm]	Rotor length [mm]	Continuous Torque min - max [Nm]		Peak Torque min - max [Nm]		Knee Speed min - max [rpm]		Max Continuous Speed min - max [rpm]		Max Transient Speed [rpm]
TKH 225	50	230	170	135	90	51	120	120	250	250	450	450	760	760	1150
	100	230	170	135	140	101	255	255	510	510	180	460	440	760	1150
	150	230	170	135	190	151	388	388	690	690	92	280	200	610	1150
	200	230	170	135	240	201	520	520	1020	1020	190	190	450	450	1150
TKH 295	50	310	255	215	90	51	265	267	594	598	165	400	480	510	770
	100	310	255	215	140	101	560	560	980	1200	58	290	230	510	770
	150	310	255	215	190	151	855	855	1096	1800	20	175	70	510	770
	200	310	255	215	240	201	1140	1140	2129	2410	60	120	240	380	770
TKH 365	50	385	304	265	92	51	518	522	852	855	112	258	430	430	650
	100	385	304	265	142	101	1110	1115	1710	1720	43	255	430	430	650
	150	385	304	265	192	151	1705	1705	2580	2580	68	160	430	430	650
	200	385	304	265	242	201	2300	2300	3440	3440	45	115	430	430	650
TKH 445	50	475	380	340	92	51	810	810	1290	1299	67	159	330	330	500
	100	475	380	340	142	101	1720	1730	2600	2600	22	200	250	330	500
	150	475	380	340	192	151	2650	2650	3910	3910	38	125	330	330	500
	200	475	380	340	242	201	3575	3575	5210	5210	24	90	330	330	500
TKH 525	50	550	456	420	95	51	1150	1160	1900	1910	42	170	420	420	420
	100	550	456	420	145	101	2460	2470	3830	3840	45	165	420	420	420
	150	550	456	420	195	151	3770	3770	5760	5760	24	107	420	420	420
	200	550	456	420	245	201	5110	5110	7680	7680	30	75	420	420	420
TKH 595	50	625	532	490	95	51	1580	1580	2560	2570	28	75	240	240	360
	100	625	532	490	145	101	3370	3370	5140	5150	30	140	240	240	360
	150	625	532	490	195	151	5140	5140	7720	7720	92	92	240	240	360
	200	625	532	490	245	201	6950	6950	10300	10300	65	65	240	240	360
TKH 675	50	705	608	565	95	51	2030	2030	3380	3380	55	128	210	210	320
	100	705	608	565	145	101	4360	4370	6815	6820	55	125	210	210	320
	150	705	608	565	195	151	6690	6690	10240	10240	33	80	210	210	320
	200	705	608	565	245	201	9000	9000	13660	13660	22	57	210	210	320
TKH 745	50	785	684	640	95	51	2550	2580	4200	4240	42	155	200	200	300
	100	785	684	640	145	101	5510	5510	8500	8510	30	110	200	200	300
	150	785	684	640	195	151	8470	8470	12770	12770	43	70	200	200	300
	200	785	684	640	245	201	11420	11420	17000	17000	30	50	200	200	300
TKH 825	50	860	760	715	97	51	3150	3170	5240	5270	33	100	160	160	250
	100	860	760	715	147	101	6750	6780	10550	10560	33	100	160	160	250
	150	860	760	715	197	151	10350	10350	15860	15860	27	63	160	160	250
	200	860	760	715	247	201	13980	13980	21150	21150	45	45	160	160	250
TKH 895	50	935	836	790	90	51	3810	3810	6390	6390	26	26	150	150	230
	100	935	836	790	147	101	8100	8100	12790	12790	90	90	150	150	230
	150	935	836	790	197	151	12440	12440	19220	19220	58	58	150	150	230
	200	935	836	790	247	201	16770	16770	25640	25640	40	40	150	150	230
TKH 975	50	1015	912	865	97	51	4480	4550	7520	7570	37	115	140	140	210
	100	1015	912	865	147	101	9670	9700	15180	15200	22	80	140	140	210
	150	1015	912	865	197	151	14900	14900	22810	22820	22	52	140	140	210
	200	1015	912	865	247	201	20000	20000	30400	30400	22	38	140	140	210

		050-12	100-12	100-24	150-18	150-36	200-24
Rated Torque	Nm	120	255	255	388	388	520
Knee Speed	rpm	450	460	180	280	92	190
Rated Power	kW	5,7	12,3	4,8	11,4	3,7	10,4
Rated Current	A	10,6	22,3	11,2	22,6	11,3	22,7
Torque Constant	Nm/A	12,08	12,08	24,16	18,12	36,24	24,16
Peak Torque	Nm	250	510	510	690	690	1020
Peak Current	A	24,9	50,0	24,9	43,3	21,6	49,7
S6 Torque	① Nm	175	359	359	553	553	737
Rated Torque at 0 rpm	Nm	90	188	188	285	285	381
Max Continuous Speed	② rpm	760	760	440	610	200	450
Max Transient Speed	rpm	1150	1150	1150	1150	1150	1150
Motor Constant	Nm/√W	3,79	5,89	5,89	7,48	7,48	8,80
Number of Poles	-	28	28	28	28	28	28
Back EMF Constant	③ V*s	6,97	6,97	13,95	10,46	20,92	13,95
Thermal Time Constant	s	148,0	130,3	130,0	124,3	124,1	121,4
Min Coolant Flow	④ l/min	2,8	4,9	4,8	6,9	6,8	8,8
Motor Losses	⑤ kW	1,7	3,0	3,0	4,3	4,3	5,6
Rotor Inertia	kg*m ²	0,015	0,026	0,026	0,038	0,038	0,049
Rotor Mass	kg	1,9	3,7	3,7	5,5	5,5	7,3
Stator Mass	kg	11	17	17	24	24	31

TEST CONDITIONS

- ① 40% duty, 60s cycle
- ② for higher continuous speed refer to TKH high-speed version
- ③ at 20°C
- ④ Δt 10°C
- ⑤ at 1 rpm

For higher speed solutions,
we have available TKH - HIGH SPEED version.
Please, contact our Technical Support Team
(support@phase.eu)
to find the best solution for your requirements.



TORQUE SPEED DIAGRAMS

TKH 225.050.12

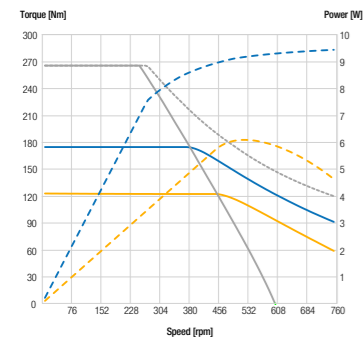

TKH 225.150.18

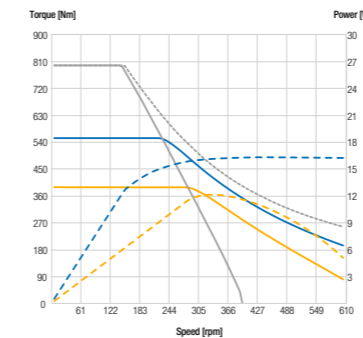

TKH 225.150.36

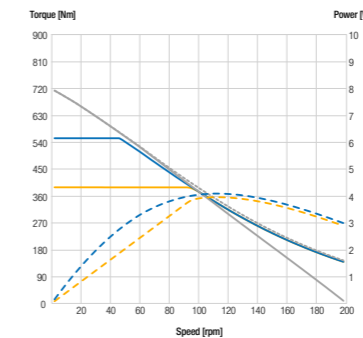

TKH 225.100.12

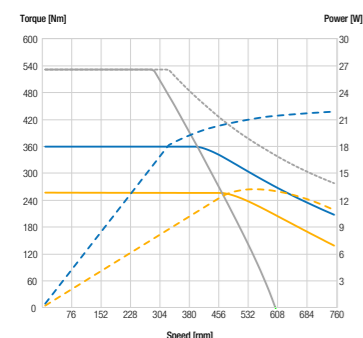

TKH 225.100.24

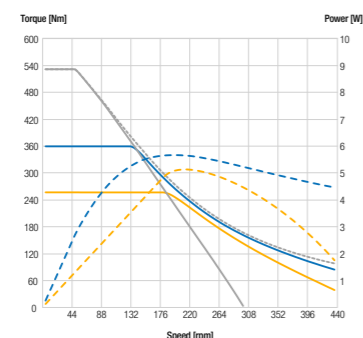

TKH 225.200.24

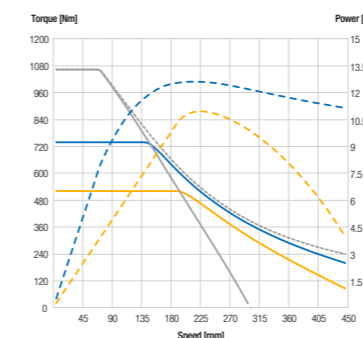

- S1 torque
- S6 torque, duty%
- Voltage saturation limit
- - - Saturation torque
- - - S1 power
- - - Peak power

We offer the flexibility to customize mechanical interfaces to suit your individual application needs, ensuring a seamless plug-and-play experience.

TECHNICAL DRAWING TKH 225

Rotor size TKHRT	Rotor fixing holes			Rotor dimensions	
	N_WS (min class)	N_OWS (min class)	b° (angular pitch)	L2 (Rotor length)	L3 (Centering length)
TKHRT 225 50	12 x M5 (8.8)	12 x M5 (8.8)	30°	51	10
TKHRT 225 100	18 x M5 (8.8)	18 x M5 (8.8)	20°	101	15
TKHRT 225 150	18 x M6 (8.8)	18 x M6 (8.8)	20°	151	15
TKHRT 225 200	24 x M6 (8.8)	24 x M6 (8.8)	15°	201	20

Stator size TKHST	Stator fixing holes			Stator Length L1
	N°_WS (min class)	N°_OWS (min class)	a° (angular pitch)	
TKHST 225 50	12 x M5 (8.8)	-	30°	90
TKHST 225 100	12 x M5 (8.8)	-	30°	140
TKHST 225 150	18 x M5 (8.8)	-	20°	190
TKHST 225 200	24 x M5 (8.8)	-	15°	240

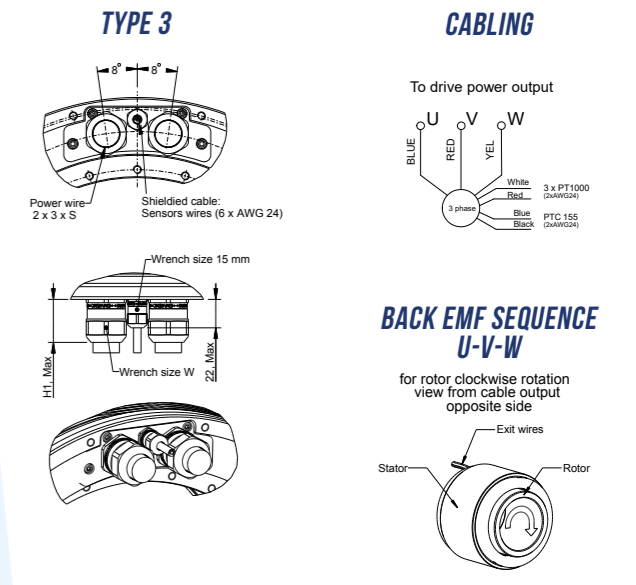
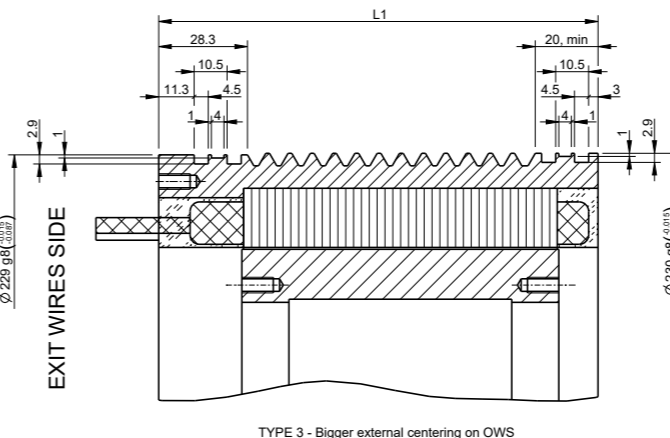
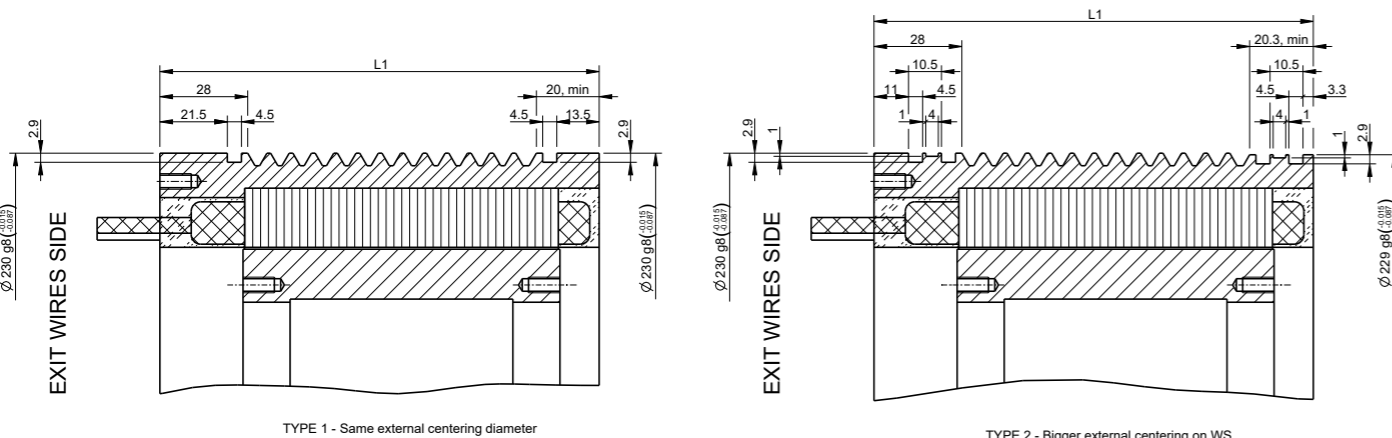
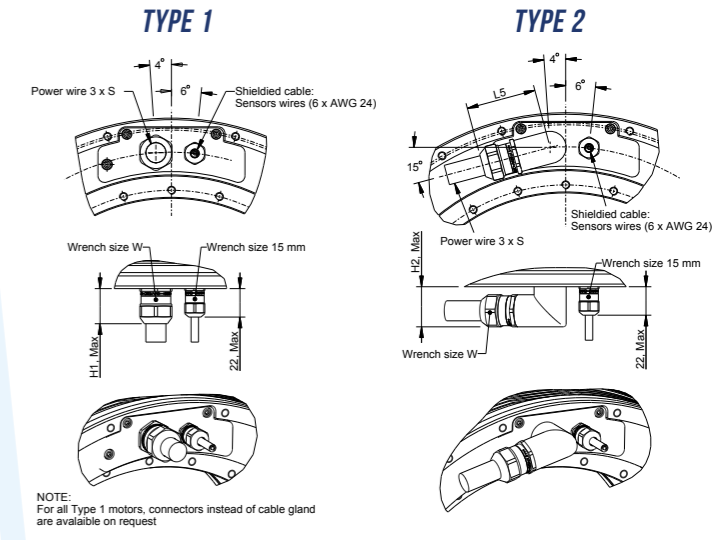
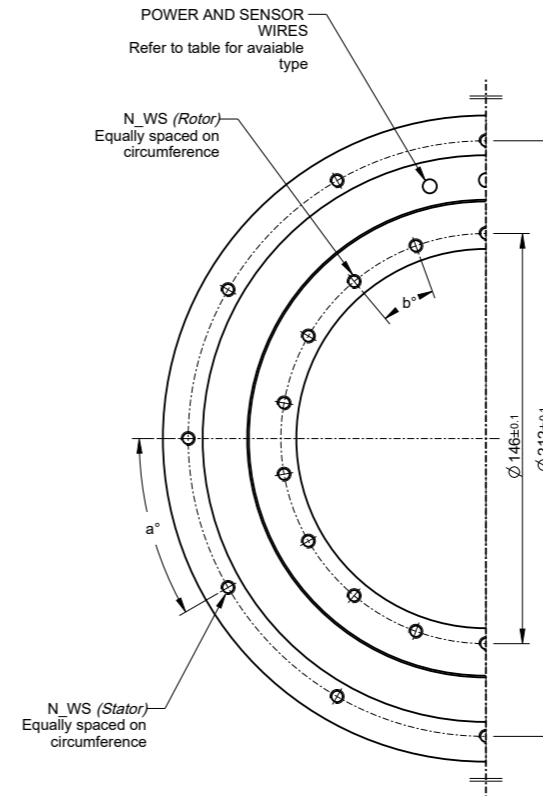
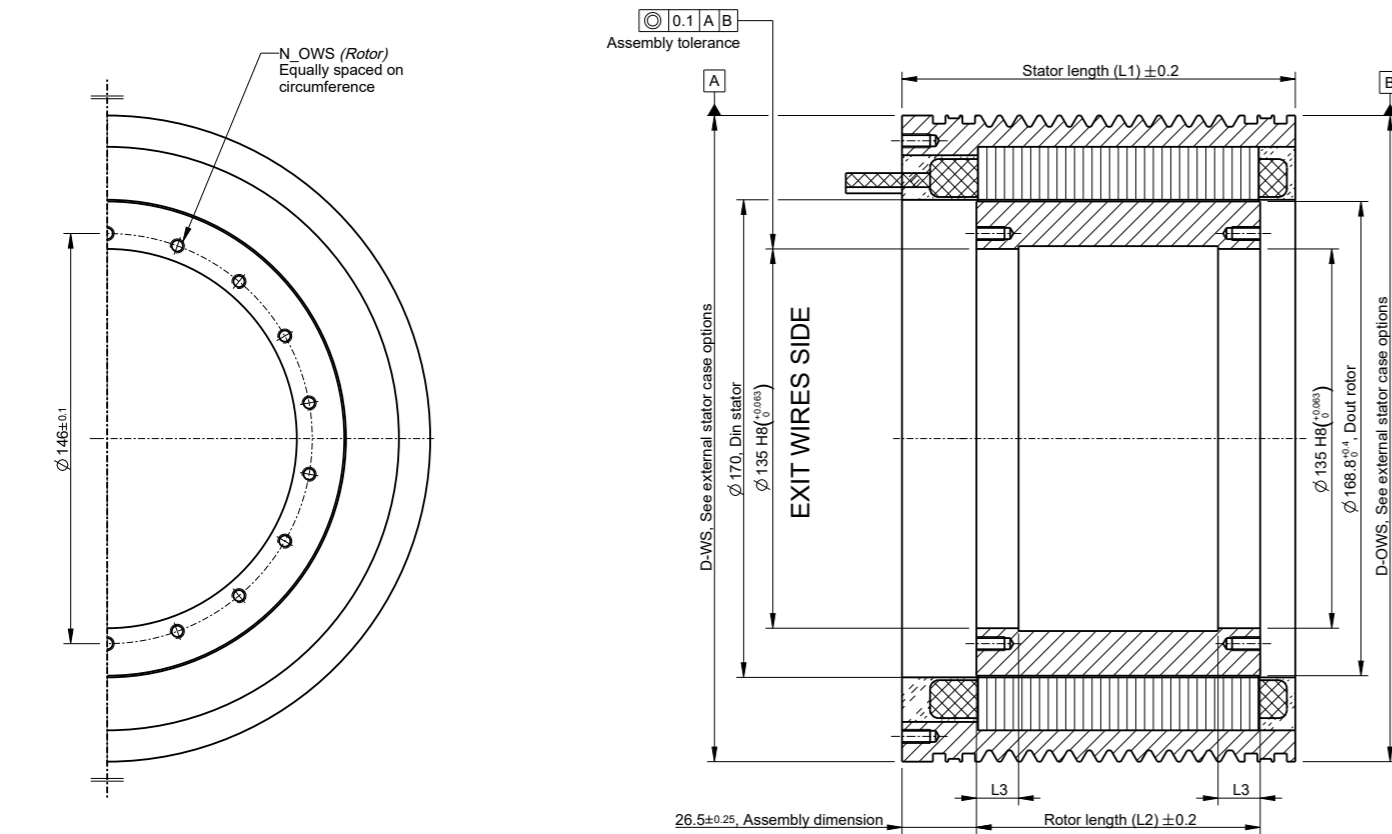

		050-13	050-27	100-18	100-27	100-54	150-27	150-40	150-81	200-36	200-54
Rated Torque	Nm	265	267	560	560	560	855	855	855	1140	1140
Knee Speed	rpm	400	165	290	175	58	175	100	20	120	60
Rated Power	kW	11,1	4,6	17,0	10,3	3,4	15,7	9,0	1,8	14,0	7,5
Rated Current	A	20,7	10,4	32,6	21,7	10,8	33,1	22,1	11,0	33,1	22,1
Torque Constant	Nm/A	13,65	27,30	18,20	27,30	54,61	37,30	40,95	81,91	36,40	54,61
Peak Torque	Nm	594	598	1200	1200	980	1800	1800	1096	2410	2129
Peak Current	A	53,2	26,6	79,7	53,1	20,1	79,5	53,0	14,3	80,0	44,9
S6 Torque	① Nm	393	393	808	808	808	1212	1212	1212	1616	1616
Rated Torque at 0 rpm	Nm	198	198	414	414	414	629	629	629	841	841
Max Continuous Speed	② rpm	510	480	510	510	230	510	330	70	380	240
Max Transient Speed	rpm	770	770	770	770	770	770	770	770	770	770
Motor Constant	Nm/√W	7,01	7,01	10,88	10,88	10,88	13,81	13,81	13,81	16,24	16,24
Number of Poles	-	42	42	42	42	42	42	42	42	42	42
Back EMF Constant	③ V*s	7,88	15,76	10,51	15,76	31,53	15,76	23,64	47,29	21,02	31,50
Thermal Time Constant	s	151,4	150,8	133,4	133,1	132,8	127,3	127,1	126,9	124,3	124,1
Min Coolant Flow	④ l/min	3,9	3,8	6,9	6,9	6,8	9,8	9,8	9,7	12,6	12,6
Motor Losses	⑤ kW	2,4	2,4	4,3	4,3	4,3	6,2	6,2	6,2	8,0	8,0
Rotor Inertia	kg*m ²	0,046	0,046	0,082	0,082	0,082	0,118	0,118	0,118	0,154	0,154
Rotor Mass	kg	2,5	2,5	4,9	4,9	4,9	7,3	7,3	7,3	9,7	9,7
Stator Mass	kg	15	15	25	25	25	34	34	34	44	44

TEST CONDITIONS

- ① 40% duty, 60s cycle
- ② for higher continuous speed refer to TKH high-speed version
- ③ at 20°C
- ④ Δt 10°C
- ⑤ at 1 rpm

*For higher speed solutions,
we have available TKH - HIGH SPEED version.
Please, contact our Technical Support Team
(support@phase.eu)
to find the best solution for your requirements.*



TORQUE SPEED DIAGRAM

TKH 295.050.13

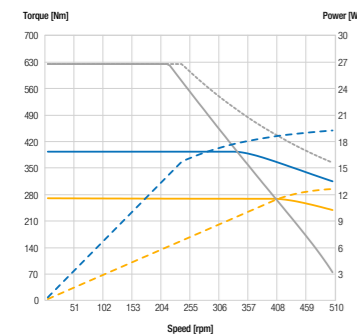

TKH 295.050.27

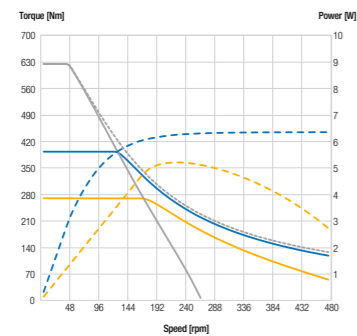

TKH 295.150.27

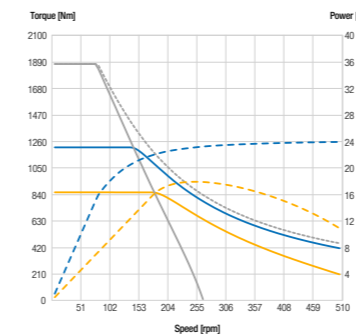

TKH 295.150.40

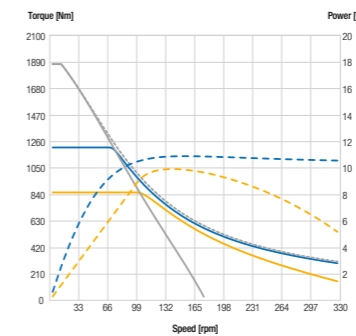

TKH 295.150.81

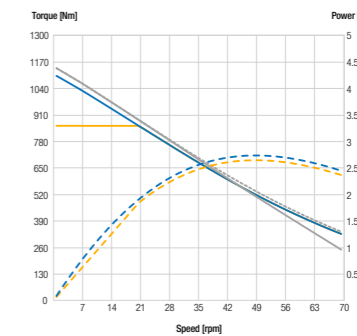

TKH 295.100.18

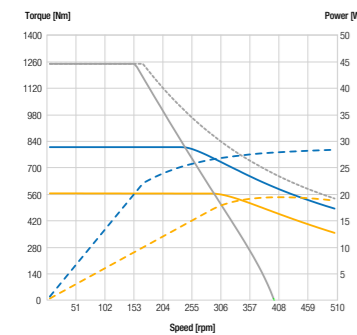

TKH 295.100.27

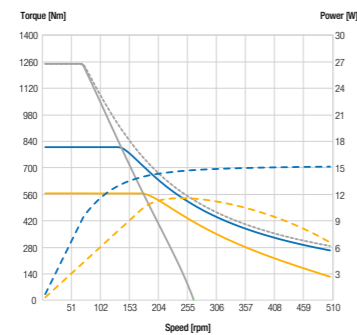

TKH 295.100.54

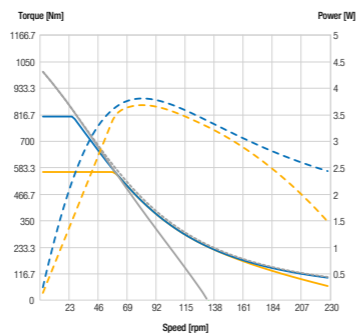

TKH 295.200.36

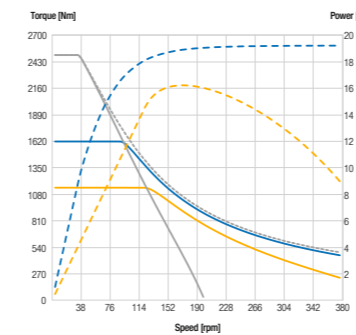

TKH 295.200.54

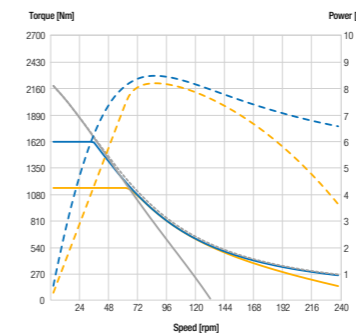

- S1 torque
- S6 torque, duty%
- Voltage saturation limit
- Saturation torque
- S1 power
- Peak power

We offer the flexibility to customize mechanical interfaces to suit your individual application needs, ensuring a seamless plug-and-play experience.

TECHNICAL DRAWING TKH 295

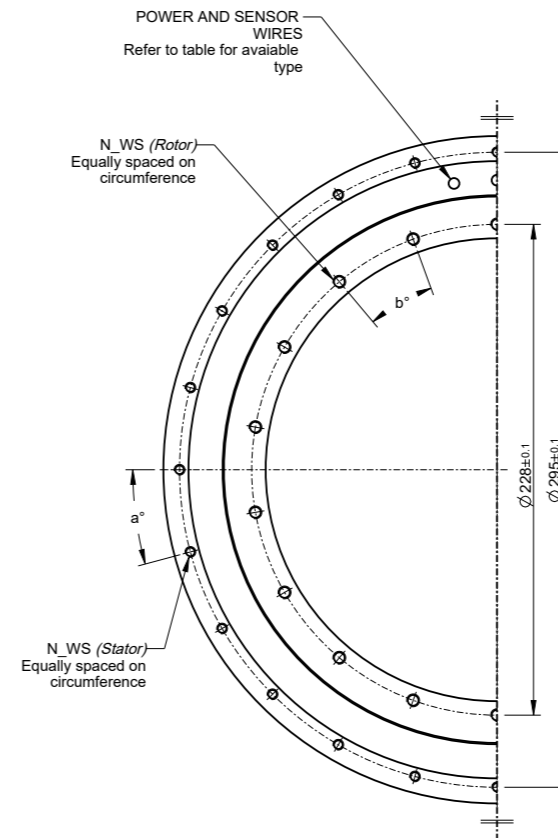
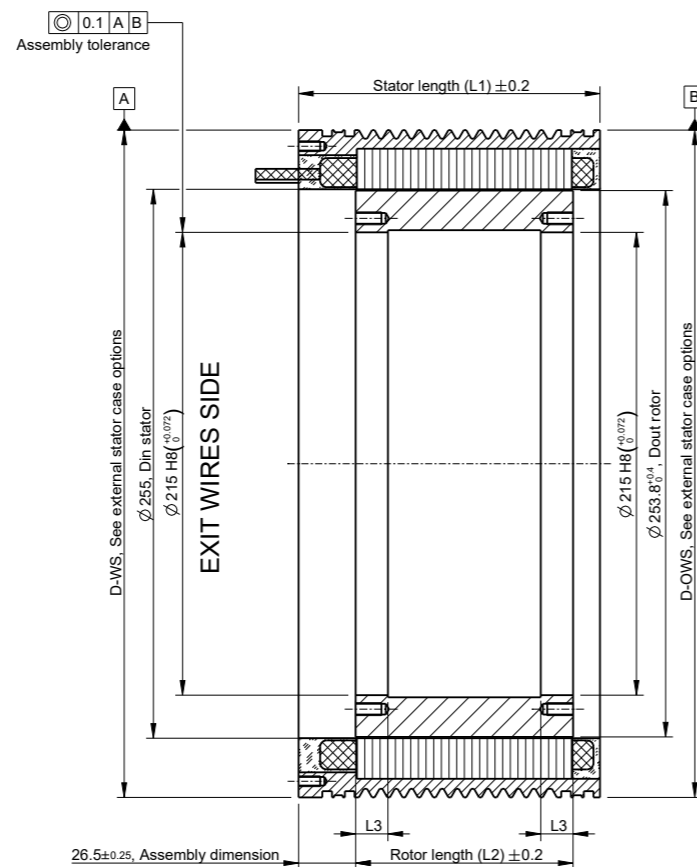
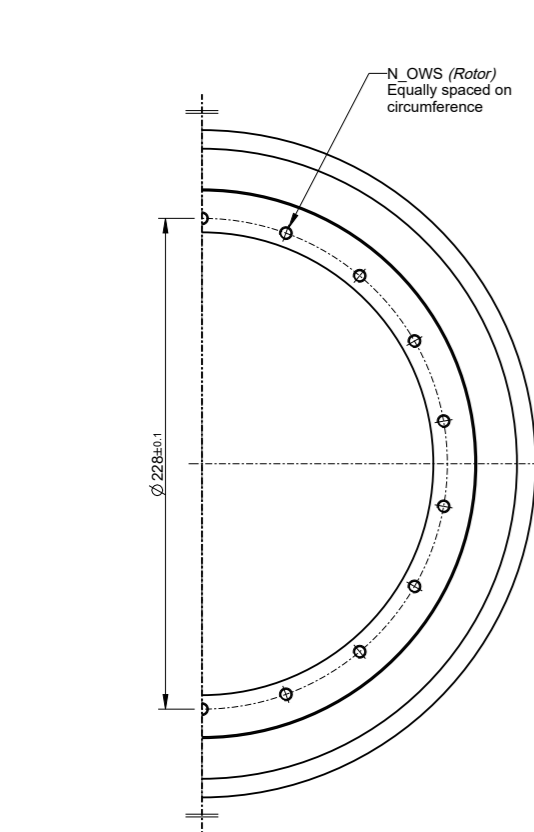

Rotor size TKHRT	Rotor fixing holes			Rotor dimensions	
	N_WS (min class)	N_OWS (min class)	b° (angular pitch)	L2 (Rotor length)	L3 (Centering length)
TKHRT 295 50	12 x M6 (8.8)	12 x M6 (8.8)	30°	51	10
TKHRT 295 100	18 x M6 (8.8)	18 x M6 (8.8)	20°	101	15
TKHRT 295 150	30 x M6 (8.8)	30 x M6 (8.8)	12°	151	15
TKHRT 295 200	24 x M8 (8.8)	24 x M8 (8.8)	15°	201	20

Stator size TKHST	Stator fixing holes			Stator Length L1
	N°_WS (min class)	N°_OWS (min class)	a° (angular pitch)	
TKHST 295 50	12 x M5 (8.8)	-	30°	90
TKHST 295 100	24 x M5 (8.8)	-	15°	140
TKHST 295 150	30 x M5 (8.8)	-	12°	190
TKHST 295 200	30 x M6 (8.8)	-	12°	240

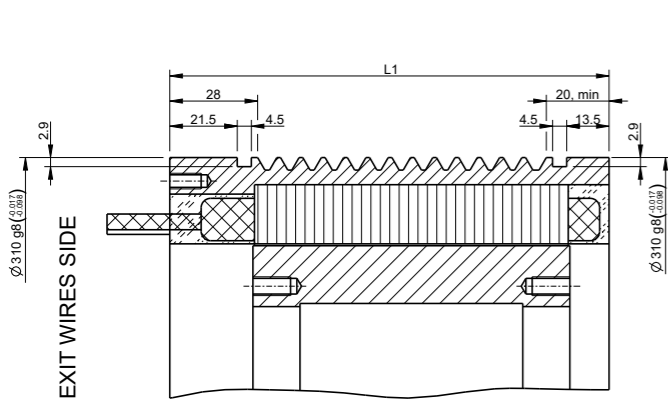

TYPE 1 - Same external centering diameter

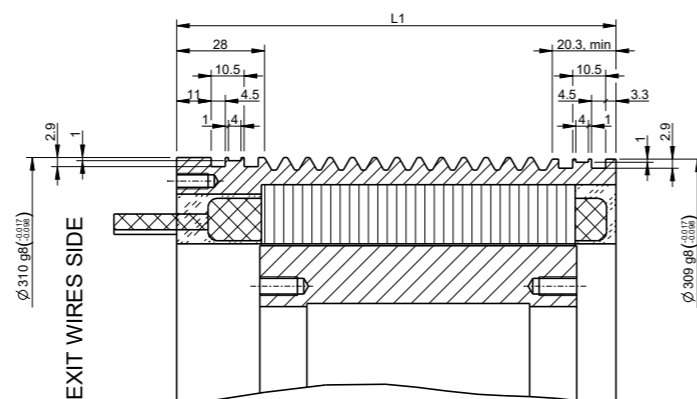

TYPE 2 - Bigger external centering on WS

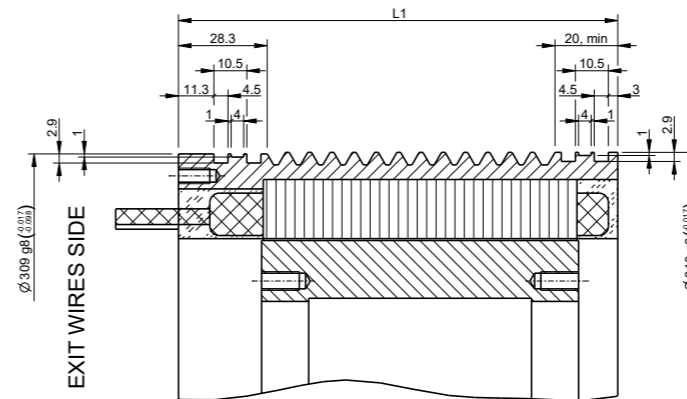

TYPE 3 - Bigger external centering on OWS

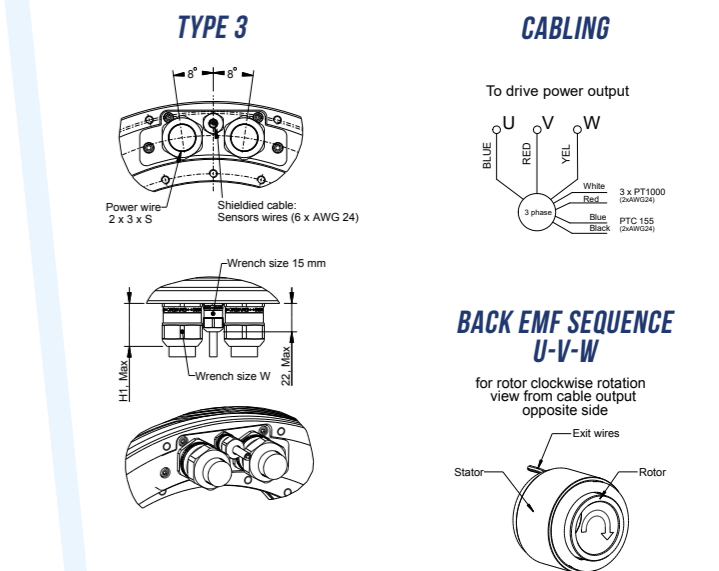
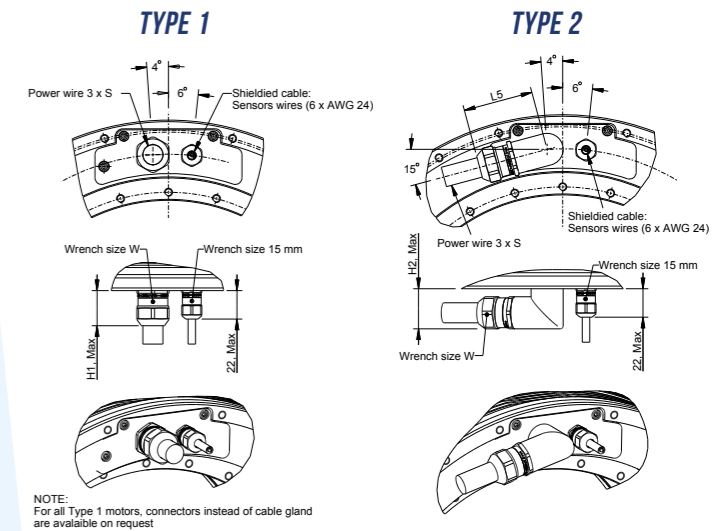

		050-19	050-38	100-19	100-38	100-77	150-29	150-58	200-38	200-77
Rated Torque	Nm	518	522	1110	1110	1115	1705	1705	2300	2300
Knee Speed	rpm	258	112	255	115	43	160	68	115	45
Rated Power	kW	14,0	6,1	29,6	13,4	5,0	28,6	12,1	27,7	10,8
Rated Current	A	29,2	14,7	63,0	55,5	15,8	64,6	32,3	65,5	32,7
Torque Constant	Nm/A	19,35	38,71	19,35	38,71	77,42	29,03	58,06	38,71	77,42
Peak Torque	Nm	852	855	1710	1710	1720	2580	2580	3440	3440
Peak Current	A	56,0	27,9	111,2	55,5	28,0	111,9	55,9	111,9	55,9
S6 Torque	① Nm	754	754	1576	1576	1576	2398	2398	3197	3197
Rated Torque at 0 rpm	Nm	386	386	822	822	822	1259	1259	1694	1694
Max Continuous Speed	② rpm	430	430	430	430	430	430	430	430	430
Max Transient Speed	rpm	650	650	650	650	650	650	650	650	650
Motor Constant	Nm/√W	12,75	12,75	20,08	20,08	20,08	25,64	25,64	30,27	30,27
Number of Poles	-	56	56	56	56	56	56	56	56	56
Back EMF Constant	③ V*s	11,17	22,35	19,35	22,35	44,70	16,76	33,52	22,35	44,70
Thermal Time Constant	s	256,5	255,0	225,1	224,0	223,3	214,0	213,3	208,5	208,0
Min Coolant Flow	④ l/min	4,7	4,6	8,7	8,6	8,6	12,5	12,5	16,3	16,3
Motor Losses	⑤ kW	2,9	2,9	5,3	5,3	5,3	7,8	7,8	10,1	10,1
Rotor Inertia	kg*m ²	0,082	0,082	0,145	0,145	0,145	0,209	0,209	0,273	0,273
Rotor Mass	kg	3,0	3,0	6,0	6,0	6,0	9,0	9,0	12,0	12,0
Stator Mass	kg	25	25	41	41	41	58	58	74	74

TEST CONDITIONS

- ① 40% duty, 60s cycle
- ② for higher continuous speed refer to TKH high-speed version
- ③ at 20°C
- ④ Δt 10°C
- ⑤ at 1 rpm

*For higher speed solutions,
we have available TKH - HIGH SPEED version.
Please, contact our Technical Support Team
(support@phase.eu)
to find the best solution for your requirements.*



TORQUE SPEED DIAGRAM

TKH 365.050.19

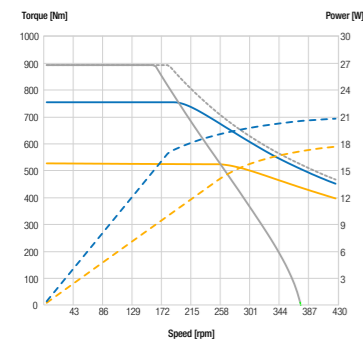

TKH 365.050.38

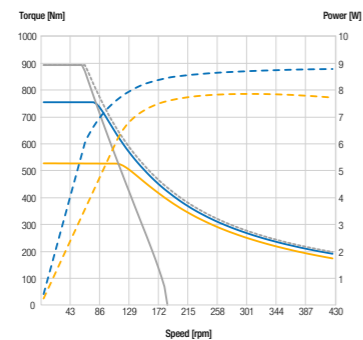

TKH 365.150.29

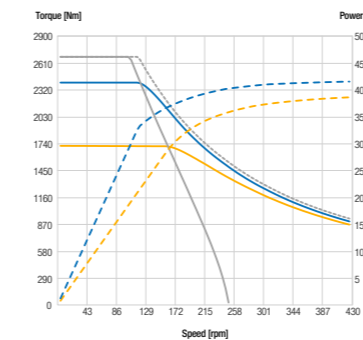

TKH 365.150.58

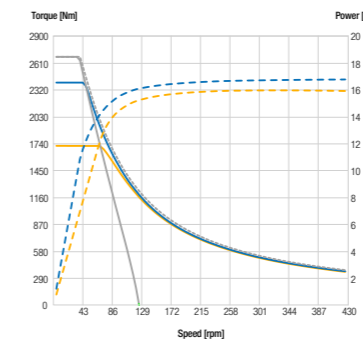

TKH 365.100.19

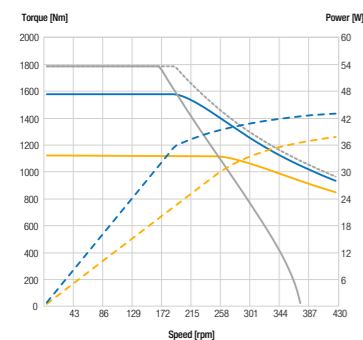

TKH 365.100.38

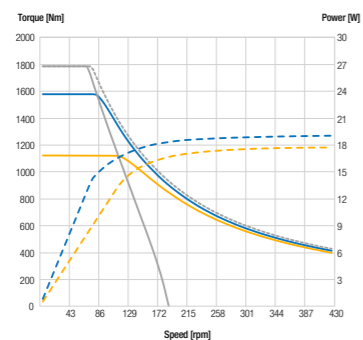

TKH 365.100.77

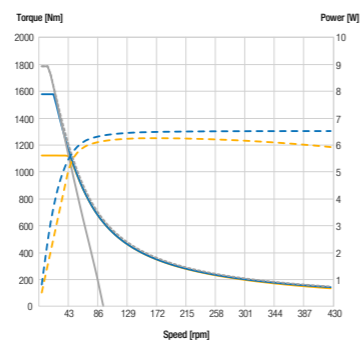

TKH 365.200.38

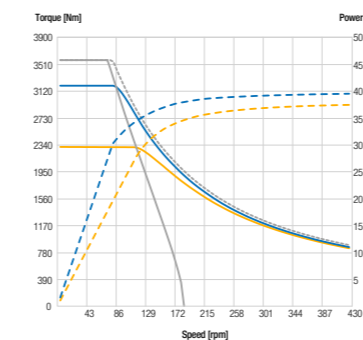

TKH 365.200.77

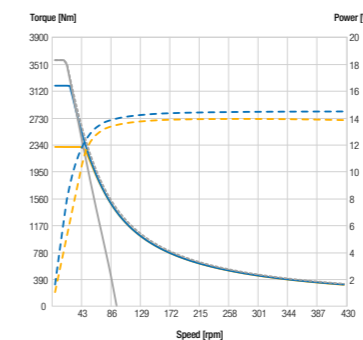

- S1 torque
- S6 torque, duty%
- Voltage saturation limit
- - - Saturation torque
- - - S1 power
- - - Peak power

We offer the flexibility to customize mechanical interfaces to suit your individual application needs, ensuring a seamless plug-and-play experience.

TECHNICAL DRAWING TKH 365

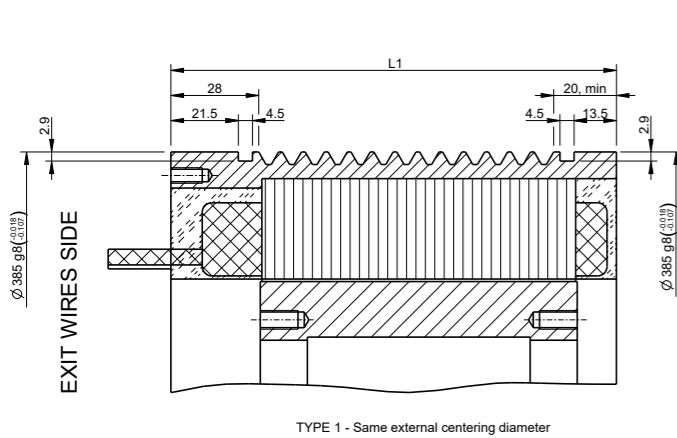
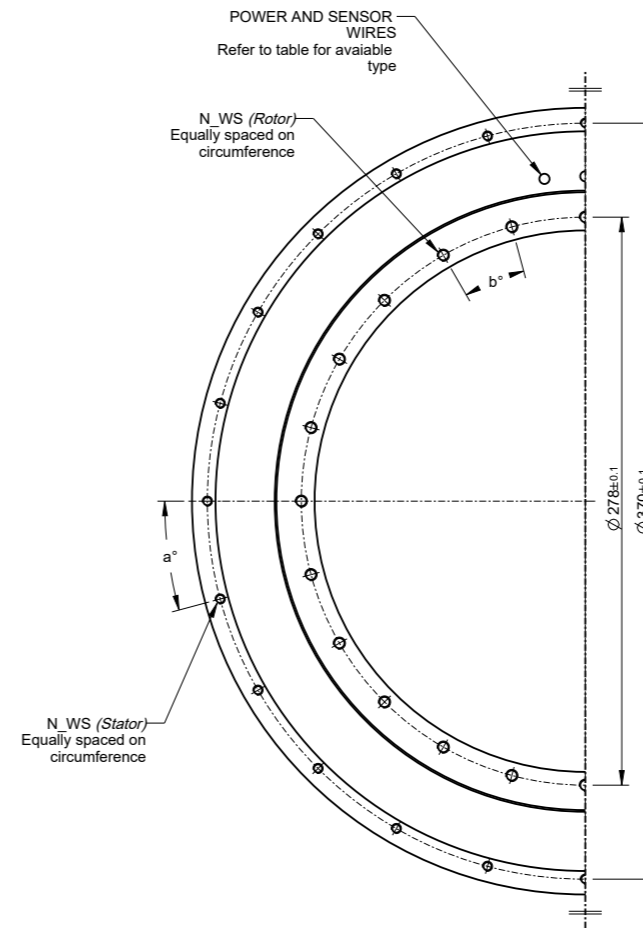
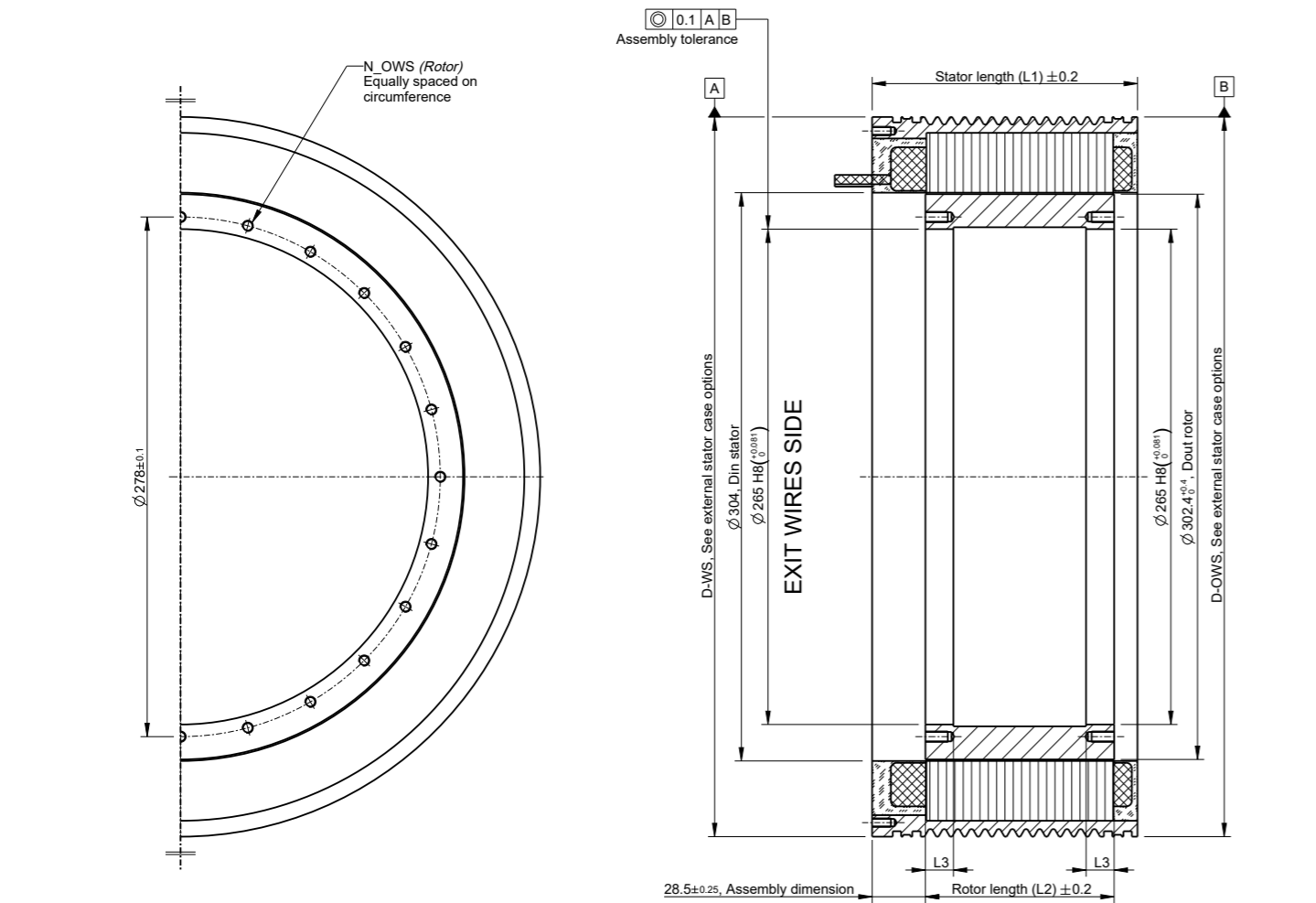

TYPE 1 - Same external centering diameter

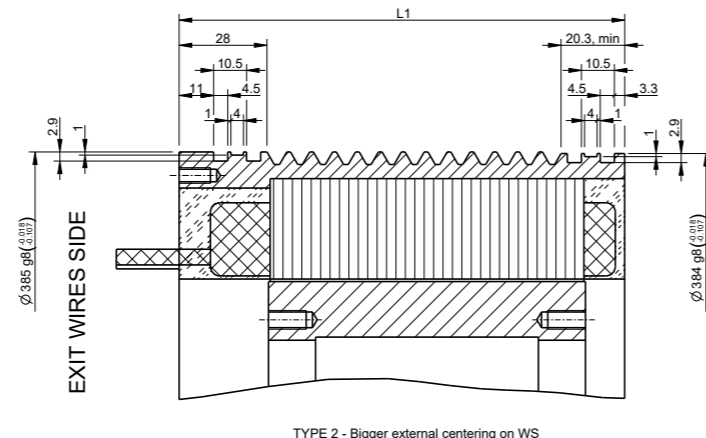

TYPE 2 - Bigger external centering on WS

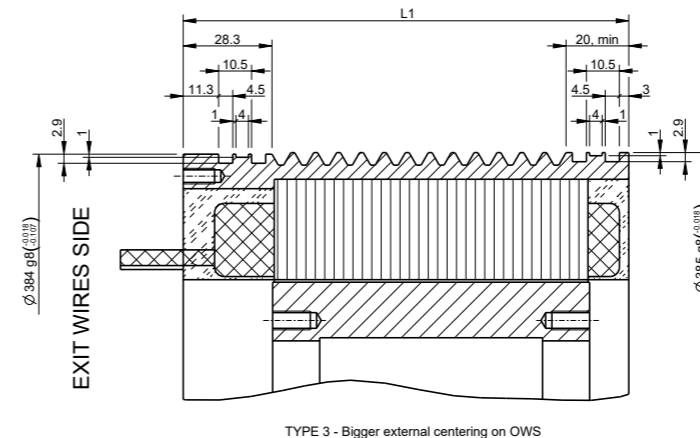

TYPE 3 - Bigger external centering on OWS

Rotor size TKHRT	Rotor fixing holes			Rotor dimensions	
	N_WS (min class)	N_OWS (min class)	b° (angular pitch)	L2 (Rotor length)	L3 (Centering length)
TKHRT 365 50	12 x M6 (8.8)	12 x M6 (8.8)	30°	51	10
TKHRT 365 100	24 x M6 (8.8)	24 x M6 (8.8)	15°	101	15
TKHRT 365 150	18 x M8 (8.8)	18 x M8 (8.8)	20°	151	15
TKHRT 365 200	24 x M8 (8.8)	24 x M8 (8.8)	15°	201	20

Stator size TKHST	Stator fixing holes			Stator Length L1
	N°_WS (min class)	N°_OWS (min class)	a° (angular pitch)	
TKHST 365 50	12 x M5 (8.8)	-	30°	92
TKHST 365 100	24 x M5 (8.8)	-	15°	142
TKHST 365 150	36 x M5 (8.8)	-	10°	192
TKHST 365 200	30 x M6 (8.8)	-	12°	242

TYPE 1

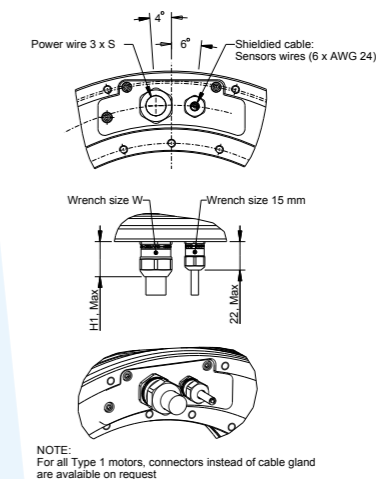

NOTE:
For all Type 1 motors, connectors instead of cable gland are available on request

TYPE 2

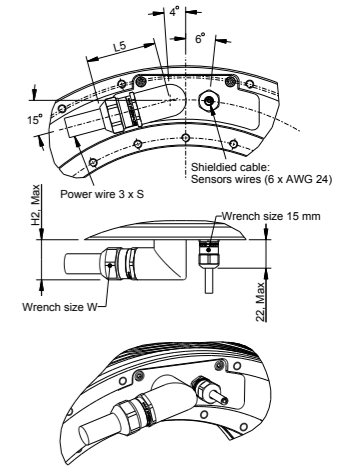

TYPE 3

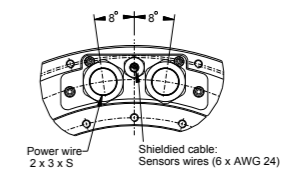

CABLING

To drive power output

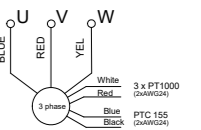

BACK EMF SEQUENCE U-V-W

for rotor clockwise rotation view from cable output opposite side

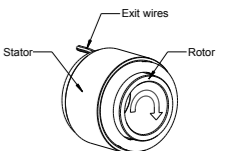

		050-30	050-61	100-24	100-61	100-122	150-36	150-91	200-48	200-122
Rated Torque	Nm	810	810	1720	1730	1730	2650	2650	3575	3575
Knee Speed	rpm	159	67	200	68	22	125	38	90	24
Rated Power	kW	13,5	5,7	36,2	12,3	4,0	34,7	10,6	33,7	9,0
Rated Current	A	29,2	14,5	78,0	31,3	15,7	80,4	32,1	81,5	32,6
Torque Constant	Nm/A	30,52	61,04	24,42	61,04	122,09	36,63	91,57	48,84	122,09
Peak Torque	Nm	1290	1299	2600	2600	2600	3910	3910	5210	5210
Peak Current	A	53,5	26,9	134,1	53,5	26,7	134,3	53,7	134,1	53,6
S6 Torque	① Nm	1174	1174	2421	2421	2421	3696	3685	4983	4983
Rated Torque at 0 rpm	Nm	598	598	1274	1274	1274	1951	1951	2625	2625
Max Continuous Speed	② rpm	330	330	330	330	250	330	330	330	300
Max Transient Speed	rpm	500	500	500	500	500	500	500	500	500
Motor Constant	Nm/√W	18,00	18,00	28,33	28,33	28,33	36,17	36,17	42,71	42,71
Number of Poles	-	70	70	70	70	70	70	70	70	70
Back EMF Constant	③ V*s	17,62	35,24	14,10	35,24	70,49	21,15	52,87	28,20	70,49
Thermal Time Constant	s	257,7	256,2	226,9	225,4	224,6	215,8	214,8	210,2	209,5
Min Coolant Flow	④ l/min	5,7	5,7	10,6	10,5	10,5	15,3	15,3	20,0	19,9
Motor Losses	⑤ kW	3,5	3,5	6,6	6,6	6,6	9,5	9,5	12,4	12,4
Rotor Inertia	kg*m ²	0,17	0,17	0,30	0,30	0,30	0,43	0,43	0,57	0,57
Rotor Mass	kg	4,0	4,0	7,9	7,9	7,9	11,8	11,8	15,7	15,7
Stator Mass	kg	30	30	51	51	51	71	71	91	91

TEST CONDITIONS

- ① 40% duty, 60s cycle
- ② for higher continuous speed refer to TKH high-speed version
- ③ at 20°C
- ④ Δt 10°C
- ⑤ at 1 rpm

*For higher speed solutions,
we have available TKH - HIGH SPEED version.
Please, contact our Technical Support Team
(support@phase.eu)
to find the best solution for your requirements.*



TORQUE SPEED DIAGRAM

TKH 445.050.30

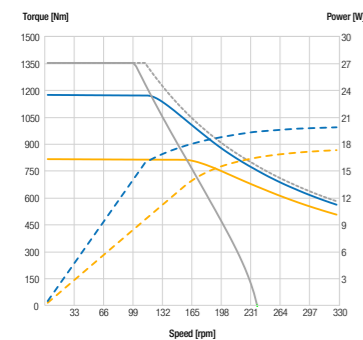

TKH 445.050.61

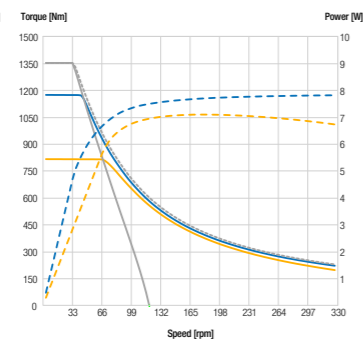

TKH 445.150.36

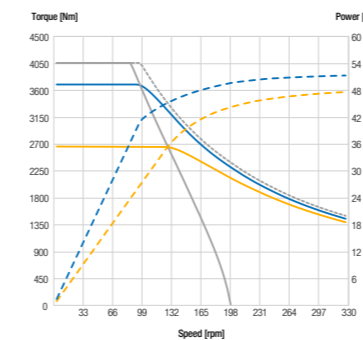

TKH 445.150.91

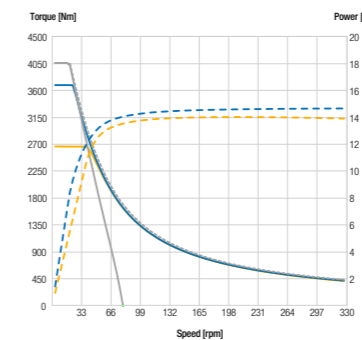

TKH 445.100.24

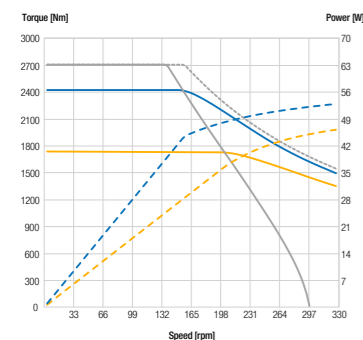

TKH 445.100.61

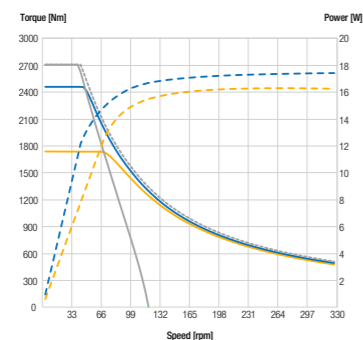

TKH 445.100.122

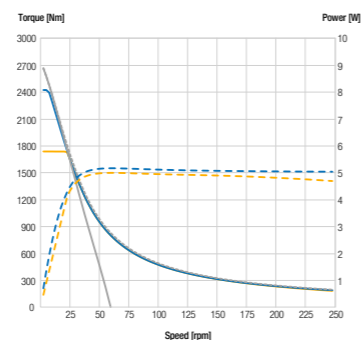

TKH 445.200.48

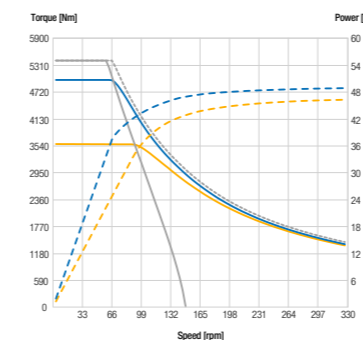

TKH 445.200.122

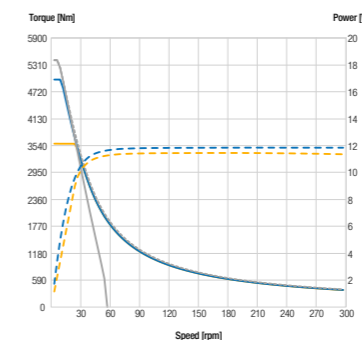

- S1 torque
- S6 torque, duty%
- Voltage saturation limit
- Saturation torque
- S1 power
- Peak power

We offer the flexibility to customize mechanical interfaces to suit your individual application needs, ensuring a seamless plug-and-play experience.

TECHNICAL DRAWING TKH 445

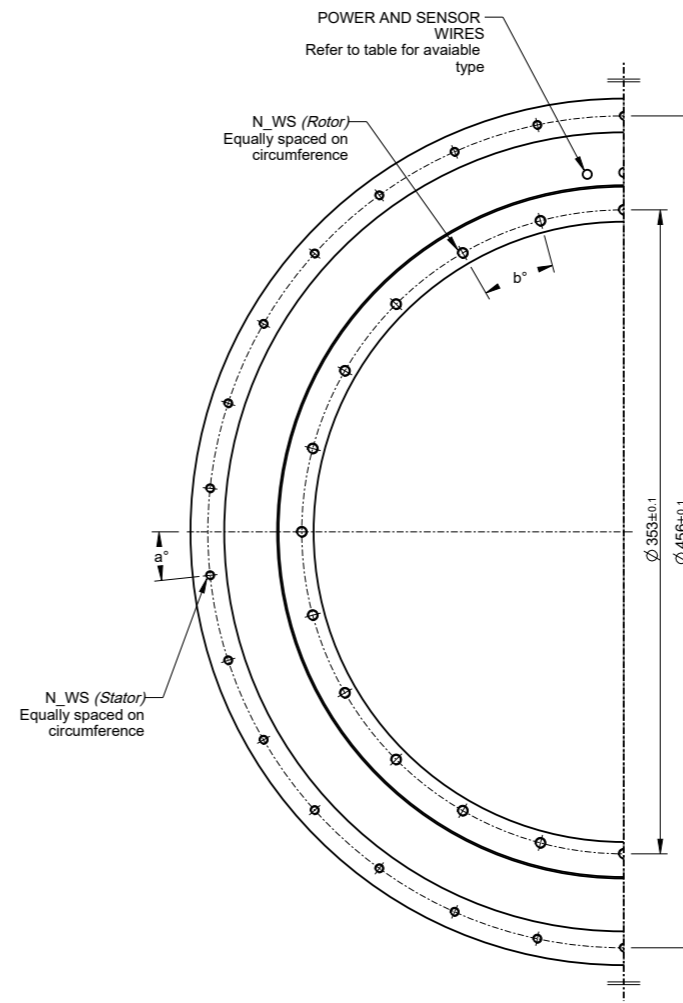
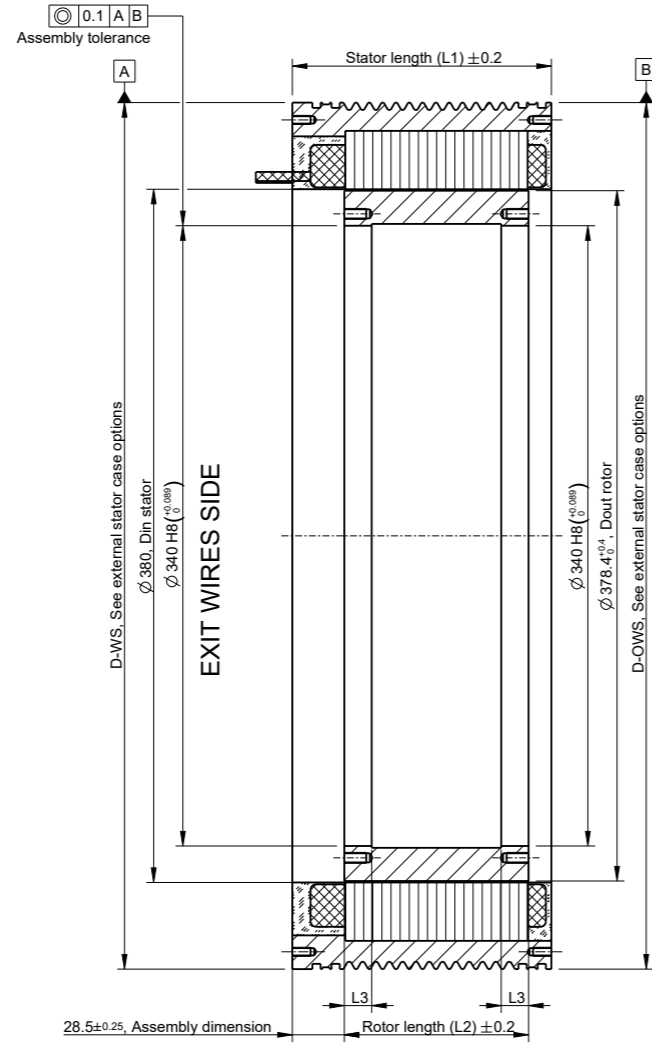
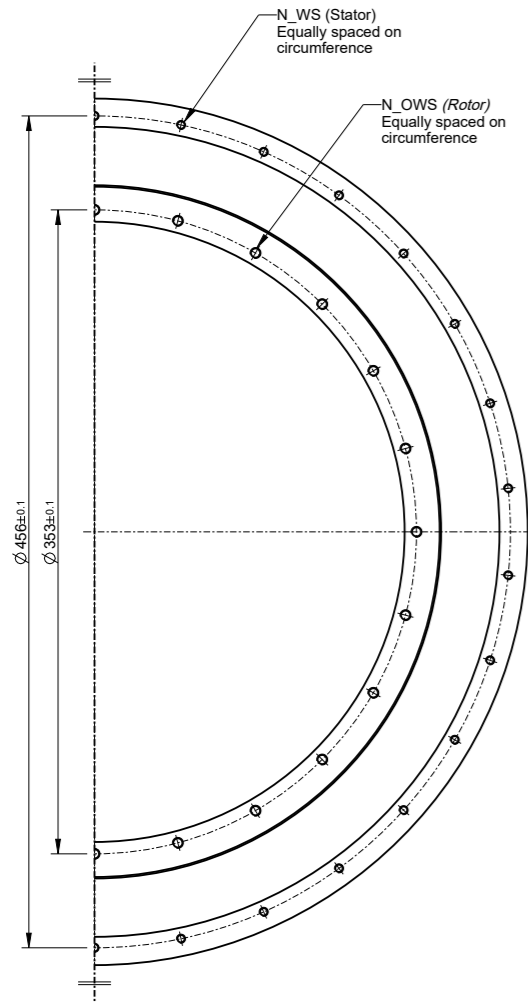

Rotor size TKHRT	ROTOR FIXING HOLES			Rotor dimensions	
	N_WS (min class)	N_OWS (min class)	b° (angular pitch)	L2 (Rotor length)	L3 (Centering length)
TKHRT 445 50	12 x M6 (8.8)	12 x M6 (8.8)	30°	51	10
TKHRT 445 100	24 x M6 (8.8)	24 x M6 (8.8)	15°	101	15
TKHRT 445 150	24 x M8 (8.8)	24 x M8 (8.8)	15°	151	15
TKHRT 445 200	30 x M8 (8.8)	30 x M8 (8.8)	12°	201	20

Stator size TKHST	Stator fixing holes			Stator Length
	N°_WS (min class)	N°_OWS (min class)	a° (angular pitch)	L1
TKHST 445 50	18 x M5 (8.8)	18 x M5 (8.8)	20°	92
TKHST 445 100	30 x M5 (8.8)	30 x M5 (8.8)	12°	142
TKHST 445 150	30 x M6 (8.8)	30 x M6 (8.8)	12°	192
TKHST 445 200	24 x M8 (8.8)	24 x M8 (8.8)	15°	242

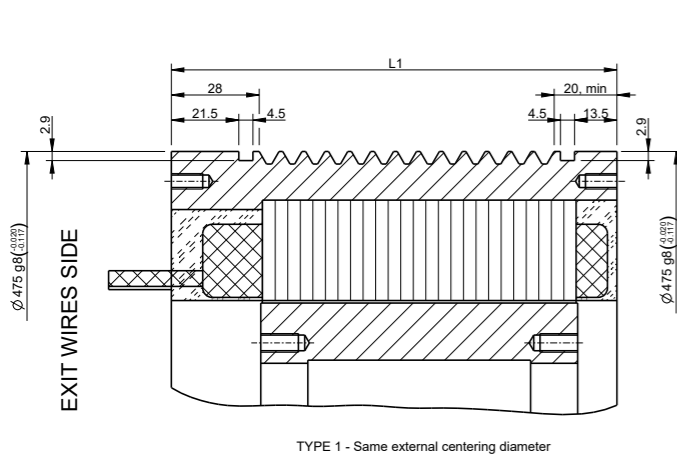

TYPE 1 - Same external centering diameter

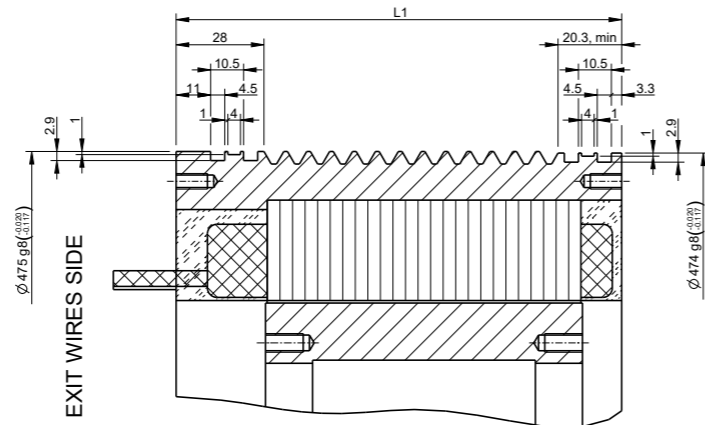

TYPE 2 - Bigger external centering on WS

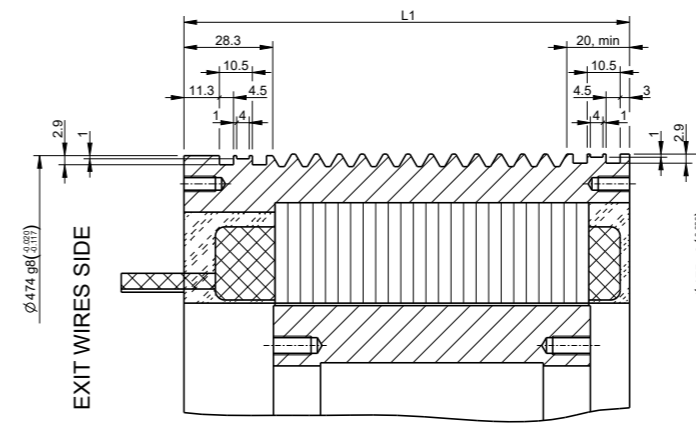

TYPE 3 - Bigger external centering on OWS

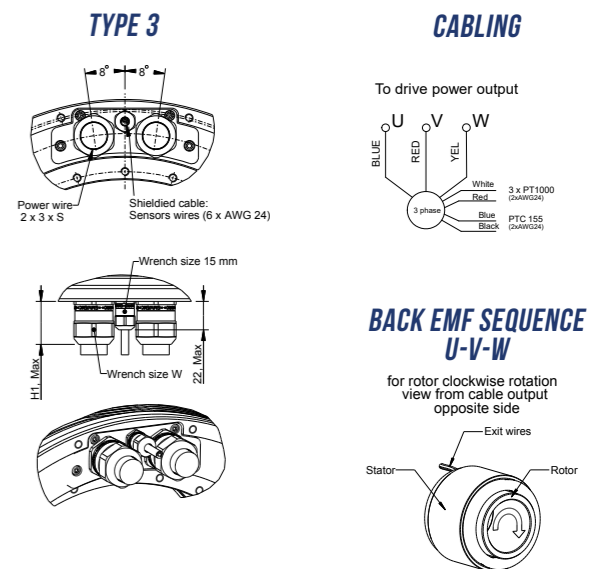
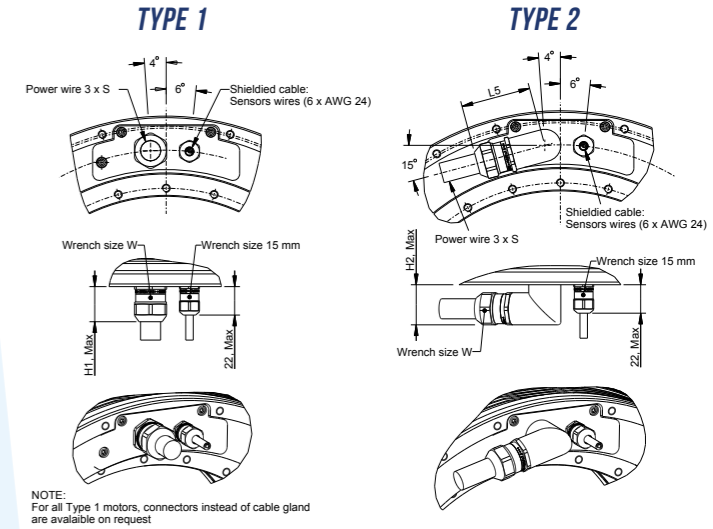

		050-29	050-44	050-88	100-29	100-58	100-88	150-44	150-88	150-132	200-58	200-117
Rated Torque	Nm	1150	1160	1160	2460	2470	2470	3770	3770	3770	5110	5110
Knee Speed	rpm	170	105	42	165	75	45	107	45	24	75	30
Rated Power	kW	20,5	12,8	5,1	42,5	19,4	11,6	42,2	17,8	9,5	40,1	16,1
Rated Current	A	43,2	29,0	14,5	93,1	46,7	31,1	95,3	47,6	31,7	97,2	48,5
Torque Constant	Nm/A	29,41	44,12	88,24	29,41	58,83	88,24	44,12	88,24	132,36	58,83	117,65
Peak Torque	Nm	1900	1910	1910	3830	3840	3840	5760	5760	5760	7680	7680
Peak Current	A	83,7	56,0	27,9	167,7	84,0	56,0	167,9	83,9	55,9	167,8	83,9
S6 Torque	① Nm	1659	1659	1659	3473	3473	3473	5357	5357	5357	7143	7143
Rated Torque at 0 rpm	Nm	854	854	854	1821	1821	1821	2789	2789	2789	3754	3754
Max Continuous Speed	② rpm	280	280	280	280	280	280	280	280	280	280	280
Max Transient Speed	rpm	420	420	420	420	420	420	420	420	420	420	420
Motor Constant	Nm/√W	23,75	23,75	23,75	37,39	37,39	37,39	47,74	47,74	47,74	56,36	56,36
Number of Poles	-	84	84	84	84	84	84	84	84	84	84	84
Back EMF Constant	③ V*s	16,98	25,47	50,95	16,98	33,96	50,95	25,47	50,95	76,42	33,96	67,93
Thermal Time Constant	s	259,6	258,5	257,0	228,2	226,9	226,3	217,0	216,2	215,8	211,5	210,8
Min Coolant Flow	④ l/min	6,8	6,7	6,7	12,6	12,5	12,5	18,2	18,1	18,1	23,7	23,7
Motor Losses	⑤ kW	4,2	4,2	4,2	7,8	7,8	7,8	11,3	11,3	11,3	14,7	14,7
Rotor Inertia	kg*m ²	0,29	0,29	0,29	0,51	0,51	0,51	0,73	0,73	0,73	0,96	0,96
Rotor Mass	kg	4,6	4,6	4,6	9,2	9,2	9,2	13,7	13,7	13,7	18,2	18,2
Stator Mass	kg	36	36	36	60	60	60	84	84	84	108	108

TEST CONDITIONS

- ① 40% duty, 60s cycle
- ② for higher continuous speed refer to TKH high-speed version
- ③ at 20°C
- ④ Δt 10°C
- ⑤ at 1 rpm

*For higher speed solutions,
we have available TKH - HIGH SPEED version.
Please, contact our Technical Support Team
(support@phase.eu)
to find the best solution for your requirements.*



TORQUE SPEED DIAGRAM

TKH 525.050.29

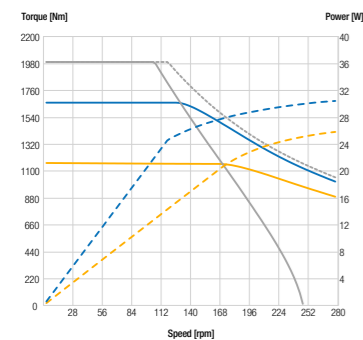

TKH 525.050.44

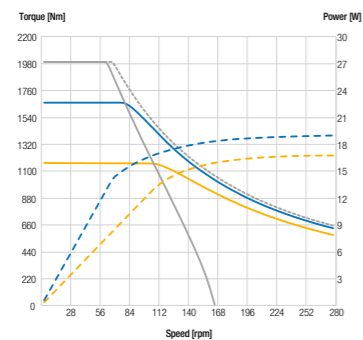

TKH 525.050.88

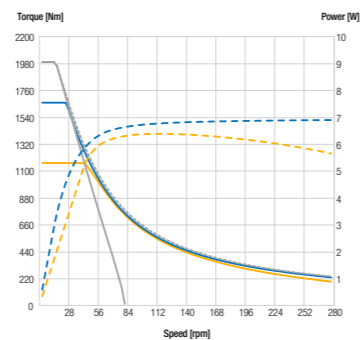

TKH 525.150.44

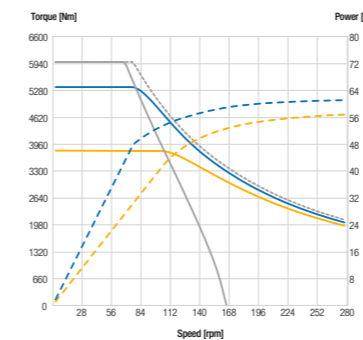

TKH 525.150.88

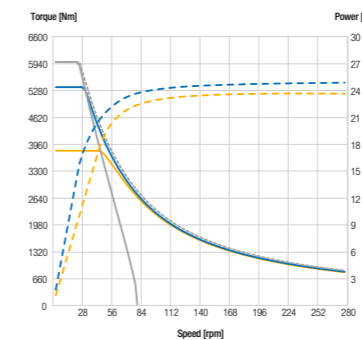

TKH 525.150.132

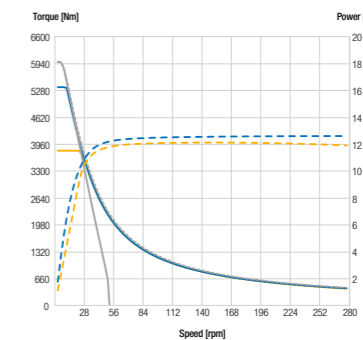

TKH 525.100.29

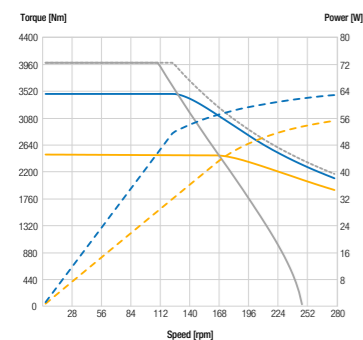

TKH 525.100.58

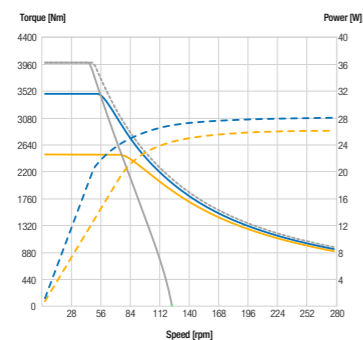

TKH 525.100.88

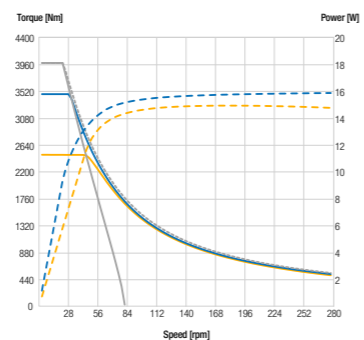

TKH 525.200.58

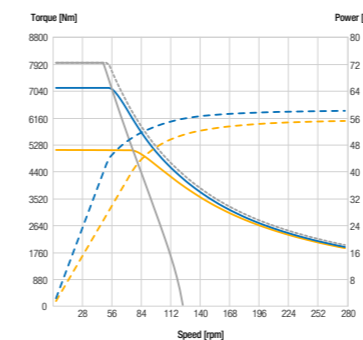

TKH 525.200.117

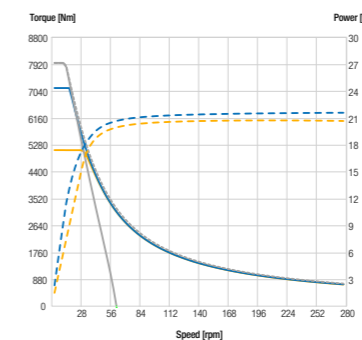

- S1 torque
- S6 torque, duty%
- Voltage saturation limit
- - - Saturation torque
- - - S1 power
- - - Peak power

We offer the flexibility to customize mechanical interfaces to suit your individual application needs, ensuring a seamless plug-and-play experience.

TECHNICAL DRAWING TKH 525

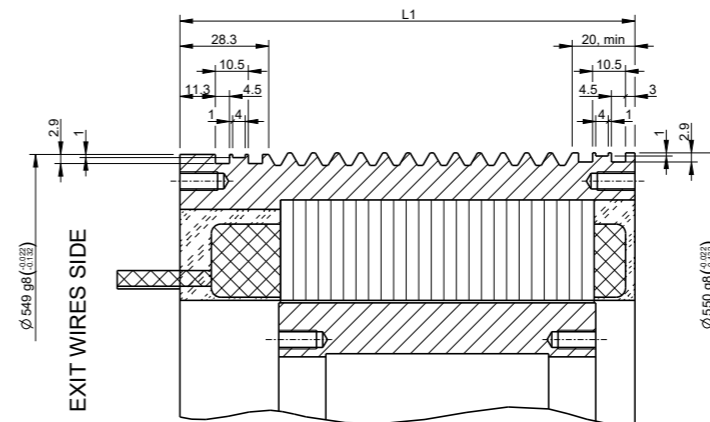
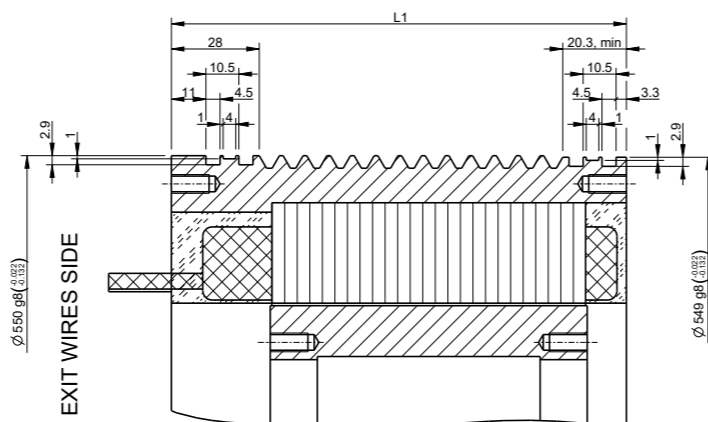
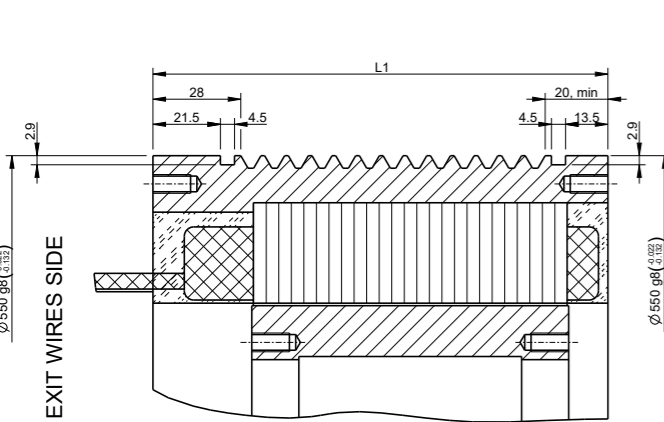
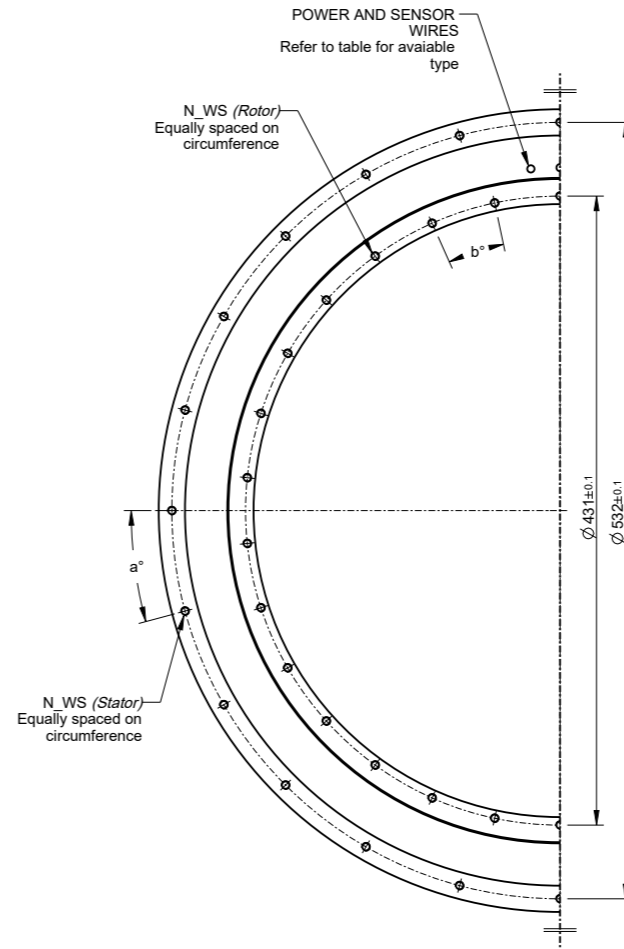
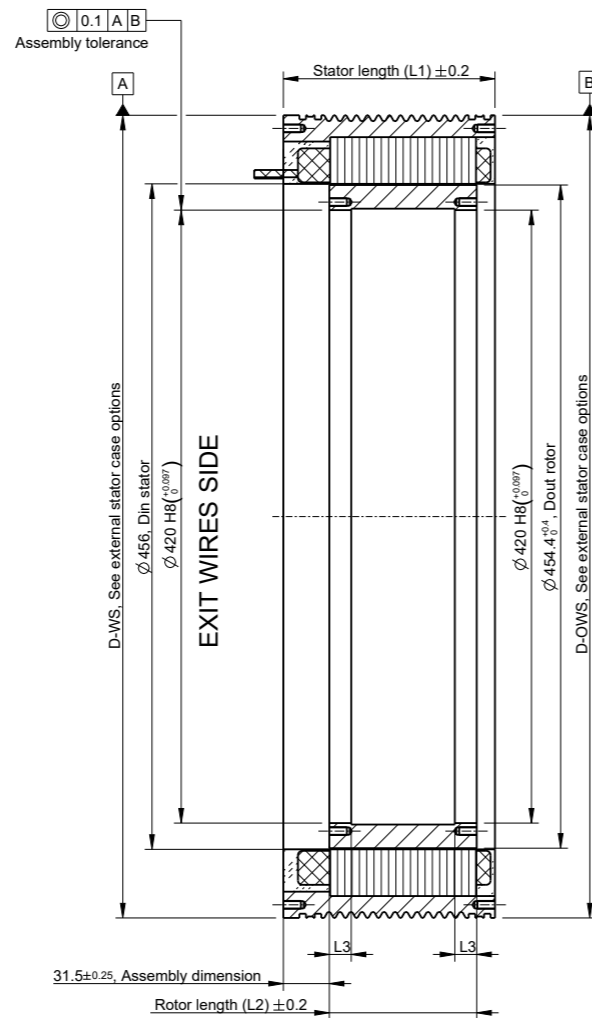
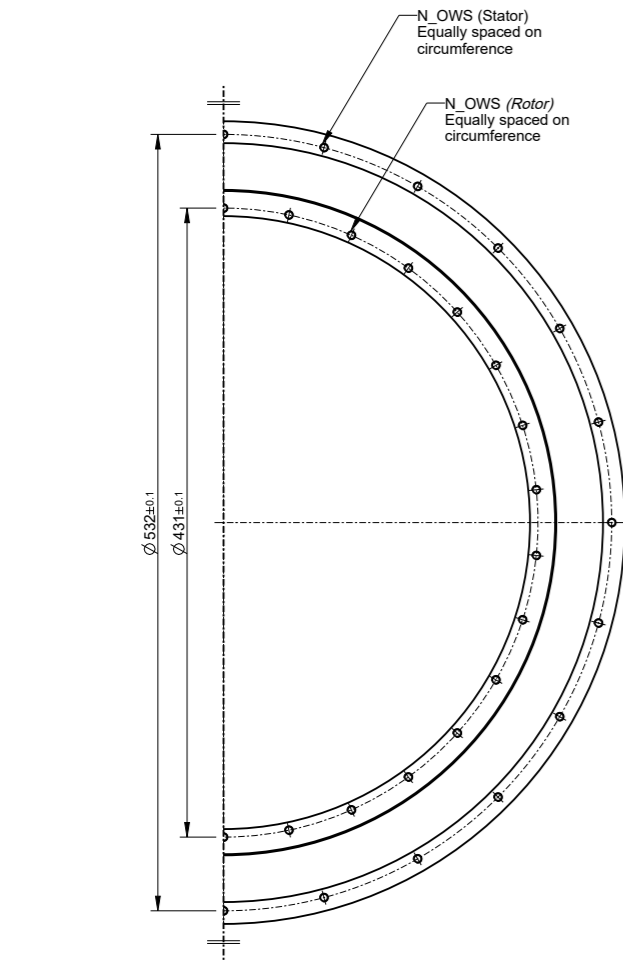

Rotor size TKHRT	Rotor fixing holes			Rotor dimensions	
	N_WS (min class)	N_OWS (min class)	b° (angular pitch)	L2 (Rotor length)	L3 (Centering length)
TKHRT 525 50	18 x M6 (8.8)	18 x M6 (8.8)	20°	51	20
TKHRT 525 100	30 x M6 (8.8)	30 x M6 (8.8)	12°	101	12
TKHRT 525 150	24 x M8 (8.8)	24 x M8 (8.8)	15°	151	15
TKHRT 525 200	36 x M8 (8.8)	36 x M8 (8.8)	10°	201	10

Stator size TKHST	Stator fixing holes			Stator Length
	N° WS (min class)	N° OWS (min class)	a° (angular pitch)	L1
TKHST 525 50	18 x M5 (8.8)	18 x M5 (8.8)	20°	95
TKHST 525 100	24 x M6 (8.8)	24 x M6 (8.8)	15°	145
TKHST 525 150	36 x M6 (8.8)	36 x M6 (8.8)	10°	195
TKHST 525 200	30 x M8 (8.8)	30 x M8 (8.8)	12°	245

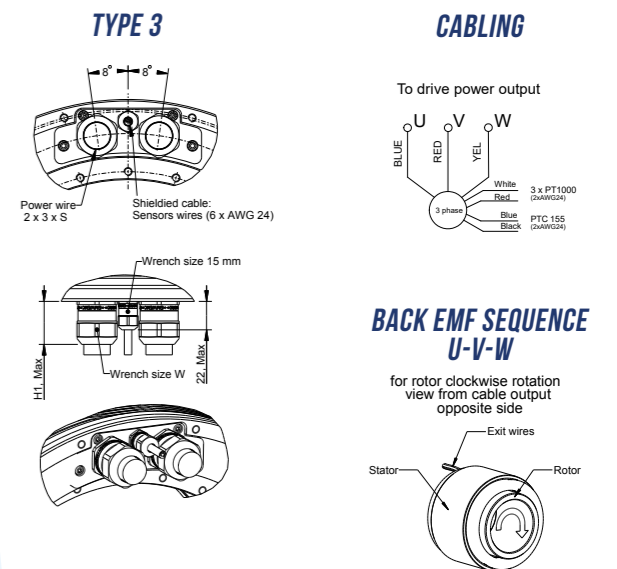
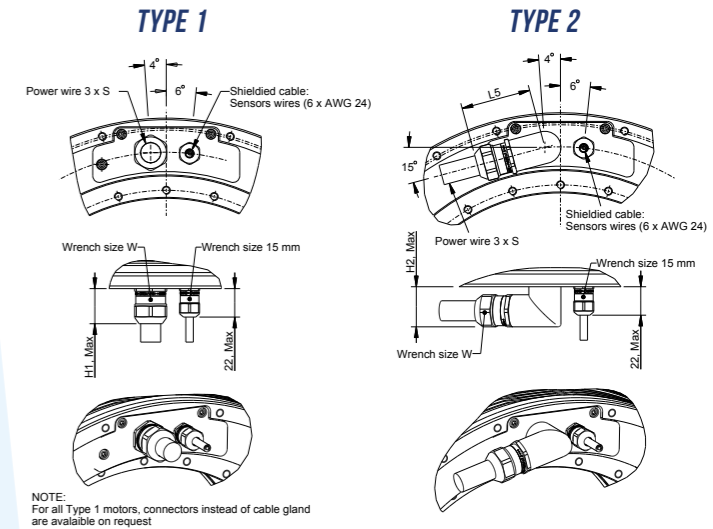

		050-59	050-119	100-34	100-119	150-51	200-68
Rated Torque	Nm	1580	1580	3370	3370	5140	6950
Knee Speed	rpm	75	28	140	30	92	65
Rated Power	kW	12,4	4,6	49,4	10,6	49,5	47,3
Rated Current	A	28,9	14,4	108,8	31,0	110,7	112,5
Torque Constant	Nm/A	59,57	119,15	34,04	11,92	51,06	68,09
Peak Torque	Nm	2560	2570	5140	5150	7720	10300
Peak Current	A	54,3	27,2	190,2	54,4	190,1	190,1
S6 Torque	① Nm	2268	2268	4751	4751	7184	9730
Rated Torque at 0 rpm	Nm	1163	1163	2481	2481	3801	5116
Max Continuous Speed	② rpm	240	240	240	240	240	240
Max Transient Speed	rpm	360	360	360	360	360	360
Motor Constant	Nm/√W	29,69	29,69	46,75	46,75	59,68	70,46
Number of Poles	-	98	98	98	98	98	98
Back EMF Constant	③ V*s	34,40	68,79	19,65	68,79	29,48	39,31
Thermal Time Constant	s	259,0	257,6	229,3	227,0	218,0	212,4
Min Coolant Flow	④ l/min	7,7	7,7	14,5	14,4	20,9	27,3
Motor Losses	⑤ kW	4,8	4,8	9,0	9,0	13,0	17,0
Rotor Inertia	kg*m ²	0,44	0,44	0,79	0,79	1,13	1,48
Rotor Mass	kg	5,2	5,2	10,3	10,3	15,4	20,5
Stator Mass	kg	41	41	69	69	98	125

TEST CONDITIONS

- ① 40% duty, 60s cycle
- ② for higher continuous speed refer to TKH high-speed version
- ③ at 20°C
- ④ Δt 10°C
- ⑤ at 1 rpm

*For higher speed solutions,
we have available TKH - HIGH SPEED version.
Please, contact our Technical Support Team
(support@phase.eu)
to find the best solution for your requirements.*



TORQUE SPEED DIAGRAM

TKH 595.050.59

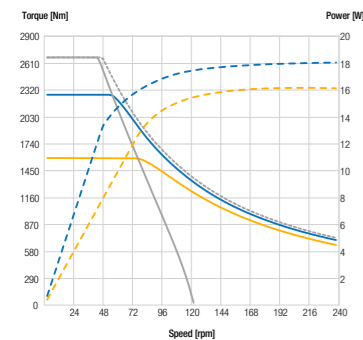

TKH 595.050.119

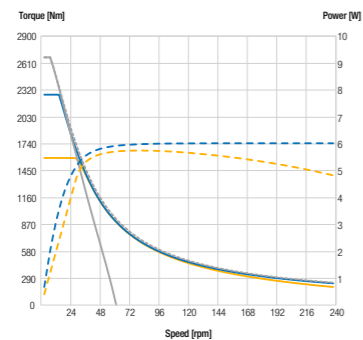

TKH 595.150.51

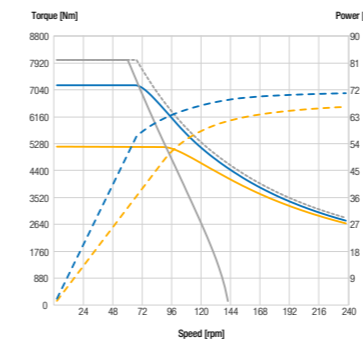

TKH 595.100.34

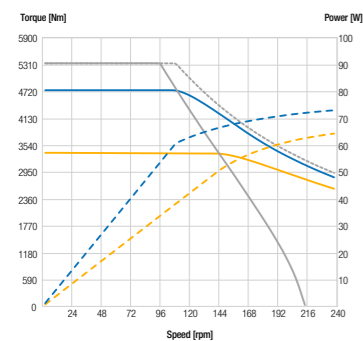

TKH 595.100.119

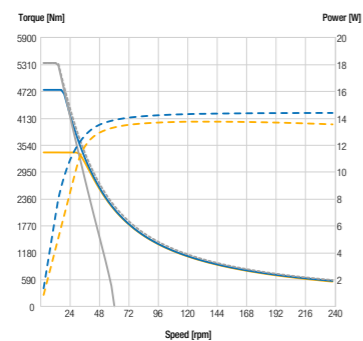

TKH 595.200.68

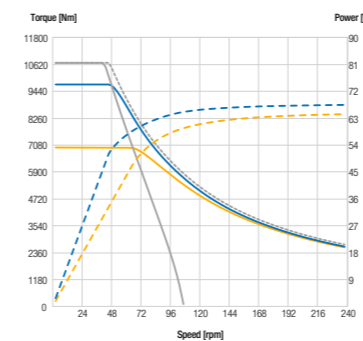

- S1 torque
- S6 torque, duty%
- Voltage saturation limit
- - - Saturation torque
- - - S1 power
- - - Peak power

We offer the flexibility to customize mechanical interfaces to suit your individual application needs, ensuring a seamless plug-and-play experience.

TECHNICAL DRAWING TKH 595

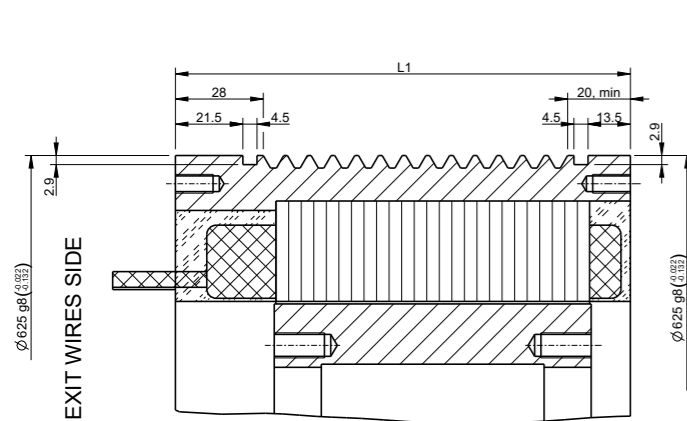
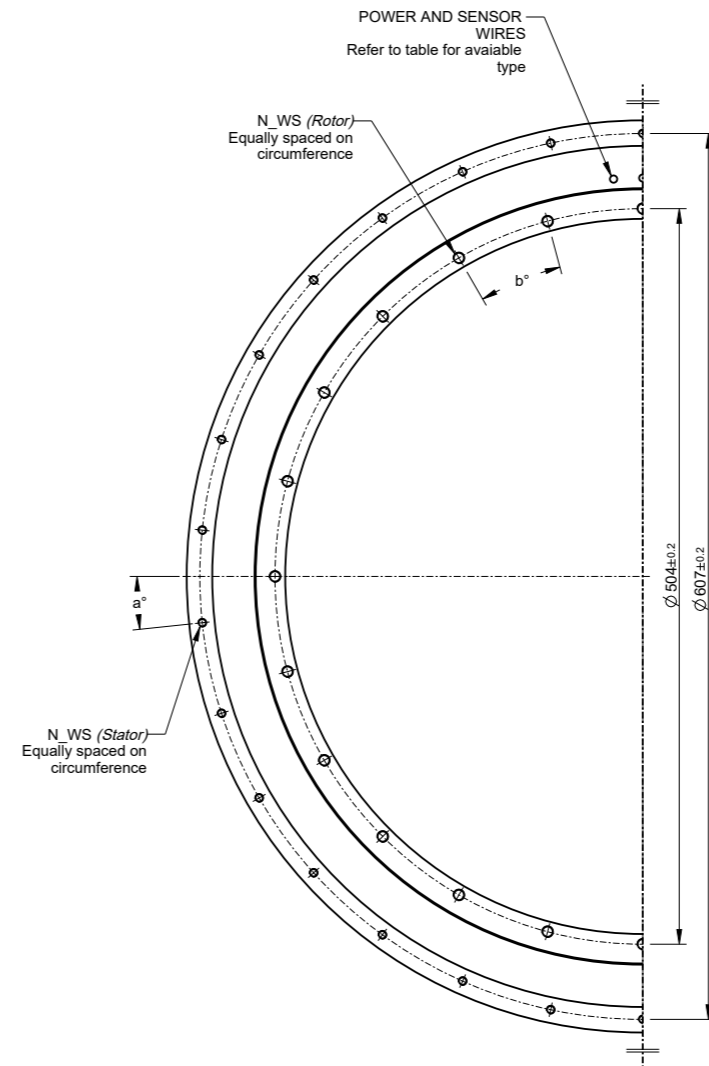
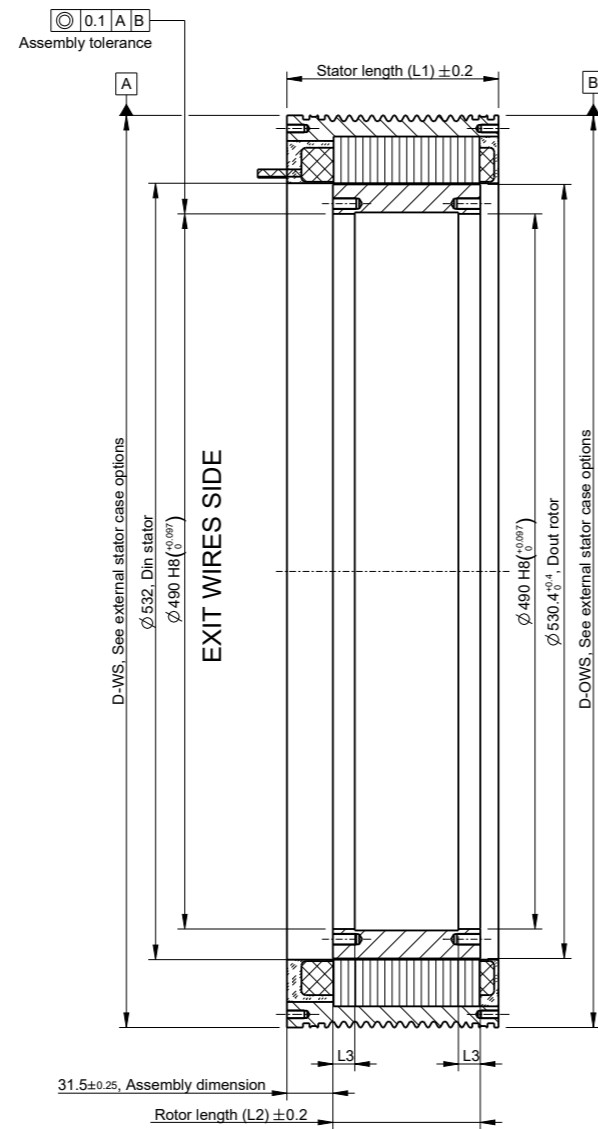
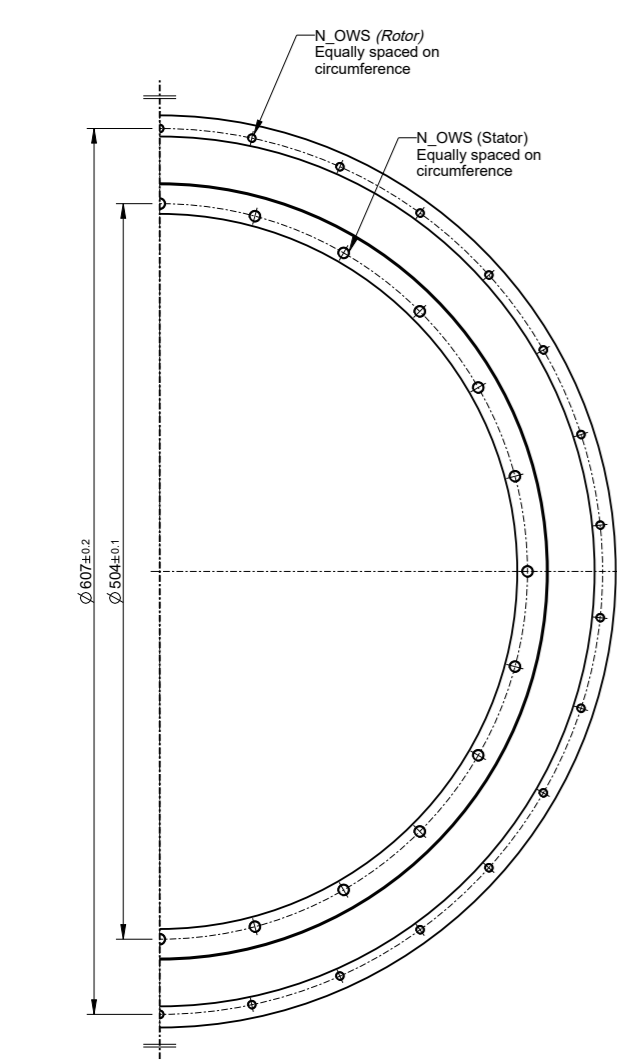

TYPE 1 - Same external centering diameter

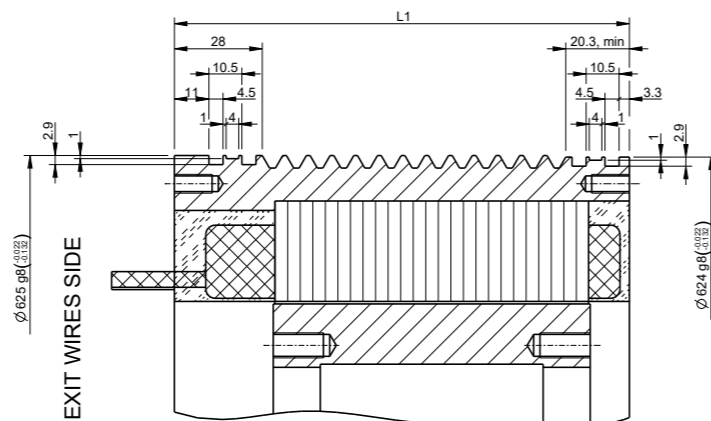

TYPE 2 - Bigger external centering on WS

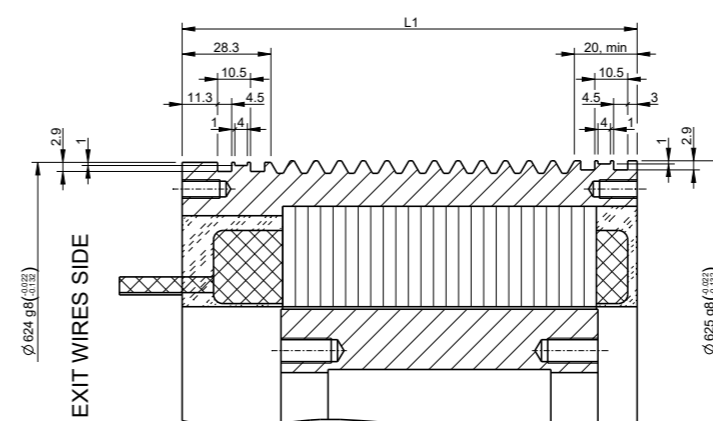

TYPE 3 - Bigger external centering on OWS

Rotor size TKHRT	Rotor fixing holes			Rotor dimensions	
	N_WS (min class)	N_OWS (min class)	b° (angular pitch)	L2 (Rotor length)	L3 (Centering length)
TKHRT 595 50	12 x M8 (8.8)	12 x M8 (8.8)	30°	51	10
TKHRT 595 100	24 x M8 (8.8)	24 x M8 (8.8)	15°	101	15
TKHRT 595 150	30 x M8 (8.8)	30 x M8 (8.8)	12°	151	15
TKHRT 595 200	24 x M10 (8.8)	24 x M10 (8.8)	15°	201	20

Stator size TKHST	Stator fixing holes			Stator Length
	N° WS (min class)	N° OWS (min class)	a° (angular pitch)	L1
TKHST 595 50	24 x M5 (8.8)	24 x M5 (8.8)	15°	95
TKHST 595 100	30 x M6 (8.8)	30 x M6 (8.8)	12°	145
TKHST 595 150	24 x M8 (8.8)	24 x M8 (8.8)	15°	195
TKHST 595 200	30 x M8 (8.8)	30 x M8 (8.8)	12°	245

TYPE 1

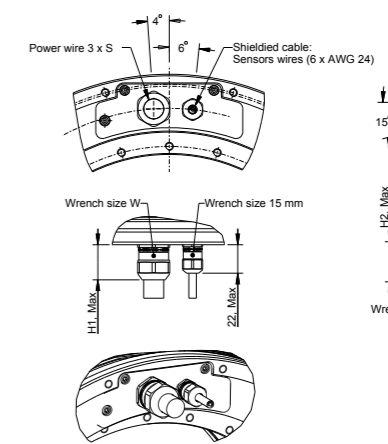

NOTE:
For all Type 1 motors, connectors instead of cable gland are available on request

TYPE 2

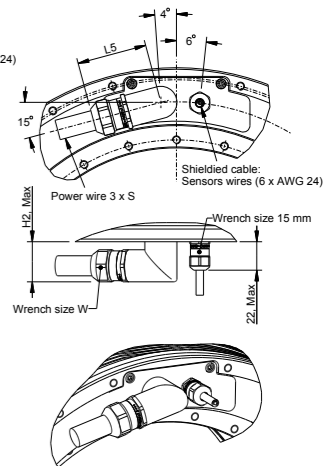

TYPE 3

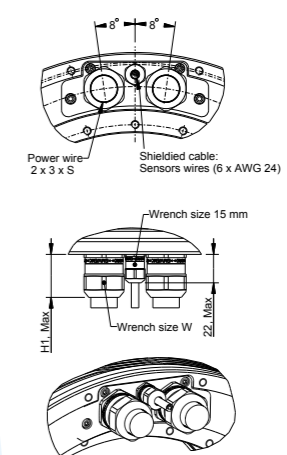

CABLING

To drive power output

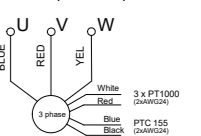

BACK EMF SEQUENCE U-V-W

for rotor clockwise rotation view from cable output opposite side

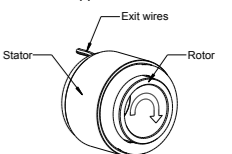

		050-38	050-77	100-38	100-77	150-58	150-116	200-77	200-155
Rated Torque	Nm	2030	2030	4360	4370	6690	6690	9000	9000
Knee Speed	rpm	128	55	125	55	80	33	57	22
Rated Power	kW	27,2	11,7	57,1	25,2	56,1	23,1	53,7	20,7
Rated Current	A	57,0	28,4	123,4	61,8	126,5	63,2	127,8	63,9
Torque Constant	Nm/A	38,96	77,93	38,96	77,93	58,45	116,89	77,93	155,86
Peak Torque	Nm	3380	3380	6815	6820	10240	10240	13660	13660
Peak Current	A	111,8	55,5	223,7	111,9	224,0	111,9	224,0	74,8
S6 Torque	① Nm	2950	2950	6132	6132	9399	9399	12532	12532
Rated Torque at 0 rpm	Nm	1512	1512	3223	3223	4938	4938	6647	6647
Max Continuous Speed	② rpm	210	210	210	210	210	210	210	210
Max Transient Speed	rpm	320	320	320	320	320	320	320	320
Motor Constant	Nm/√W	36,34	36,34	57,20	57,20	73,03	73,03	86,22	86,22
Number of Poles	-	112	112	112	112	112	112	112	112
Back EMF Constant	③ V*s	22,50	44,99	22,50	44,99	33,74	67,49	44,99	89,98
Thermal Time Constant	s	261,6	259,5	230,1	228,6	218,8	217,8	213,1	212,4
Min Coolant Flow	④ l/min	9,0	8,8	16,5	16,4	23,9	23,8	31,1	31,1
Motor Losses	⑤ kW	5,4	5,4	10,2	10,2	14,8	14,8	19,3	19,3
Rotor Inertia	kg*m ²	0,73	0,73	1,30	1,30	1,88	1,88	2,45	2,45
Rotor Mass	kg	6,6	6,6	13,0	13,0	19,5	19,5	25,9	25,9
Stator Mass	kg	48	48	80	80	111	111	142	142

TEST CONDITIONS

- ① 40% duty, 60s cycle
- ② for higher continuous speed refer to TKH high-speed version
- ③ at 20°C
- ④ Δt 10°C
- ⑤ at 1 rpm

For higher speed solutions,
we have available TKH - HIGH SPEED version.
Please, contact our Technical Support Team
(support@phase.eu)
to find the best solution for your requirements.



TORQUE SPEED DIAGRAM

TKH 675.050.38

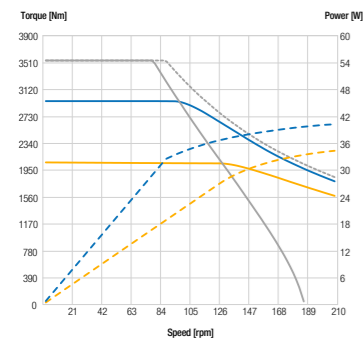

TKH 675.050.77

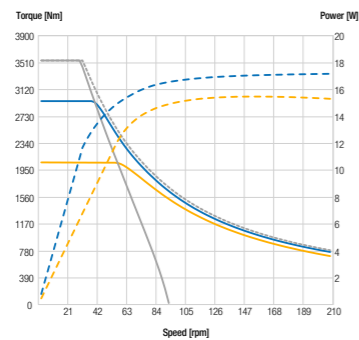

TKH 675.150.58

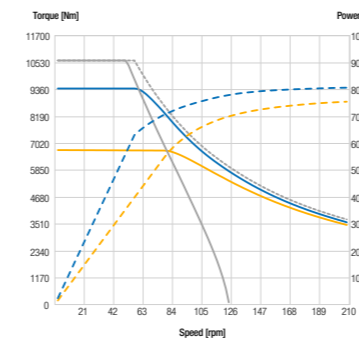

TKH 675.150.116

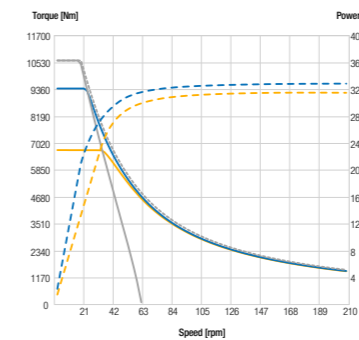

TKH 675.100.38

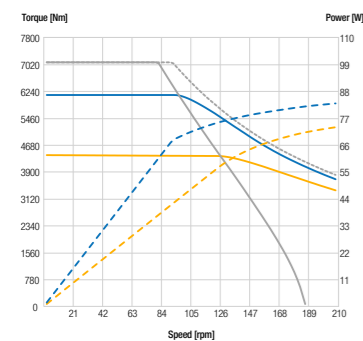

TKH 675.100.77

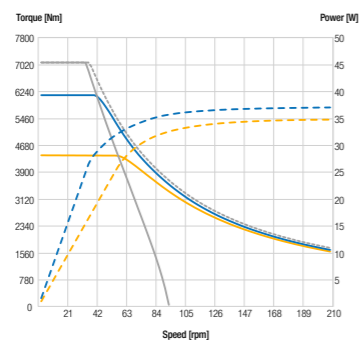

TKH 675.200.77

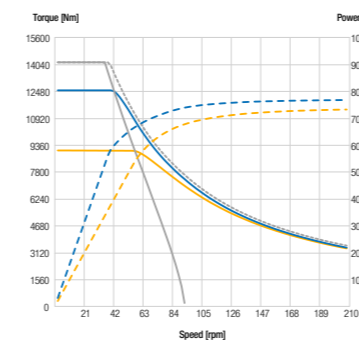

TKH 675.200.155

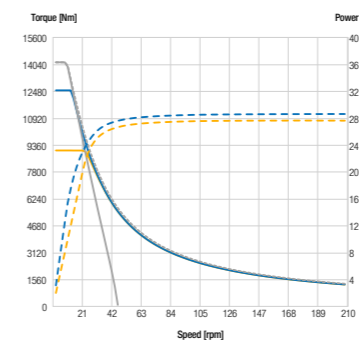

- S1 torque
- S6 torque, duty%
- Voltage saturation limit
- Saturation torque
- S1 power
- Peak power

We offer the flexibility to customize mechanical interfaces to suit your individual application needs, ensuring a seamless plug-and-play experience.

TECHNICAL DRAWING TKH 675

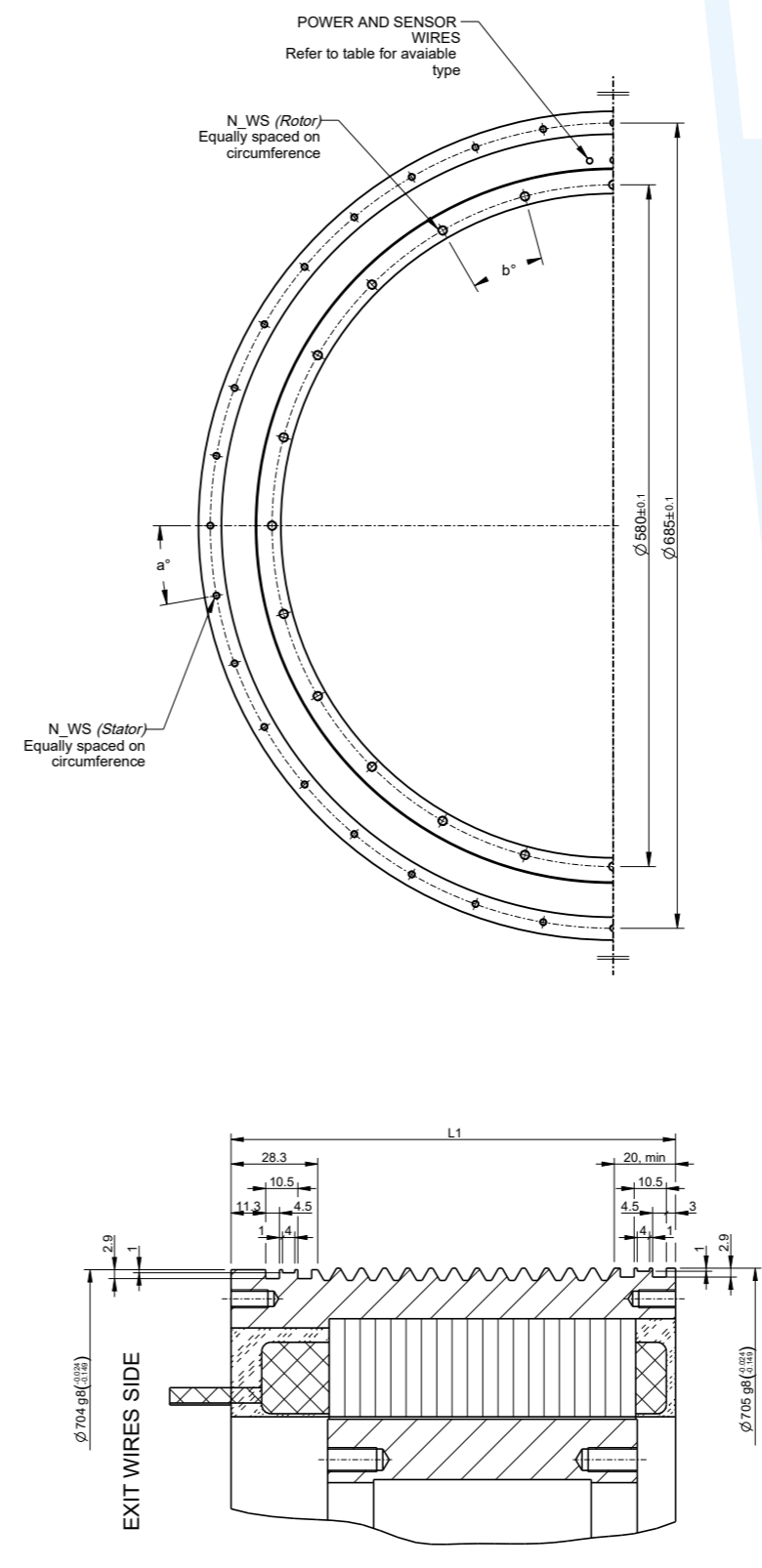
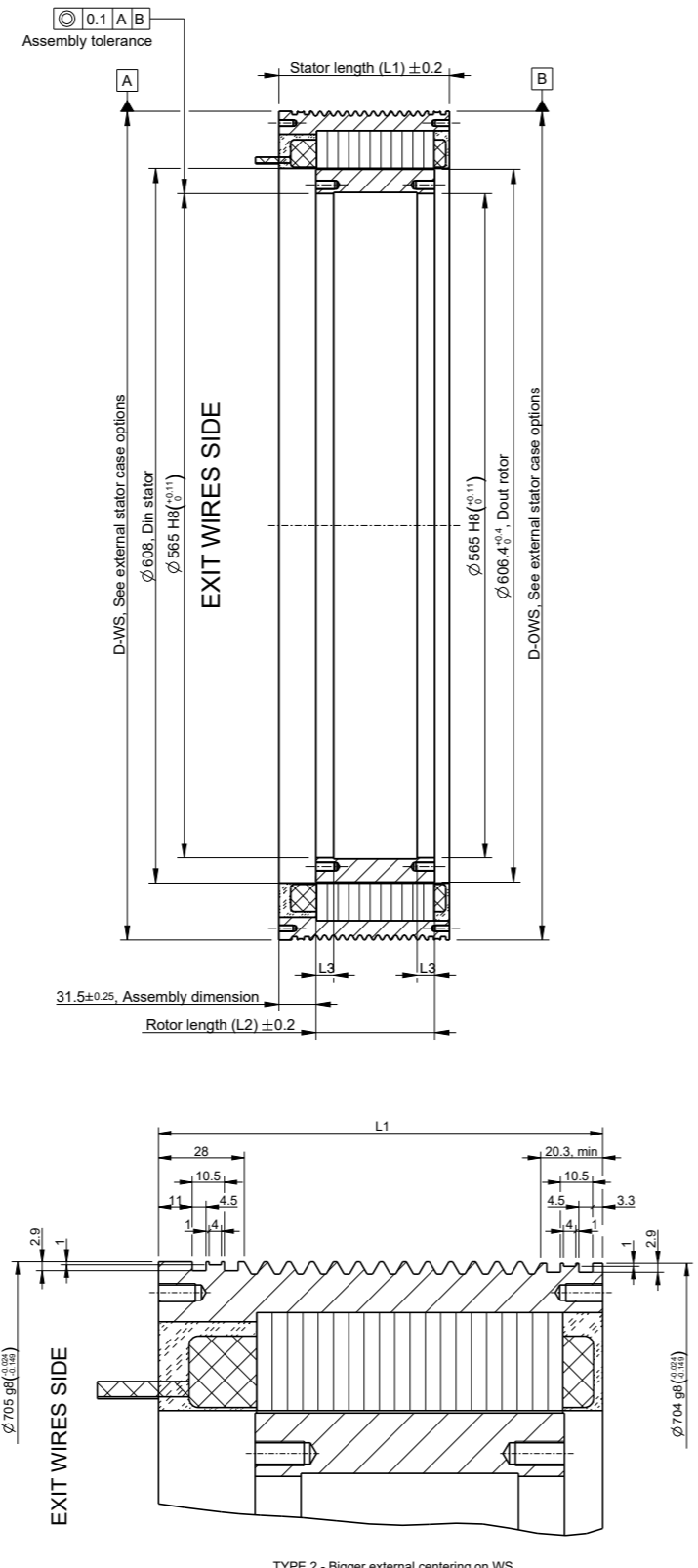
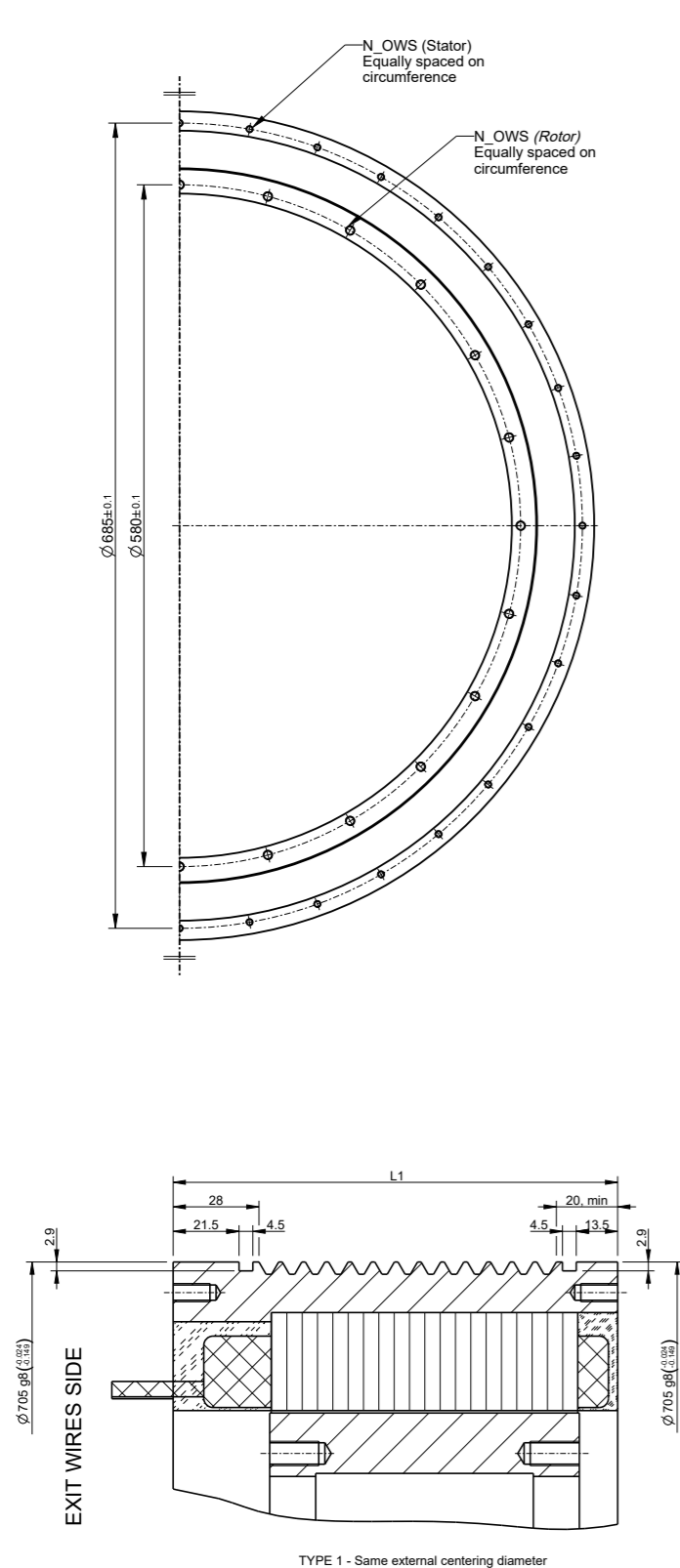

Rotor size TKHRT	Rotor fixing holes			Rotor dimensions	
	N_WS (min class)	N_OWS (min class)	b° (angular pitch)	L2 (Rotor length)	L3 (Centering length)
TKHRT 675 50	12 x M8 (8.8)	12 x M8 (8.8)	30°	51	10
TKHRT 675 100	24 x M8 (8.8)	24 x M8 (8.8)	15°	101	15
TKHRT 675 150	24 x M10 (8.8)	24 x M10 (8.8)	15°	151	15
TKHRT 675 200	30 x M10 (8.8)	30 x M10 (8.8)	12°	201	20

Stator size TKHST	Stator fixing holes			Stator Length L1
	N°_WS (min class)	N°_OWS (min class)	a° (angular pitch)	
TKHST 675 50	18 x M6 (8.8)	18 x M6 (8.8)	20°	95
TKHST 675 100	36 x M6 (8.8)	36 x M6 (8.8)	10°	145
TKHST 675 150	30 x M8 (8.8)	30 x M8 (8.8)	12°	195
TKHST 675 200	36 x M8 (8.8)	36 x M8 (8.8)	10°	245

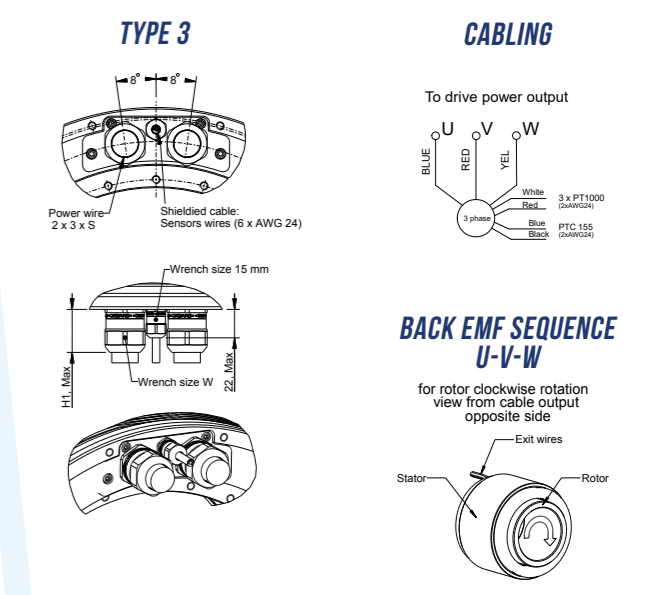
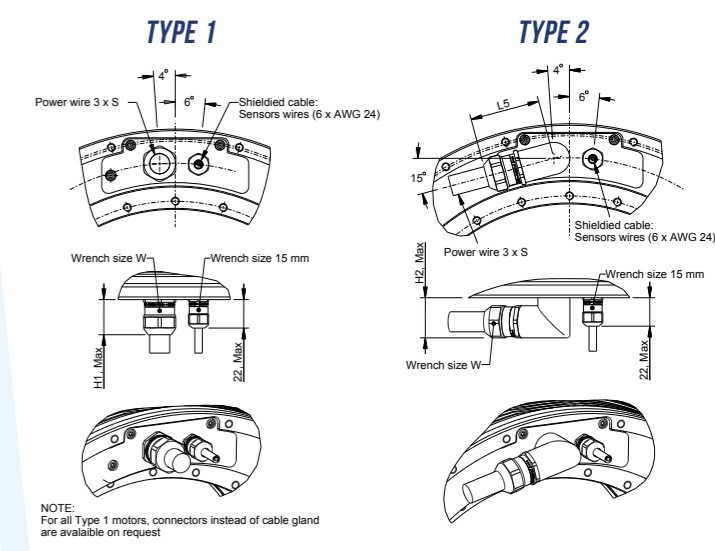

		050-32	050-65	050-97	100-43	100-65	100-130	150-65	150-97	200-87	200-130
Rated Torque	Nm	2550	2580	2580	5510	5510	5510	8470	8470	11420	11420
Knee Speed	rpm	155	70	42	110	70	30	70	43	50	30
Rated Power	kW	41,4	18,9	11,4	63,5	40,4	17,3	62,1	38,1	59,8	35,9
Rated Current	A	84,9	42,8	28,5	138,2	92,0	46,0	142,1	94,7	143,9	95,9
Torque Constant	Nm/A	32,65	65,31	97,96	43,54	65,31	130,62	65,31	97,96	87,08	130,62
Peak Torque	Nm	4200	4230	4240	8500	8500	8510	12770	12770	17000	17000
Peak Current	A	163,7	82,0	54,7	246,3	164,0	82,0	246,2	164,1	245,5	163,6
S6 Torque	① Nm	3738	3738	3738	7821	7821	7821	11787	11787	15936	15936
Rated Torque at 0 rpm	Nm	1911	1911	1911	4077	4077	4077	6247	6247	8409	8409
Max Continuous Speed	② rpm	200	200	200	200	200	200	200	200	200	200
Max Transient Speed	rpm	300	300	300	300	300	300	300	300	300	300
Motor Constant	Nm/√W	43,07	43,07	43,07	67,80	67,80	67,80	86,56	86,56	102,18	102,18
Number of Poles	-	126	126	126	126	126	126	126	126	126	126
Back EMF Constant	③ V*s	18,85	37,71	56,56	25,15	37,71	75,41	37,71	56,56	50,27	75,41
Thermal Time Constant	s	263,6	261,0	259,9	230,9	229,9	228,6	219,4	218,8	213,8	213,2
Min Coolant Flow	④ l/min	10,2	9,9	9,8	18,5	18,4	18,3	26,7	26,6	34,8	34,8
Motor Losses	⑤ kW	6,1	6,1	6,1	11,4	11,4	11,4	16,5	16,5	21,6	21,6
Rotor Inertia	kg*m ²	0,993	0,993	0,993	1,77	1,77	1,77	2,54	2,54	3,32	3,32
Rotor Mass	kg	7,0	7,0	7,0	13,9	13,9	13,9	20,7	20,7	27,6	27,6
Stator Mass	kg	54	54	54	89	89	89	124	124	159	159

TEST CONDITIONS

- ① 40% duty, 60s cycle
- ② for higher continuous speed refer to TKH high-speed version
- ③ at 20°C
- ④ Δt 10°C
- ⑤ at 1 rpm

*For higher speed solutions,
we have available TKH - HIGH SPEED version.
Please, contact our Technical Support Team
(support@phase.eu)
to find the best solution for your requirements.*



TORQUE SPEED DIAGRAM

TKH 745.050.32

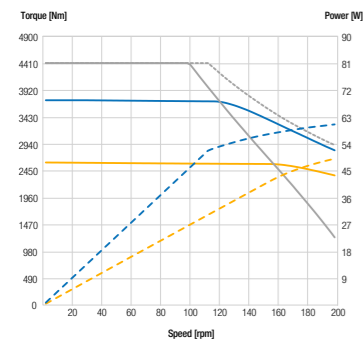

TKH 745.050.65

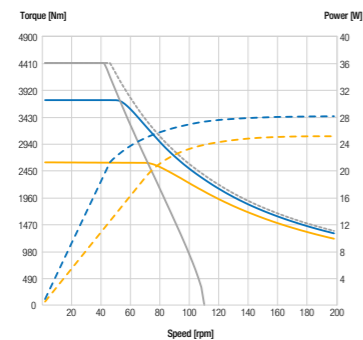

TKH 745.050.97

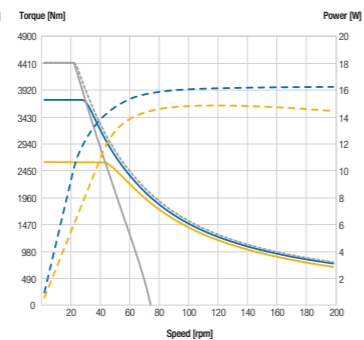

TKH 745.150.65

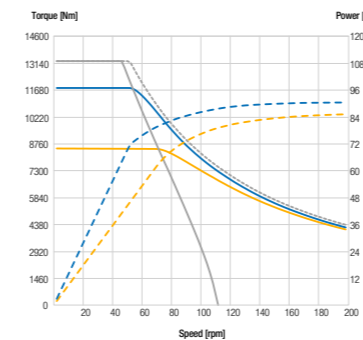

TKH 745.150.97

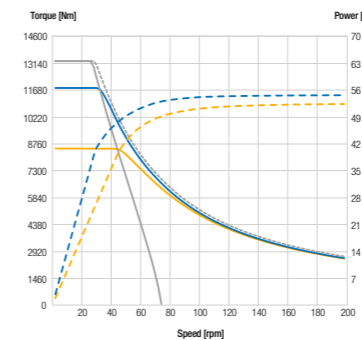

TKH 745.100.43

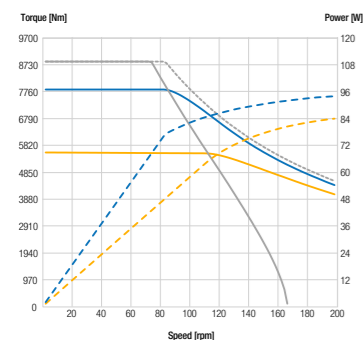

TKH 745.100.65

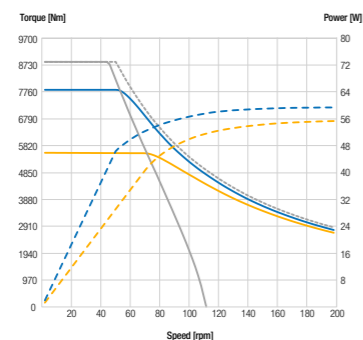

TKH 745.100.130

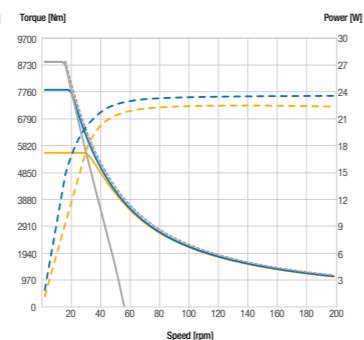

TKH 745.200.87

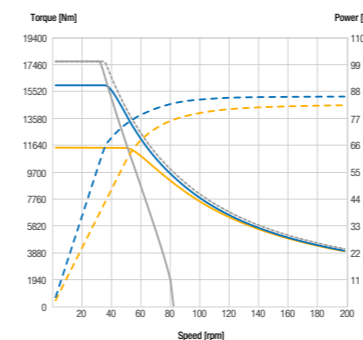

TKH 745.200.130

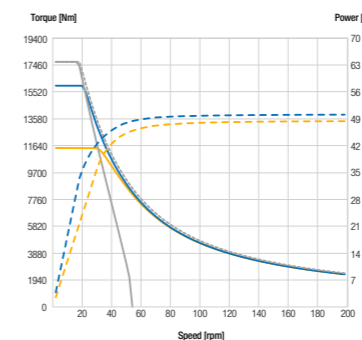

- S1 torque
- S6 torque, duty%
- Voltage saturation limit
- Saturation torque
- S1 power
- Peak power

We offer the flexibility to customize mechanical interfaces to suit your individual application needs, ensuring a seamless plug-and-play experience.

TECHNICAL DRAWING TKH 745

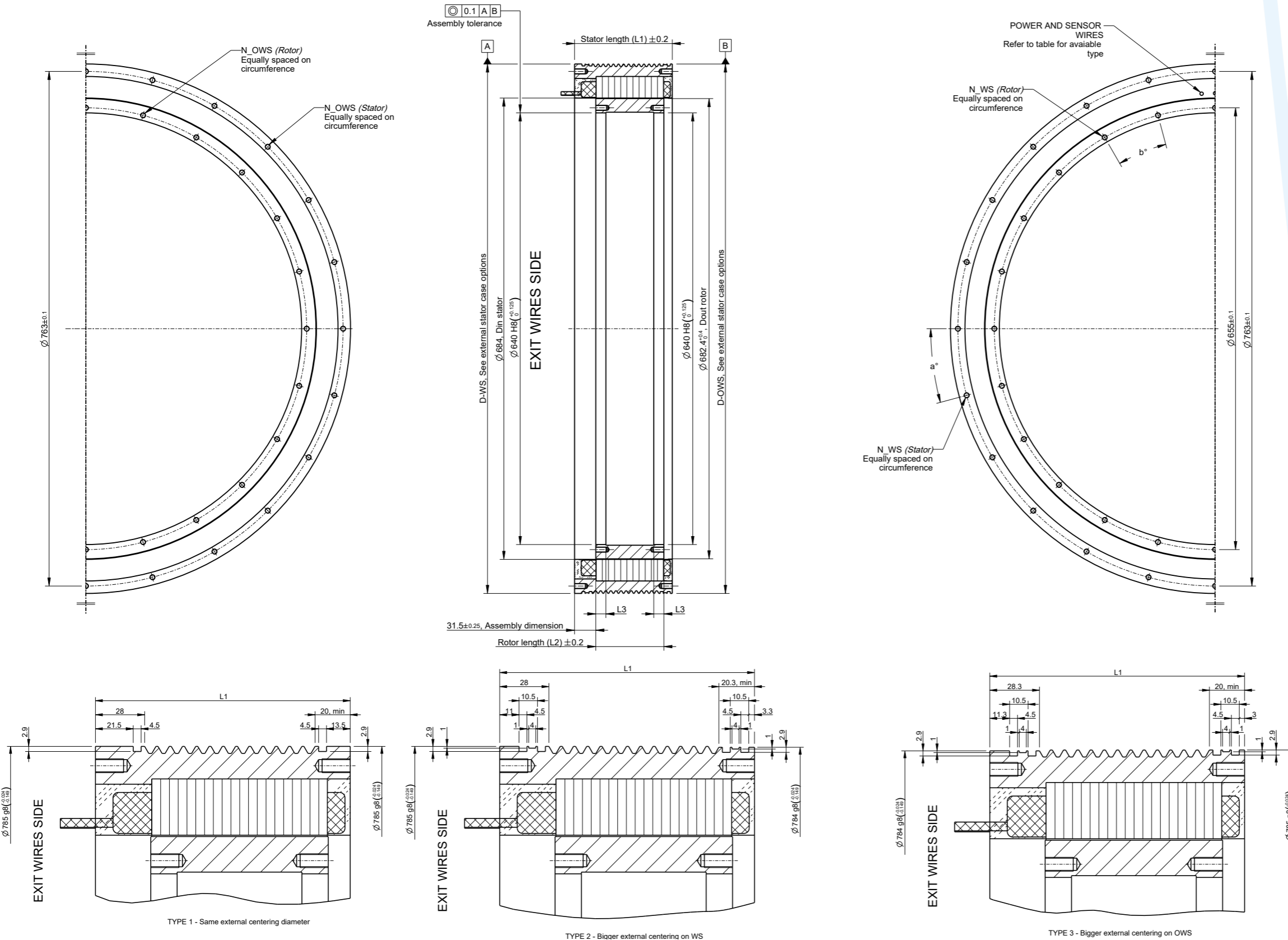

Rotor size TKHRT	Rotor fixing holes			Rotor dimensions	
	N_WS (min class)	N_OWS (min class)	b° (angular pitch)	L2 (Rotor length)	L3 (Centering length)
TKHRT 745 50	12 x M8 (8.8)	12 x M8 (8.8)	30°	51	10
TKHRT 745 100	24 x M8 (8.8)	24 x M8 (8.8)	15°	101	15
TKHRT 745 150	24 x M10 (8.8)	24 x M10 (8.8)	15°	151	15
TKHRT 745 200	30 x M10 (8.8)	30 x M10 (8.8)	12°	201	20

Stator size TKHST	Stator fixing holes			Stator Length L1
	N° WS (min class)	N° OWS (min class)	a° (angular pitch)	
TKHST 745 50	18 x M6 (8.8)	18 x M6 (8.8)	20°	95
TKHST 745 100	24 x M8 (8.8)	24 x M8 (8.8)	15°	145
TKHST 745 150	30 x M8 (8.8)	30 x M8 (8.8)	12°	195
TKHST 745 200	30 x M10 (8.8)	30 x M10 (8.8)	12°	245

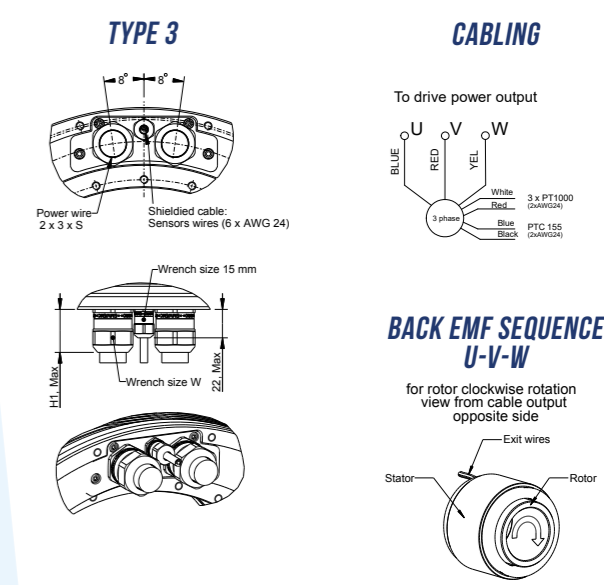
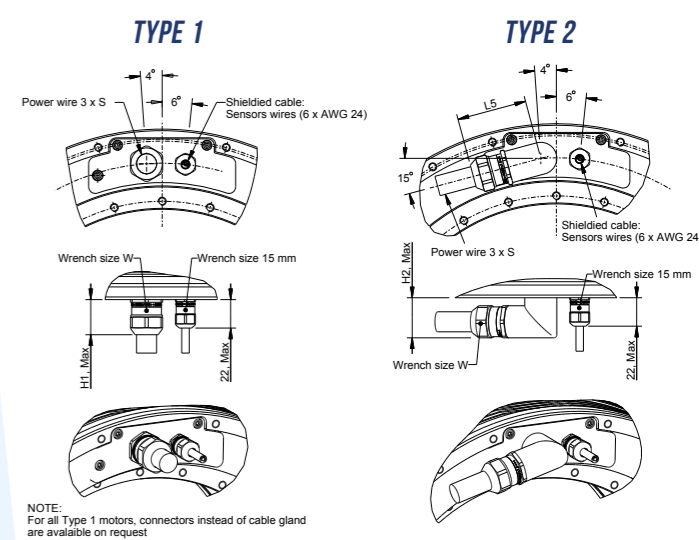

		050-49	050-61	050-122	100-49	100-98	100-122	150-73	150-147	200-98
Rated Torque	Nm	3150	3150	3170	6750	6780	6780	10350	10350	13980
Knee Speed	rpm	100	78	33	100	45	33	63	27	45
Rated Power	kW	33,0	25,7	11,0	70,7	32,0	23,4	68,3	29,3	65,9
Rated Current	A	71,1	56,7	28,5	153,3	76,9	61,5	157,1	78,5	159,4
Torque Constant	Nm/A	49,19	61,49	122,98	49,19	98,38	122,98	73,79	147,57	98,38
Peak Torque	Nm	5240	5250	5270	10550	10560	10560	15860	15860	21150
Peak Current	A	139,9	111,9	56,0	279,7	139,8	111,8	280,0	139,9	279,9
S6 Torque	① Nm	4575	4575	4575	9510	9510	9531	14512	14512	19404
Rated Torque at 0 rpm	Nm	2341	2341	2341	4995	4995	4995	7655	7655	10305
Max Continuous Speed	② rpm	160	160	160	160	160	160	160	160	160
Max Transient Speed	rpm	250	250	250	250	250	250	250	250	250
Motor Constant	Nm/√W	51,30	51,30	51,30	80,75	80,75	80,75	103,09	103,09	121,70
Number of Poles	-	140	140	140	140	140	140	140	140	140
Back EMF Constant	③ V*s	28,40	35,50	71,00	28,40	56,80	71,00	42,60	85,20	56,80
Thermal Time Constant	s	263,1	262,2	260,1	231,5	229,8	229,4	220,0	218,9	214,3
Min Coolant Flow	④ l/min	11,1	11,0	10,8	20,4	20,3	20,3	29,5	29,4	38,4
Motor Losses	⑤ kW	6,7	6,7	6,7	12,6	12,6	12,6	18,3	18,3	23,9
Rotor Inertia	kg*m ²	1,42	1,42	1,42	2,53	2,53	2,53	3,64	3,64	4,76
Rotor Mass	kg	8,1	8,1	8,1	16,0	16,0	16,0	24,0	24,0	31,9
Stator Mass	kg	59	59	59	99	99	99	137	137	176

TEST CONDITIONS

- ① 40% duty, 60s cycle
- ② for higher continuous speed refer to TKH high-speed version
- ③ at 20°C
- ④ Δt 10°C
- ⑤ at 1 rpm

*For higher speed solutions,
we have available TKH - HIGH SPEED version.
Please, contact our Technical Support Team
(support@phase.eu)
to find the best solution for your requirements.*



TORQUE SPEED DIAGRAM

TKH 825.050.49

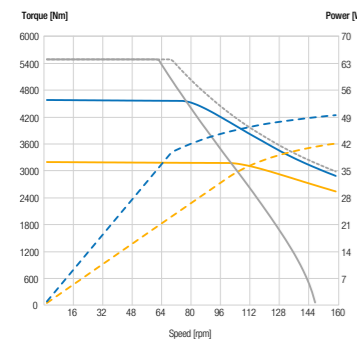

TKH 825.050.61

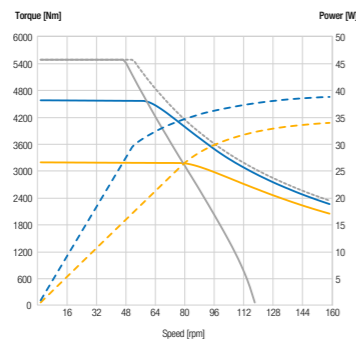

TKH 825.050.122

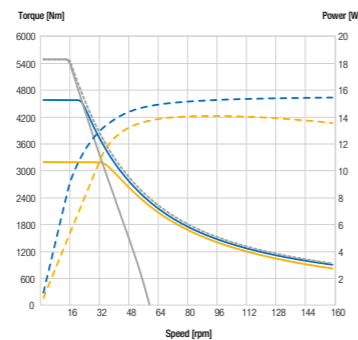

TKH 825.150.73

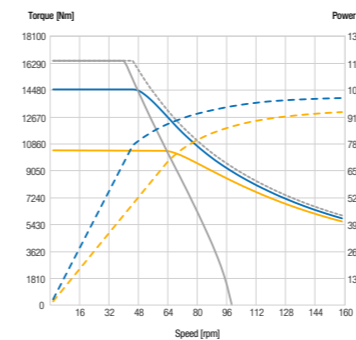

TKH 825.150.147

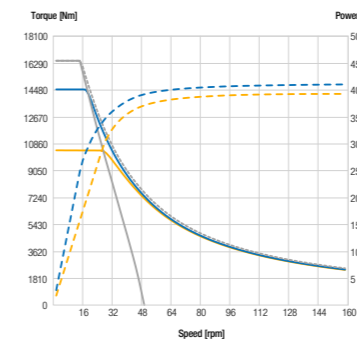

TKH 825.100.49

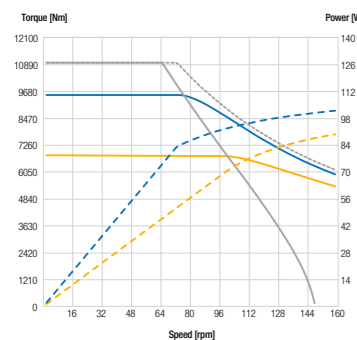

TKH 825.100.98

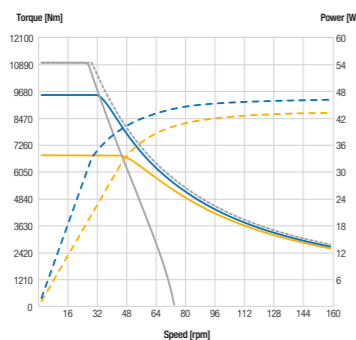

TKH 825.100.122

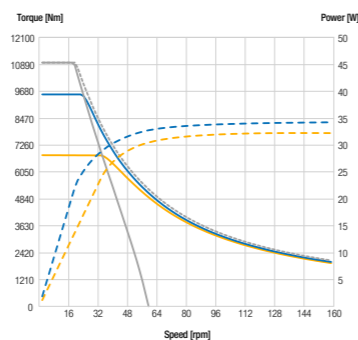

TKH 825.200.98

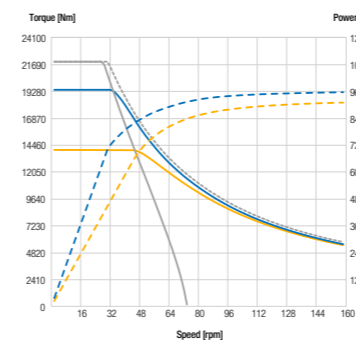

- S1 torque
- S6 torque, duty%
- Voltage saturation limit
- Saturation torque
- S1 power
- Peak power

We offer the flexibility to customize mechanical interfaces to suit your individual application needs, ensuring a seamless plug-and-play experience.

TECHNICAL DRAWING TKH 825

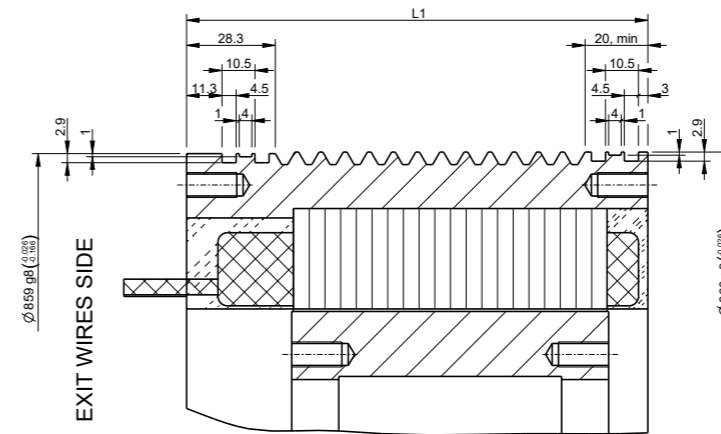
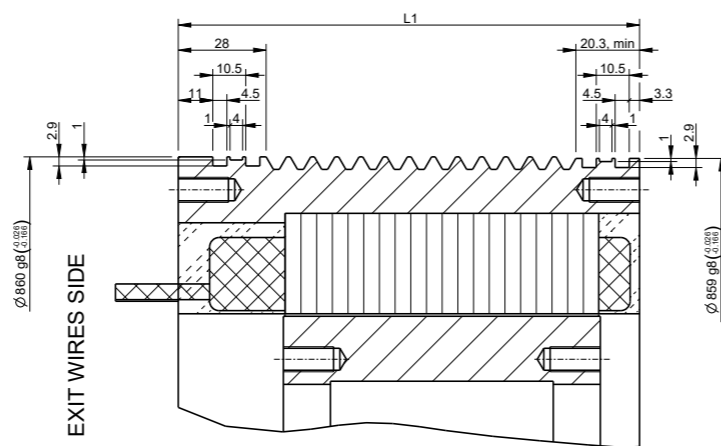
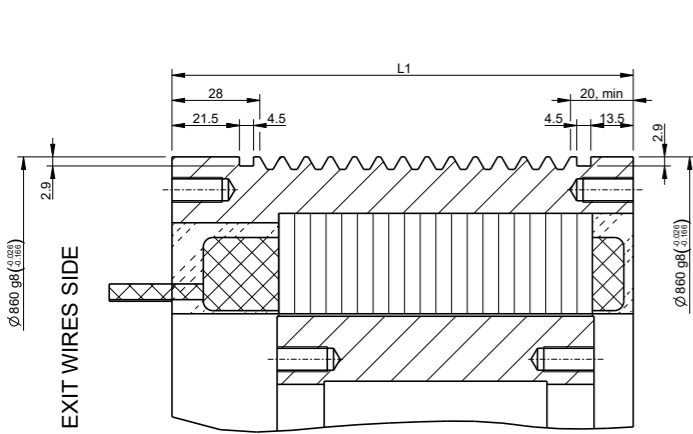
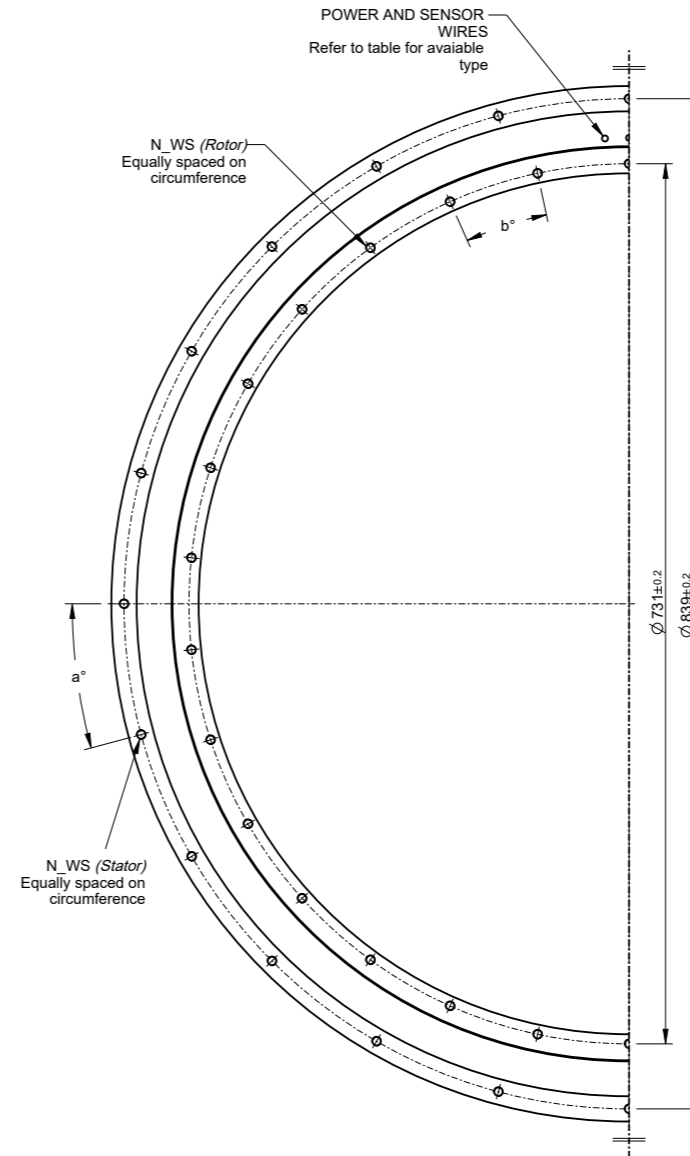
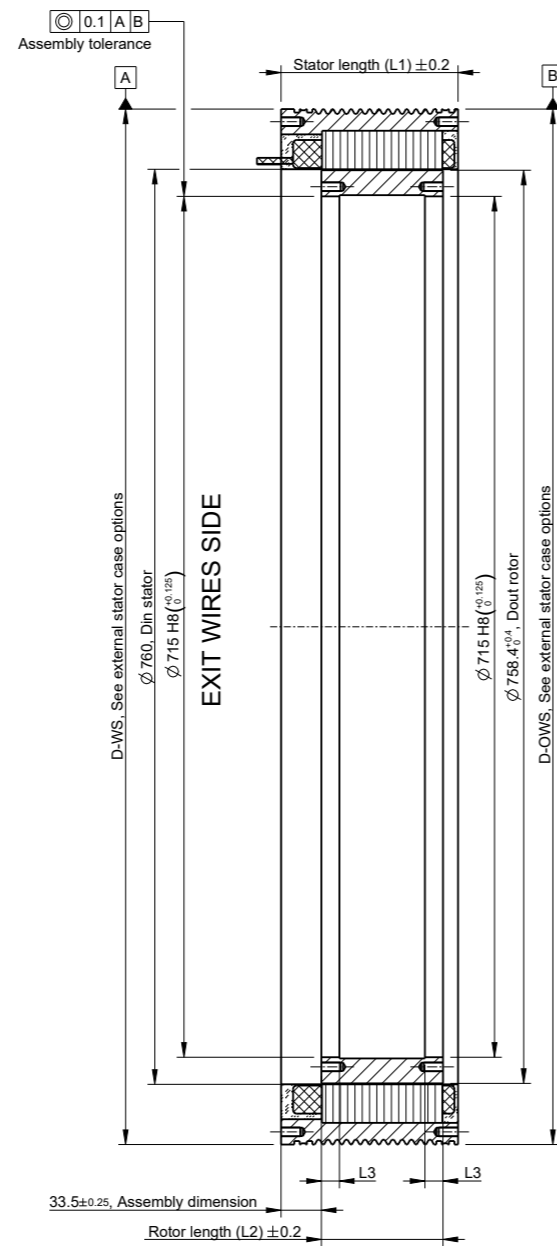
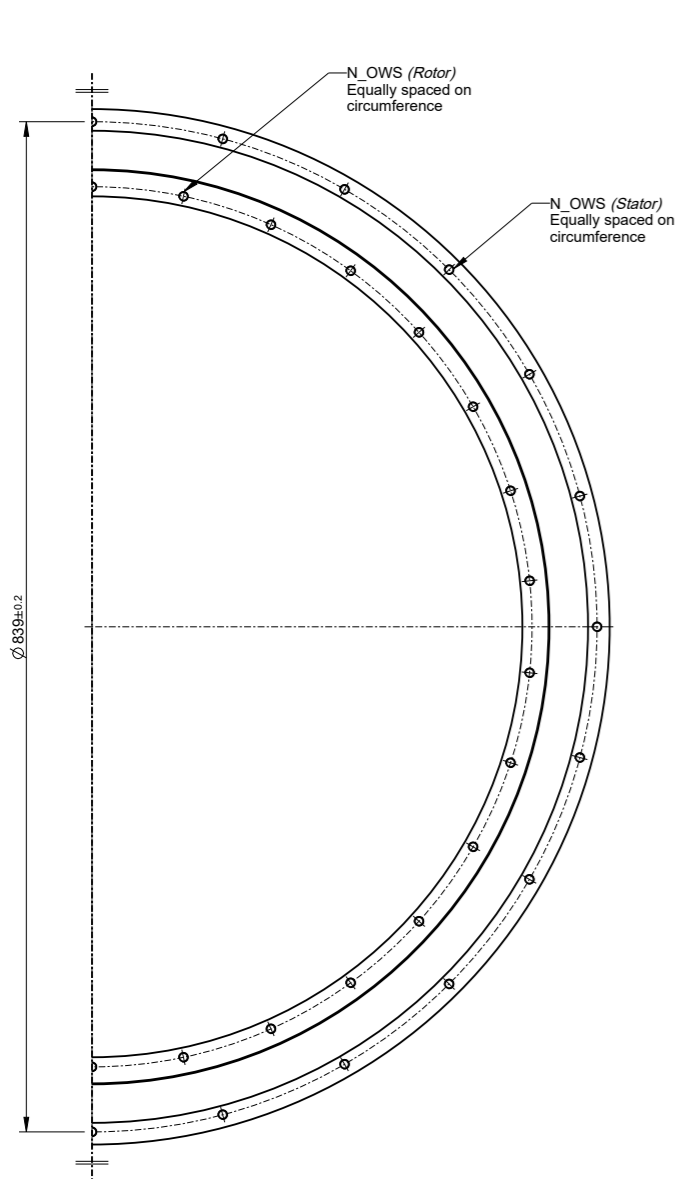

Rotor size TKHRT	Rotor fixing holes			Rotor dimensions	
	N_WS (min class)	N_OWS (min class)	b° (angular pitch)	L2 (Rotor length)	L3 (Centering length)
TKHRT 825 50	18 x M8 (8.8)	18 x M8 (8.8)	20°	51	10
TKHRT 825 100	30 x M8 (8.8)	30 x M8 (8.8)	12°	101	15
TKHRT 825 150	30 x M10 (8.8)	30 x M10 (8.8)	12°	151	15
TKHRT 825 200	24 x M12 (8.8)	24 x M12 (8.8)	15°	201	20

Stator size TKHST	Stator fixing holes			Stator Length L1
	N° WS (min class)	N° OWS (min class)	a° (angular pitch)	
TKHST 825 50	24 x M6 (8.8)	24 x M6 (8.8)	15°	97
TKHST 825 100	24 x M8 (8.8)	24 x M8 (8.8)	15°	147
TKHST 825 150	36 x M8 (8.8)	36 x M8 (8.8)	10°	197
TKHST 825 200	30 x M10 (8.8)	30 x M10 (8.8)	12°	247

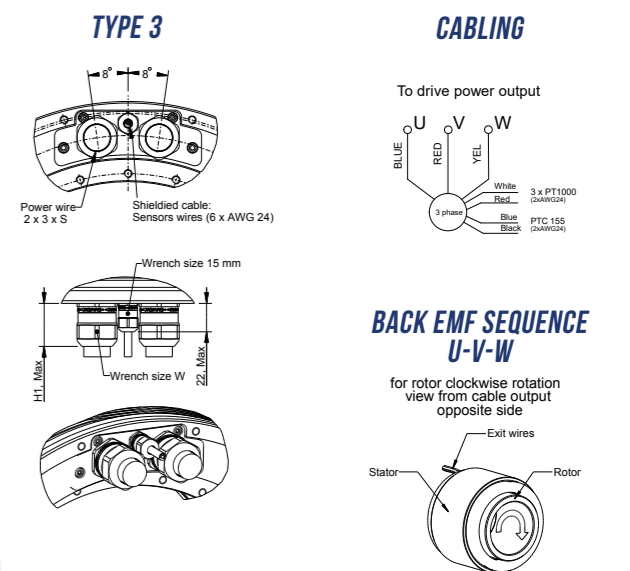
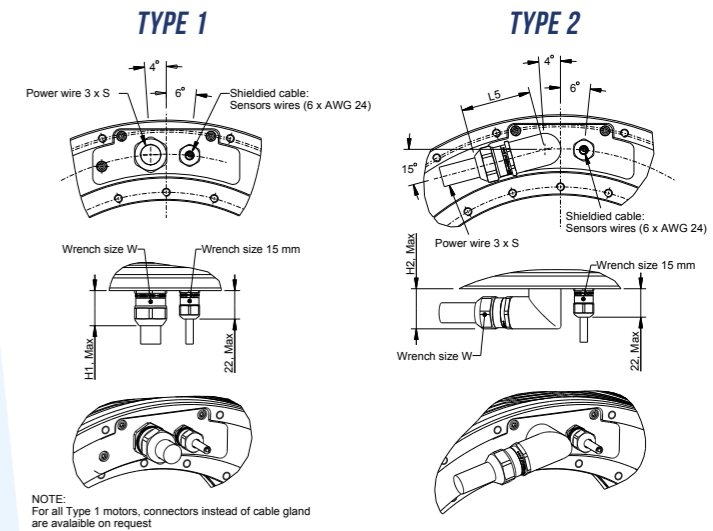

		050-151	100-54	150-82	200-109
Rated Torque	Nm	3810	8100	12440	16770
Knee Speed	rpm	26	90	58	40
Rated Power	kW	10,4	76,3	75,6	70,3
Rated Current	A	28,5	168,4	172,9	175,1
Torque Constant	Nm/A	151,14	54,96	82,44	109,92
Peak Torque	Nm	6390	12790	19220	25640
Peak Current	A	57,0	313,3	313,4	313,5
S6 Torque	① Nm	5484	11399	17365	23153
Rated Torque at 0 rpm	Nm	2808	5992	9183	12362
Max Continuous Speed	② rpm	150	150	150	150
Max Transient Speed	rpm	230	230	230	230
Motor Constant	Nm/√W	60,11	94,62	120,80	142,61
Number of Poles	-	154	154	154	154
Back EMF Constant	③ V*s	87,26	31,73	47,60	63,46
Thermal Time Constant	s	260,4	232,1	220,5	214,7
Min Coolant Flow	④ l/min	11,8	22,3	32,2	42,1
Motor Losses	⑤ kW	7,4	13,8	20,0	26,2
Rotor Inertia	kg*m ²	1,76	3,13	4,50	5,88
Rotor Mass	kg	8,2	16,3	24,4	32,5
Stator Mass	kg	64	109	151	193

TEST CONDITIONS

- ① 40% duty, 60s cycle
- ② for higher continuous speed refer to TKH high-speed version
- ③ at 20°C
- ④ Δt 10°C
- ⑤ at 1 rpm

*For higher speed solutions,
we have available TKH - HIGH SPEED version.
Please, contact our Technical Support Team
(support@phase.eu)
to find the best solution for your requirements.*



TORQUE SPEED DIAGRAM

TKH 895.050.151

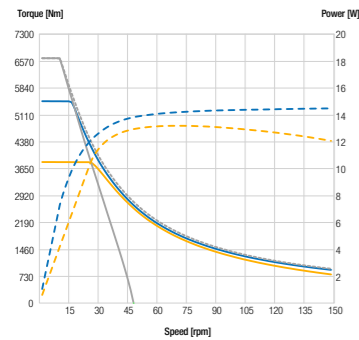

TKH 895.100.54

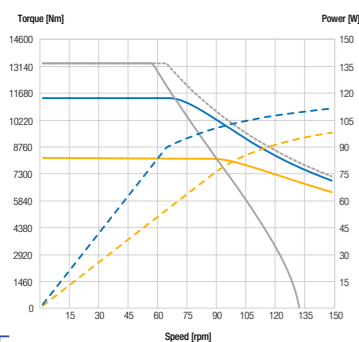

TKH 895.150.82

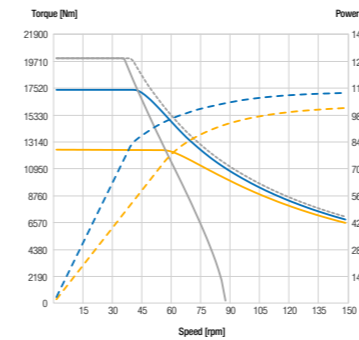

TKH 895.200.109

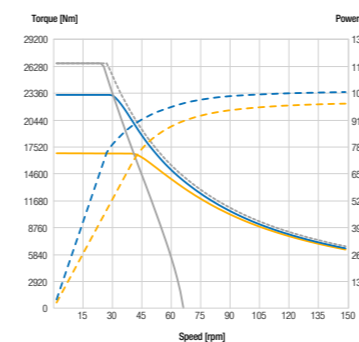

- S1 torque
- S6 torque, duty%
- Voltage saturation limit
- - - Saturation torque
- - - S1 power
- - - Peak power

We offer the flexibility to customize mechanical interfaces to suit your individual application needs, ensuring a seamless plug-and-play experience.

TECHNICAL DRAWING TKH 895

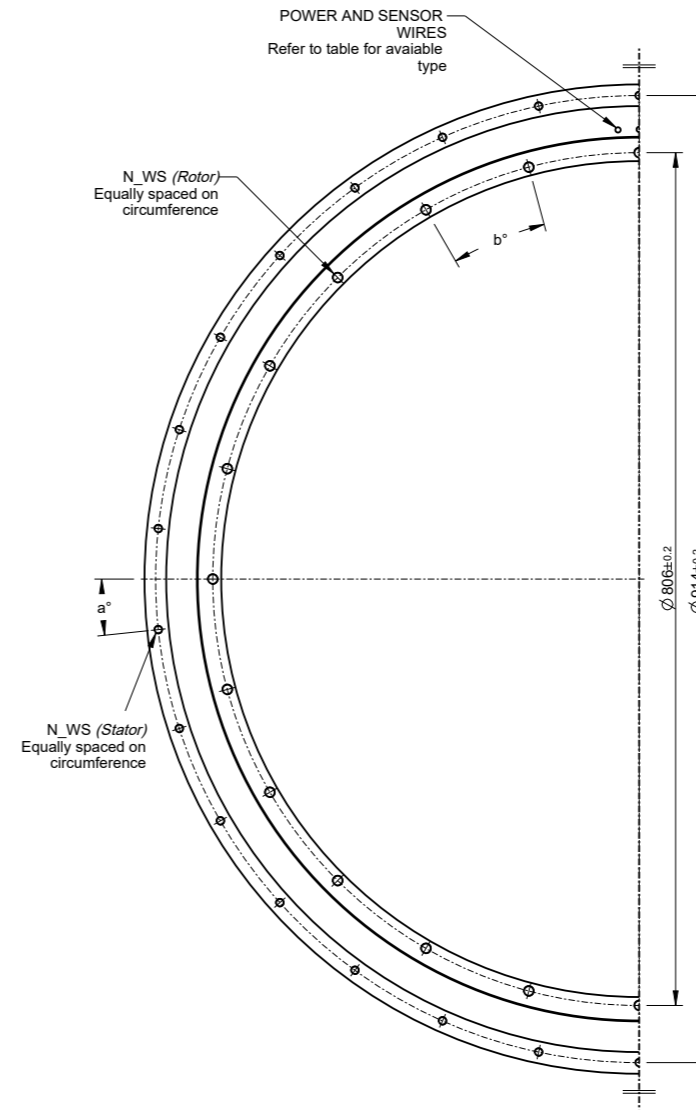
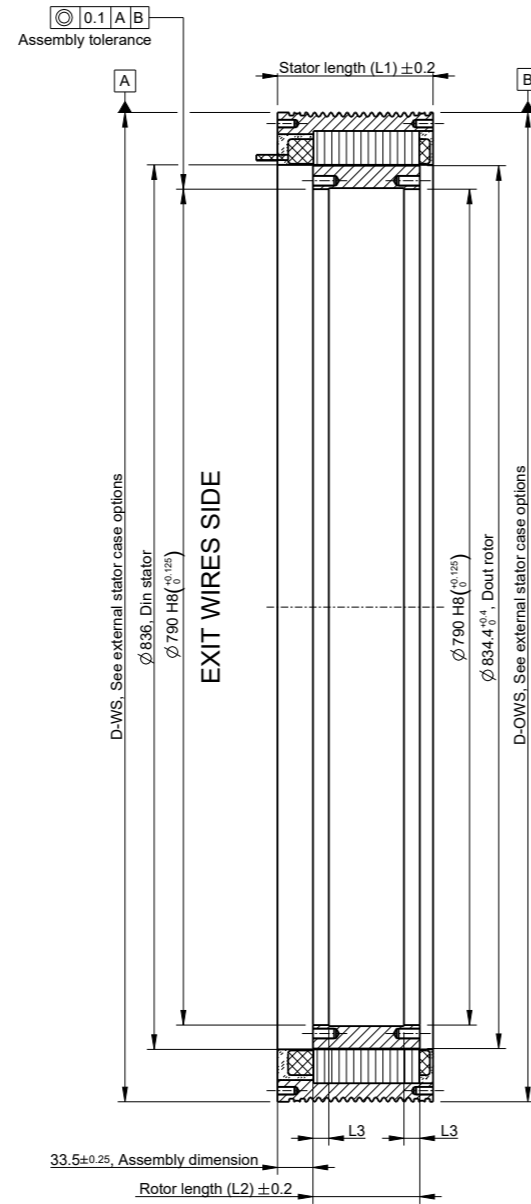
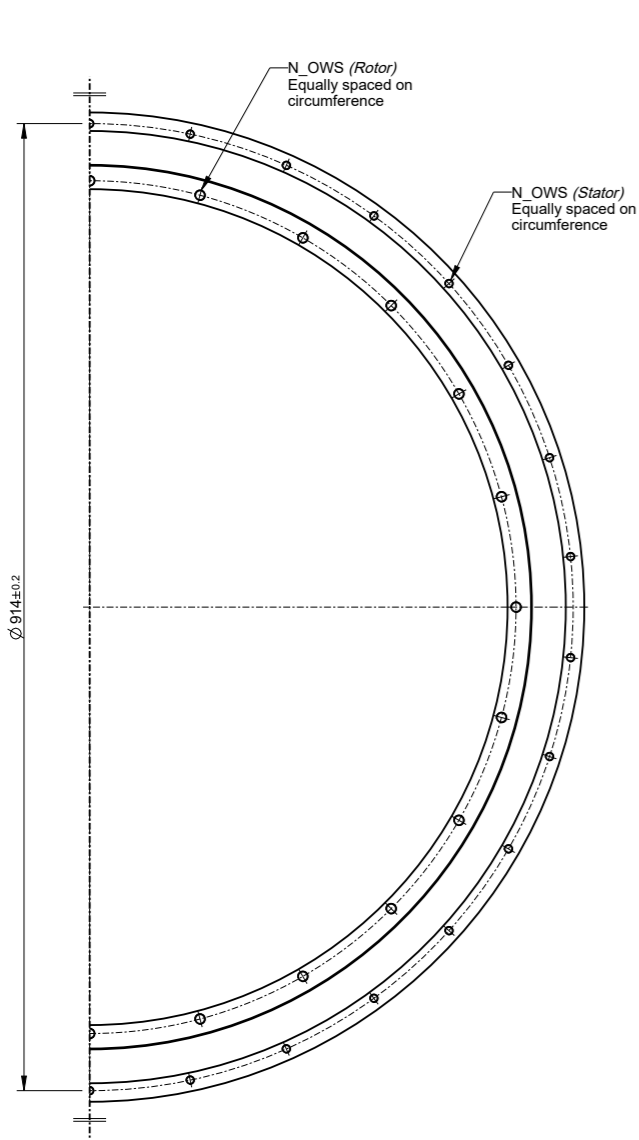

Rotor size TKHRT	Rotor fixing holes			Rotor dimensions	
	N_WS (min class)	N_OWS (min class)	b° (angular pitch)	L2 (Rotor length)	L3 (Centering length)
TKHRT 895 50	18 x M8 (8.8)	18 x M8 (8.8)	20°	51	10
TKHRT 895 100	24 x M10 (8.8)	24 x M10 (8.8)	15°	101	15
TKHRT 895 150	30 x M10 (8.8)	30 x M10 (8.8)	12°	151	15
TKHRT 895 200	30 x M12 (8.8)	30 x M12 (8.8)	12°	201	20

Stator size TKHST	Stator fixing holes			Stator Length L1
	N° WS (min class)	N° OWS (min class)	a° (angular pitch)	
TKHST 895 50	24 x M6 (8.8)	24 x M6 (8.8)	15°	90
TKHST 895 100	30 x M8 (8.8)	30 x M8 (8.8)	12°	147
TKHST 895 150	24 x M10 (8.8)	24 x M10 (8.8)	15°	247
TKHST 895 200	36 x M10 (8.8)	36 x M10 (8.8)	10°	247

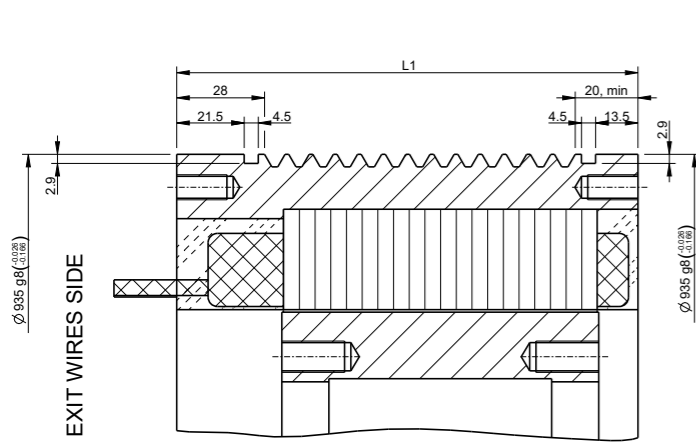

TYPE 1 - Same external centering diameter

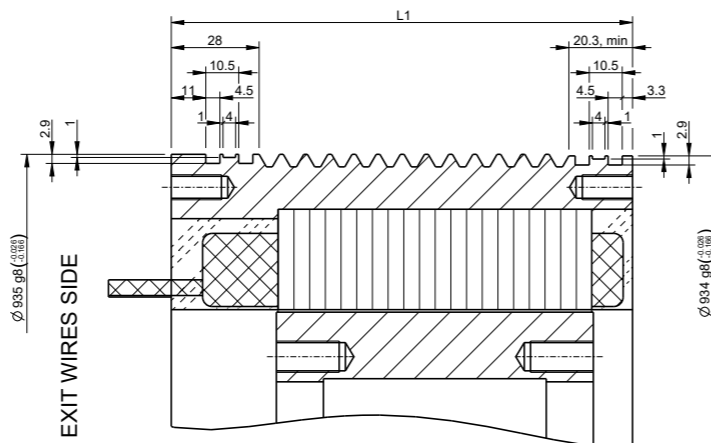

TYPE 2 - Bigger external centering on WS

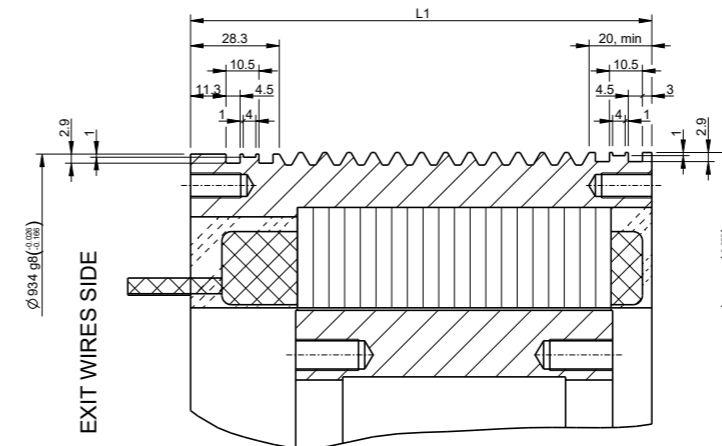

TYPE 3 - Bigger external centering on OWS

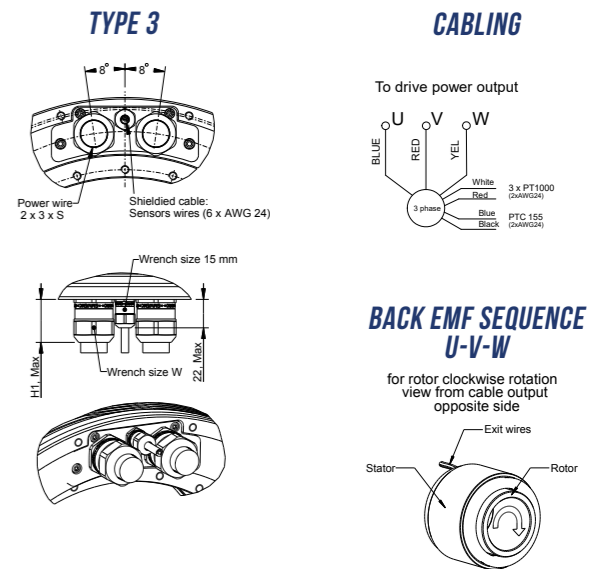
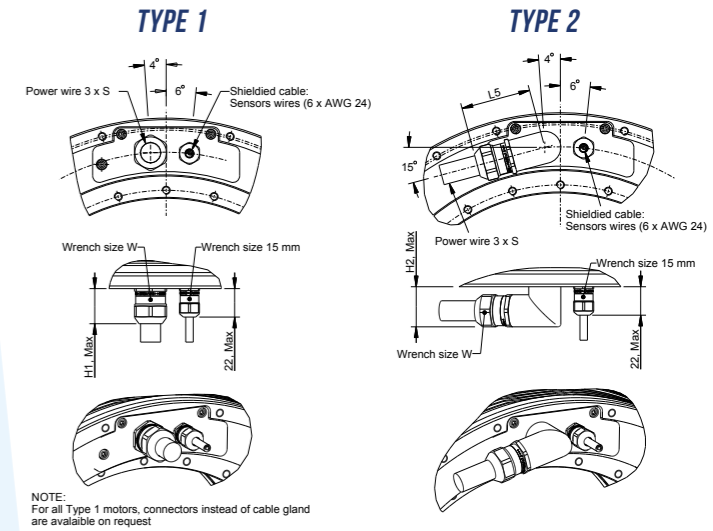

		050-44	050-59	050-88	050-118	100-59	100-88	100-118	100-177	150-88	150-132	150-177	200-118	200-177
Rated Torque	Nm	4480	4520	4540	4550	9670	9670	9670	9700	14900	14900	14900	20000	20000
Knee Speed	rpm	115	83	52	37	80	53	37	22	52	32	22	38	22
Rated Power	kW	54,0	39,3	24,7	17,6	81,0	53,7	37,5	22,4	81,1	49,9	34,3	79,6	46,1
Rated Current	A	112,3	84,9	56,7	42,6	182,9	121,8	91,3	61,0	188,5	125,6	94,1	189,8	126,5
Torque Constant	Nm/A	44,28	59,04	88,55	118,07	59,04	88,55	118,07	177,11	88,55	132,83	177,11	118,07	177,11
Peak Torque	Nm	7520	7540	7560	7570	15180	15200	15200	15200	22810	22820	22820	30400	30400
Peak Current	A	224,0	167,9	111,9	83,9	335,8	223,8	168,0	111,9	335,9	224,0	168,0	335,5	223,6
S6 Torque	① Nm	6528	6546	6528	6546	13668	13668	13668	13668	20860	20860	20860	27814	27814
Rated Torque at 0 rpm	Nm	3362	3362	3362	3362	7173	7173	7173	7173	10995	10995	10995	14803	14803
Max Continuous Speed	② rpm	140	140	140	140	140	140	140	140	140	140	140	140	140
Max Transient Speed	rpm	210	210	210	210	210	210	210	210	210	210	210	210	210
Motor Constant	Nm/√W	67,44	67,44	67,44	67,44	106,16	106,16	106,16	106,16	135,53	135,53	135,53	160,00	160,00
Number of Poles	-	168	168	168	168	168	168	168	168	168	168	168	168	168
Back EMF Constant	③ V*s	25,56	34,08	51,13	68,17	34,08	51,13	68,17	102,25	51,13	76,69	102,25	68,17	102,25
Thermal Time Constant	s	265,7	264,3	262,7	261,7	232,6	231,4	230,7	229,9	220,9	220,1	219,7	215,1	214,5
Min Coolant Flow	④ l/min	13,5	13,2	13,0	12,9	24,4	24,2	24,2	24,2	35,2	35,1	35,1	45,9	45,9
Motor Losses	⑤ kW	8,0	8,0	8,0	8,0	15,0	15,0	15,0	15,0	21,8	21,8	21,8	28,5	28,5
Rotor Inertia	kg*m ²	2,48	2,48	2,48	2,48	4,41	4,41	4,41	4,41	6,35	6,35	6,35	8,28	8,28
Rotor Mass	kg	9,7	9,7	9,7	9,7	19,3	19,3	19,3	19,3	28,9	28,9	28,9	38,4	38,4
Stator Mass	kg	72	72	72	72	118	118	118	118	164	164	164	210	210

TEST CONDITIONS

- ① 40% duty, 60s cycle
- ② for higher continuous speed refer to TKH high-speed version
- ③ at 20°C
- ④ Δt 10°C
- ⑤ at 1 rpm

*For higher speed solutions,
we have available TKH - HIGH SPEED version.
Please, contact our Technical Support Team
(support@phase.eu)
to find the best solution for your requirements.*



TORQUE SPEED DIAGRAM

TKH 975.050.44

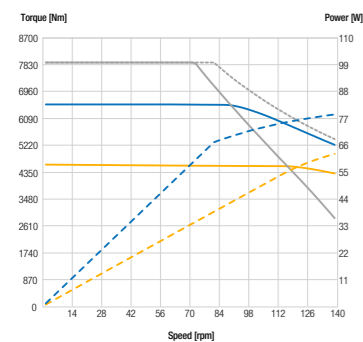

TKH 975.050.59

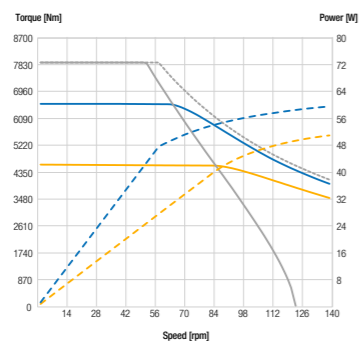

TKH 975.050.88

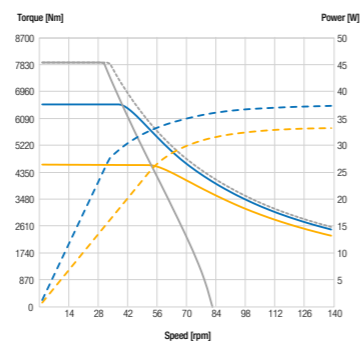

TKH 975.050.118

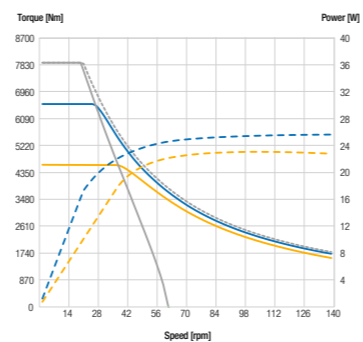

TKH 975.150.88

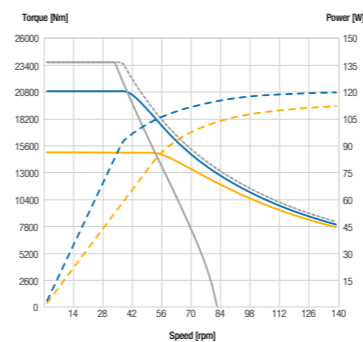

TKH 975.150.132

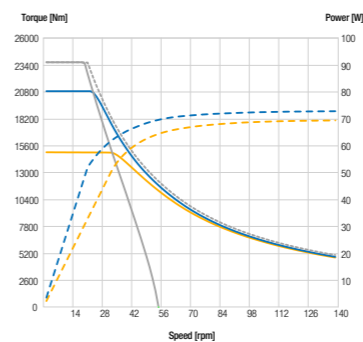

TKH 975.150.177

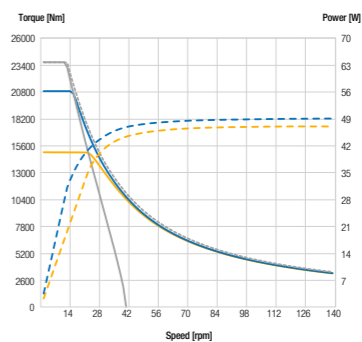

TKH 975.100.59

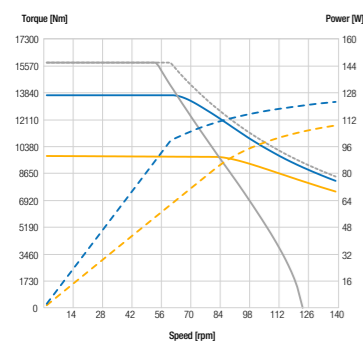

TKH 975.100.88

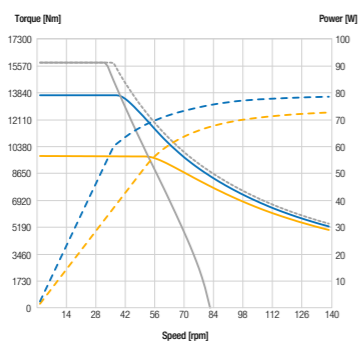

TKH 975.100.118

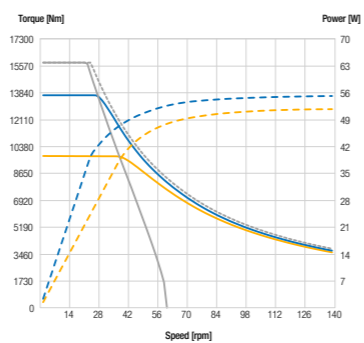

TKH 975.100.177

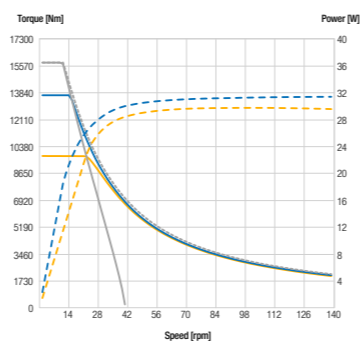

TKH 975.200.118

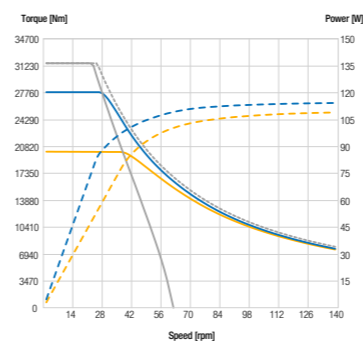

TKH 975.200.177

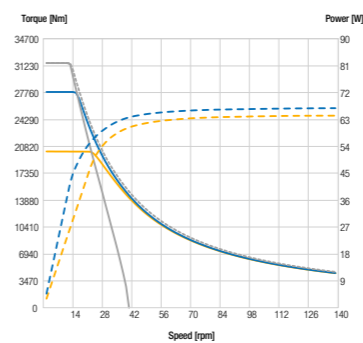

- S1 torque
- S6 torque, duty%
- Voltage saturation limit
- - - Saturation torque
- - - S1 power
- - - Peak power

We offer the flexibility to customize mechanical interfaces to suit your individual application needs, ensuring a seamless plug-and-play experience.

TECHNICAL DRAWING TKH 975

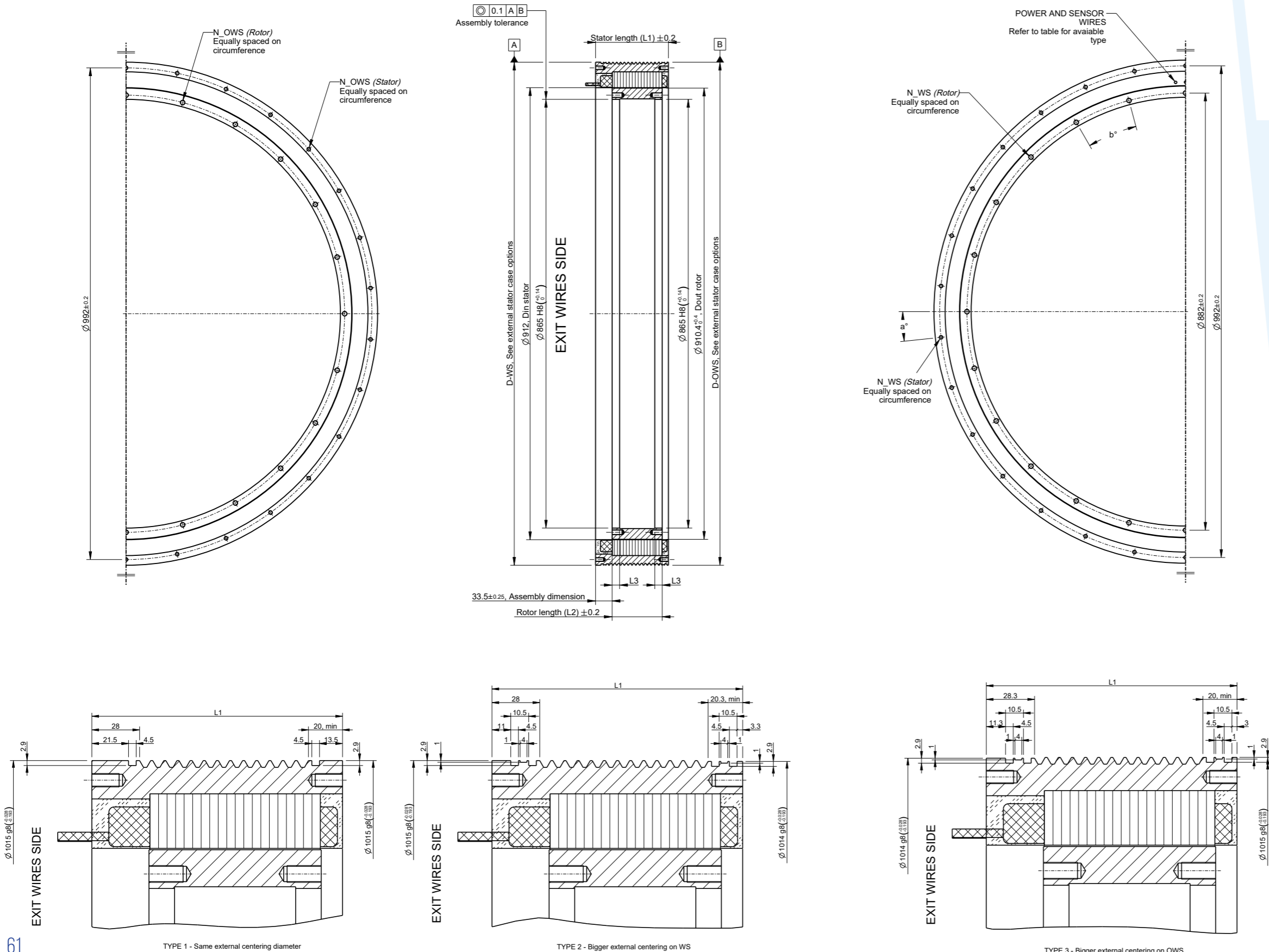

Rotor size TKHRT	Rotor fixing holes			Rotor dimensions	
	N_WS (min class)	N_OWS (min class)	b° (angular pitch)	L2 (Rotor length)	L3 (Centering length)
TKHRT 975 50	18 x M8 (8.8)	18 x M8 (8.8)	20°	51	10
TKHRT 975 100	24 x M10 (8.8)	24 x M10 (8.8)	15°	101	15
TKHRT 975 150	30 x M10 (8.8)	30 x M10 (8.8)	12°	151	15
TKHRT 975 200	30 x M12 (8.8)	30 x M12 (8.8)	12°	201	20

Stator size TKHST	Stator fixing holes			Stator Length L1
	N°_WS (min class)	N°_OWS (min class)	a° (angular pitch)	
TKHST 975 50	18 x M8 (8.8)	18 x M8 (8.8)	20°	97
TKHST 975 100	30 x M8 (8.8)	30 x M8 (8.8)	12°	147
TKHST 975 150	30 x M10 (8.8)	30 x M10 (8.8)	12°	197
TKHST 975 200	36 x M10 (8.8)	36 x M10 (8.8)	10°	247

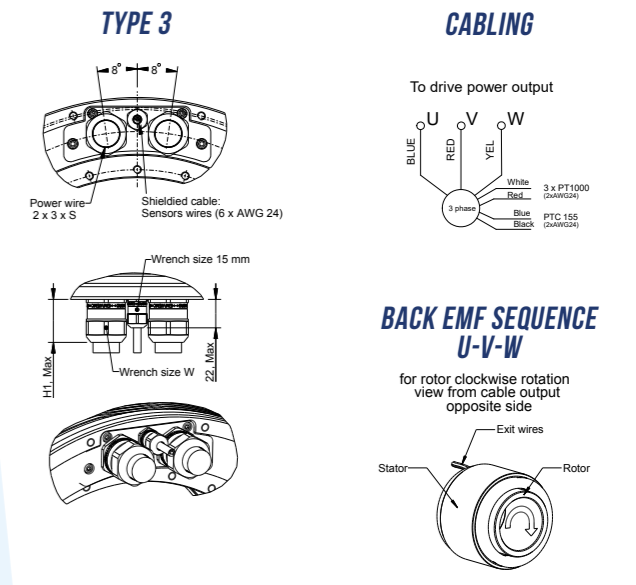
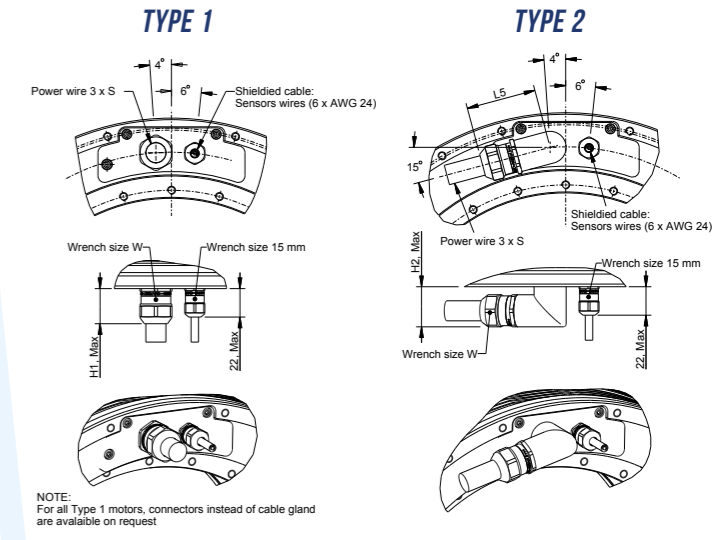

OUR WORLDWIDE EXPERTS' NETWORK AT YOUR SERVICE

Phase Motion Control engineering team cooperates with customers around the globe to solve technological challenges. To respond to diverse needs across motion control solutions, Phase Motion Control offers a wide range of expertise with a team of interdisciplinary electric, mechanical, servo and power conversion experts available worldwide.

Phase USA Inc.

In the heart of U.S.A (Chicago) to provide support and solutions in the United States.
sales@phaseusa.us

Phase Automation GmbH

The technical and commercial support in German-speaking countries.
office@phase-automation.at

Phase Automation Sarl

Technical and commercial support in French-speaking countries.
contact@phase-automation.com

PHASE ITALY HQ. Genoa

- The Italian Factory is the Main Manufacturing and R&D Plant.
 - Ongoing equipment upgrade
- New CNC manufacturing area, high density winding, vacuum potting facility, high accuracy balancing, multiple NC measuring. (160 Employees)

In Phase Motion Control, expertise is dedicated to providing comprehensive mechanical and electrical support. With over 100,000 torque motor units in operation worldwide, since 1994, we strive to always be at the forefront of innovation and shape the future together. For any support need, to reach out to us at the following contacts:

- support@phase.eu for technical support
- repair@phase.eu for failure analysis and repair activities
- customercare@phase.eu for any enquiry and customer assistance

We are committed to helping our customers achieve their goals and overcome their technological challenges with our comprehensive range of motion control solutions. Let us help you reach your objectives.

IN LINE WITH OUR STRATEGY OF CO-ENGINEERING ADVANCED SOLUTIONS, WE PROVIDE:

- Expertise and experience in many application fields, from automation and robotics, to NC machine tools and servo press, all the way to lifting, HVAC, flight simulation and motion systems;
- Electric mobility technology: from battery to drive to motors, for undersea, oversea, land and air propulsion;
- High power density, low mass advanced drives and actuators for avionics;
- Electrical and mechanical failure analysis, remedial actions;

